

# BEARING FRAME AND HOUSING

## CHALLENGE

### Prevent oil leaks from threaded assemblies

Drain plugs, oiler nipples, fittings, etc., all have air space between the threads and can weep oil out from the bearing housing. Constant pressure changes within the bearing housing can force these threaded assemblies to leak.

## SOLUTION

- › Seal threaded assemblies with LOCTITE® 567 Thread Sealant.
- › LOCTITE® 567 Thread Sealant is designed to cure only when enclosed in metal, such as in a threaded assembly.
- › Once cured, moisture and oil cannot penetrate this barrier as the pressure changes within the bearing housing.
- › The thread sealant prevents fittings from loosening, yet allows for easy disassembly with normal hand tools.

### Steps

1. Clean parts of contamination. If necessary, spray LOCTITE® 7649 Primer N onto threaded parts (male and female). Allow to dry.
2. Apply a band of LOCTITE® 567 Thread Sealant to male threads, starting one to two threads from end of fitting.
3. Assemble parts per OEM specifications.

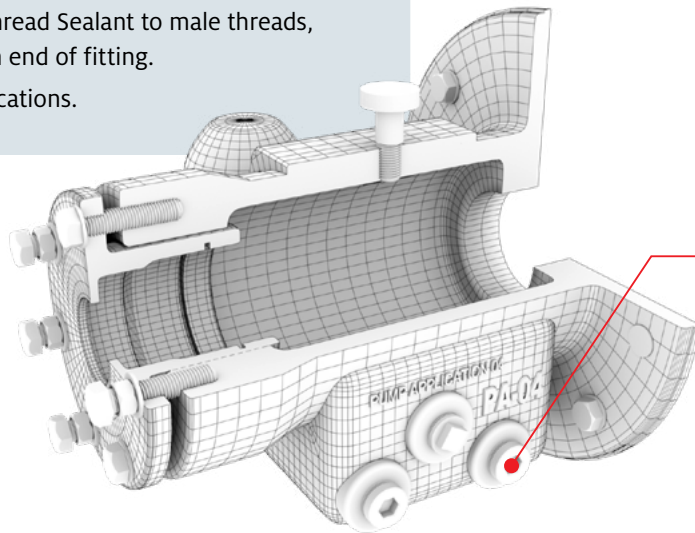

**LOCTITE® 567**  
Thread Sealant

## RESULTS

- › Less oil consumption, thereby reducing the risk of the pump running low on lubricant.
- › Elimination of the potential hazards and cleanup associated with oil leaks.
- › Elimination of seized fittings because moisture and air have been sealed out.
- › Elimination of rust and corrosion within the thread space.
- › Contaminants prevented from getting into the oil through the gaps in the threads.

**LOCTITE®**