

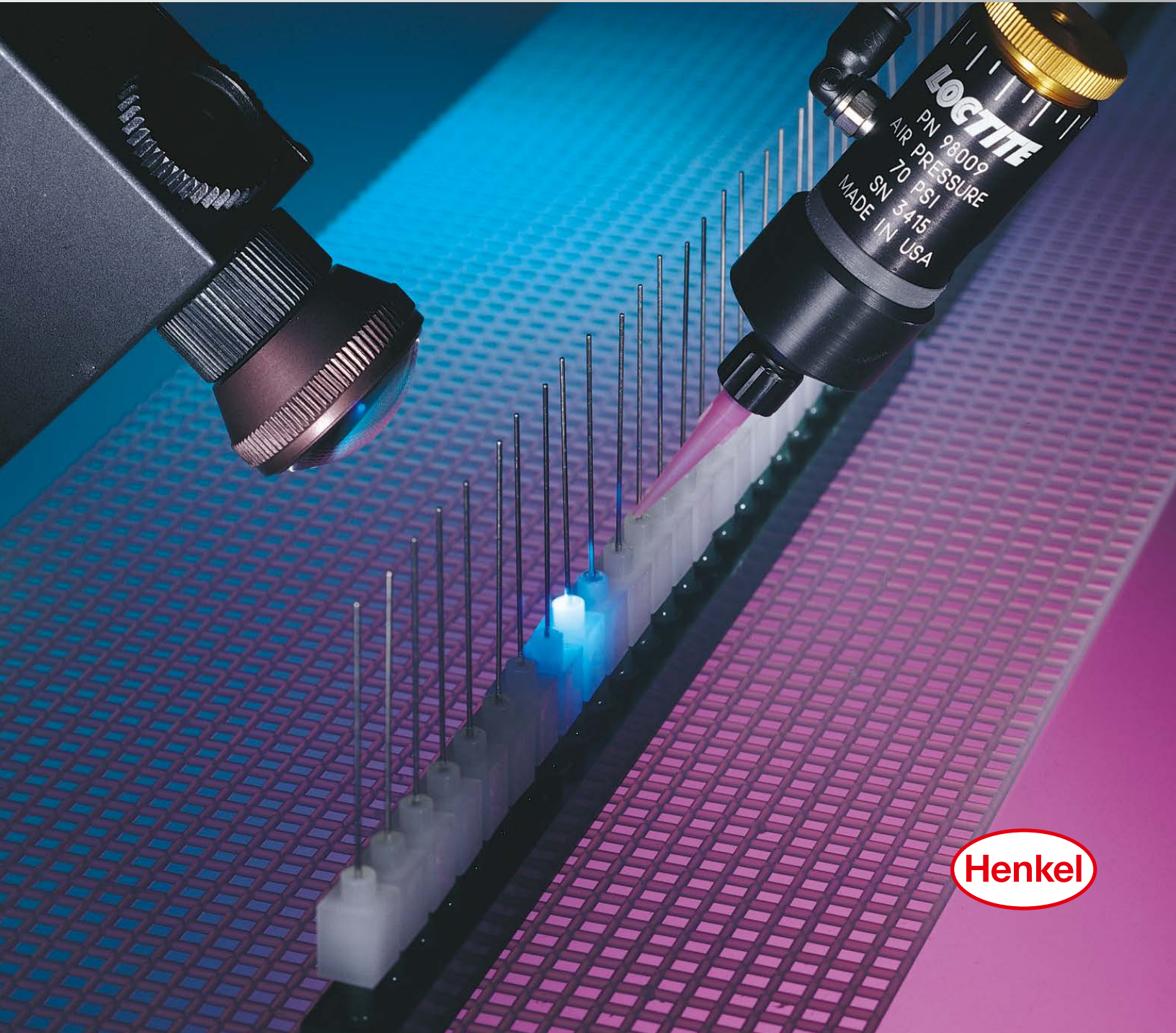

# Needle Bonding Design Guide



# Henkel Corporation

## A World of Resources

With a global network of engineering, product development and sales facilities operating in more than 80 countries, Henkel provides a world of resources to its partners. Henkel has a diversified and comprehensive line of adhesives, dispensing systems and curing systems.

### ENGINEERING SERVICES

From design recommendations to full production line implementation, the Henkel engineering department is an extension of your own. A staff of engineers with more than 150 combined years of experience is ready to assist with design recommendations, adhesive selection and qualification, and process guidance. With state-of-the-art engineering centers located around the world, Henkel is positioned to support the technical needs of our worldwide partners.

### BIOCOMPATIBILITY SCREENING

Medical device manufacturers around the world have specified LOCTITE® adhesives for more than three decades. We have a comprehensive ISO 10993 biocompatibility test program with periodic re-testing that allows medical device manufacturers to feel confident that the adhesives specified will meet even the most stringent compliance requirements. Certificates of compliance, formulation documentation, and triennial testing are key features of the *LOCTITE* medical device adhesive program.

### RESEARCH AND DEVELOPMENT

For nearly 60 years, Henkel has been committed to the development of innovative technologies and processes. We offer an immense Research, Development and Engineering operation devoted to adhesives. From the development of patented core technologies to the custom formulation of end-user specific adhesives and sealants, Henkel is positioned to serve as your adhesive development partner.

### TRAINING

A well-educated partner is a successful one. From in-plant training to advanced technology seminars, Henkel training programs ensure that the optimum design, the most suitable adhesive, and the most robust processes are available to device manufacturers around the globe. Beyond formal training programs, we offer a network of informational resources including our comprehensive website, [henkelna.com/medicaladhesives](http://henkelna.com/medicaladhesives), adhesive design guides, research data, and technical reports.

<b>Henkel Corporation: A World of Resources</b>	2
Engineering Services	2
Biocompatibility Screening	2
Research and Development	2
Training	2
<b>Overview</b>	3
The Issue	3
The Solution	3
<b>Needle Manufacturing Considerations</b>	4
Needle Design	4
Process Design	6

<b>Adhesive Selection</b>	7
Overview	7
Step 1: Select Adhesive Chemistries	8
Light Cure Acrylics	9
Light Cure Cyanoacrylates	10
One-Part Heat Cure Epoxies	11
Step 2: Select Adhesive Candidates	12
Viscosity and Flow Time Relationship	12
Occlusion and Flow Time Relationship	12
Fluorescence	13
Cure Speed	13

# Overview

## The Issue

Adhesives are universally used for bonding cannulae to hubs in needle assemblies. It is critical that this joint is well sealed to prevent fluids, such as blood or medicine, from leaking. It is also essential that the position of the cannula remains fixed. Since the adhesive joint has a profound and visible impact on the fitness-of-use of the needle assembly, needle designers often specify large safety factors on the adhesive joint, while their manufacturers operate with Six Sigma control limits. These stringent requirements cause the adhesive selection and qualification process to be lengthy and expensive.

The cannula to hub joint's unique geometry further complicates adhesive selection. The joint is small and cylindrical, typically joining a stainless-steel cannula to a plastic hub. Although many adhesive suppliers publish comprehensive technical data sheets for their products, this data typically reflects industry standard tests such as lap shear strength. Since industry standard tests are not representative of a real needle assembly, manufacturers cannot normally extrapolate published data to actual performance in a needle design.

Manufacturers with limited experience with a particular needle design must often select adhesives for qualification using limited information. This can result in expensive test programs if a large number of adhesive candidates is evaluated. On the other hand, an inferior adhesive may be selected if a small number of adhesive candidates is used.

## The Solution

This guide is designed to provide a step-by-step process for quickly and effectively selecting adhesives that are well suited for a specific needle design. The process is supported by a comprehensive summary of adhesive selection and needle performance data (See **Appendix 1 and 2**).

### THE FOLLOWING TOPICS ARE PRESENTED IN THIS GUIDE:

#### NEEDLE MANUFACTURING CONSIDERATIONS

Design variables that affect needle pull strength, key considerations for the manufacturing process, and adhesive dispensing and curing equipment.

#### ADHESIVE SELECTION

Step-by-step instructions on how to select adhesives for a specific needle application, including detailed descriptions of each of the most commonly used adhesive types.

#### TEST METHODOLOGY

A comprehensive discussion on the experimental test matrix development and the needle pull strength testing procedure.

Step 3: Review Needle Pull Strength Data to	
Finalize Candidates . . . . .	14
Needle Pull Strength. . . . .	14
Effect of Annular Rings . . . . .	14
Sterilization Resistance . . . . .	15
Thermal Stability. . . . .	15
Effect of $T_g$ on Accelerated Aging . . . . .	15
Step 4: Screen Adhesive Candidates by Building	
Prototypes . . . . .	16
Step 5: Qualify Lead Candidates Fully . . . . .	16

<b>Test Methodology</b> . . . . .	17
Determining the Experimental Test Matrix. . . . .	17
Determining the Accelerated Aging Conditions . . . . .	18
Determining the Test Method . . . . .	19
Experimental Procedure. . . . .	20
<b>Equipment</b> . . . . .	21
<b>Appendix 1: LOCTITE Adhesive Selector Chart</b> . . . . .	22
<b>Appendix 2: Needle Pull Strength Data</b> . . . . .	24
<b>Product Ordering Information</b> . . . . .	26
<b>Technical Support</b> . . . . .	27

# Needle Manufacturing Considerations

## Needle Design

The cutaway drawing below illustrates the key design variables that will affect the performance of a bonded needle joint. Each variable is discussed in detail and the LOCTITE® needle test specimens are described.

### Hub Material

Hubs can be composed of a variety of plastic substrates. Among those commonly used are ABS, acrylic, polycarbonate (PC), polyethylene (PE), polypropylene (PP), polysulfone (PS), and polyurethane (PU).

**LOCTITE test specimens are ABS, acrylic, PC, PE, PP, PS, and PU.**

### Core and Engagement Length

The core is located beneath the well, where the inner diameter of the hub decreases to a slight slip fit with the cannula. The length of the core is typically called the engagement length. As engagement length increases, needle pull strength increases until the strength of the adhesive joint exceeds that of the hub or cannula. When high viscosity adhesives are used, the adhesive often will not fill the entire engagement length.

**LOCTITE test specimens have a 0.16" engagement length.**

### Well Design

The well is used to promote the flow of adhesive into the bondline and to align the adhesive dispense tip with the cannula to the hub joint. As well diameter increases, the adhesive normally flows more rapidly into the well. The bond area also increases, making the adhesive less likely to fail to the hub. As well depth increases, the pull strength also increases.

**LOCTITE test specimens have a 0.060" diameter by 0.080" deep well.**

### Cannula Gauge Size

Cannula gauge size significantly affects both pull strength and failure mode. As gauge size increases, the circumference of the cannula decreases, reducing the surface area of the joint and subsequently decreasing needle pull strength. When bonding larger gauge sizes such as 27-gauge, adhesives commonly fail to the cannula and remain in the well. When bonding small gauge sizes such as 22-gauge, the adhesive often fails to the hub and remains on the cannula.

**LOCTITE test specimens use 22- and 27-gauge cannulae.**

### Annular Rings

With difficult-to-bond plastics, the adhesive may release from the hub at pull forces below design requirements. To increase the pull strength, annular rings can be designed into the hub by molding ringed recesses in the inner diameter of the core and/or well. When the adhesive flows into the recessed rings and cures, it bonds to the cannula and is mechanically held in the rings. The typical depth for annular rings is 0.005" to 0.008".

**LOCTITE test specimens do not have annular rings.**

### Diametrical Gap

The diametrical gap is the difference between the inner diameter of the hub and the outer diameter of the cannula. A 0.002" diametrical gap is very common. As the diametrical gap decreases, the adhesive more slowly fills the annular area in the core. As the diametrical gap increases, the adhesive is more likely to migrate out of the back of the hub and pull strength may decrease. A diametrical gap of greater than 0.002" is uncommon unless the designer intends to use multiple gauge cannulae in one hub. In that scenario, diametrical gaps of 0.005" to 0.010" have been used.

**LOCTITE test specimens have a 0.002" diametrical gap for both 22- and 27-gauge assemblies.**

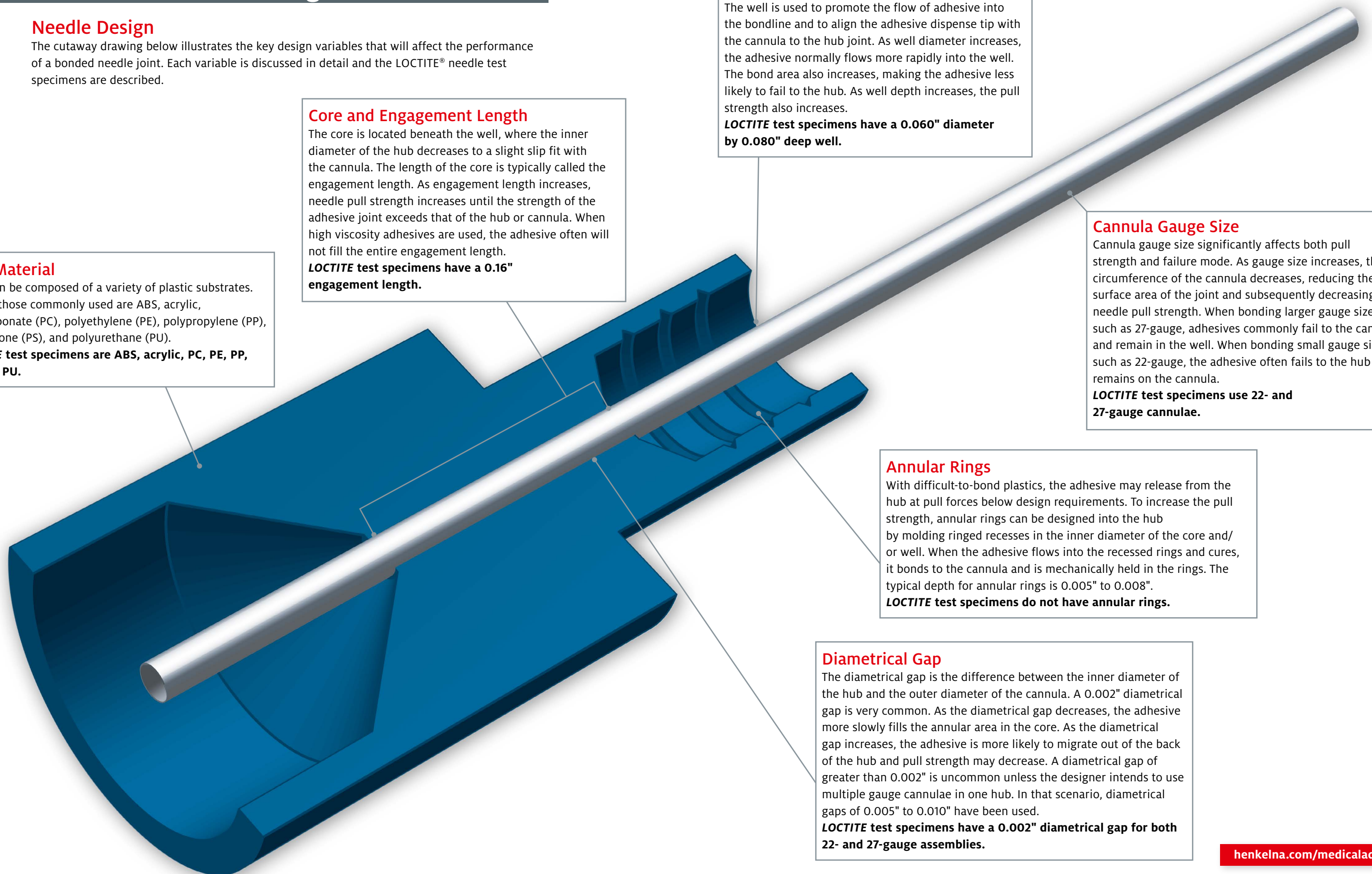

# Needle Manufacturing Considerations

## Process Design

The process schematic below illustrates the key steps in a needle bonding manufacturing process. Each process step and its impact on the performance of the needle assembly are discussed.

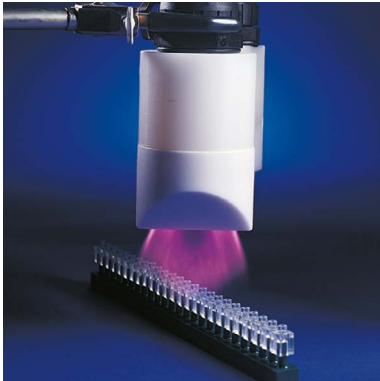

### SURFACE TREATMENT

Needles are commonly molded in polyolefins such as polyethylene (PE) and polypropylene (PP) due to their low cost and versatile properties. Since PE and PP are difficult-to-bond plastics, it is common to treat the hub before assembly to increase the pull strength.

Corona treatment is popular in needle assembly lines because it is an effective, in-line process. In a corona discharge process, the plastic is exposed to a corona discharge, usually in the presence of air and at atmospheric pressure. This roughens the surface and increases the surface energy of the plastic.

Plasma treatment is a batch operation by which the plastic is bombarded with ions of a gas at low pressure. Since this is a batch process, it is commonly used in laboratories. Experience indicates that the magnitude of the effect of plasma and corona treatment is generally similar.

### DISPENSE PROCESS TYPE

Needle manufacturers may dispense adhesive on the cannula before it is inserted in the hub or into the well after the cannula is inserted in the hub. For pre-assembly dispensing, a high viscosity adhesive must be used to hold the adhesive on the cannula. A typical viscosity range for pre-assembly dispensing is 3,000 to 30,000 cP. The pre-assembly dispensing process has the advantage of ensuring full adhesive coverage with minimal flow times via the needle insertion tip.

Alternatively, manufacturers may dispense the adhesive after the cannula has been assembled with the hub. This post-assembly dispensing process requires that a low viscosity adhesive be used, typically 20 to 3,000 cP. The lower the viscosity, the faster the adhesive will achieve full coverage of the joint.



### ADHESIVES AND EQUIPMENT

The LOCTITE® AssureCure™ system is a revolutionary technology that combines adhesive, a detection system and software to provide a quantifiable confirmation of cure level for light cure acrylic adhesives. The operation is easily integrated into existing production equipment, lines immediately following the light curing system. For more details on equipment, see p. 21 or visit [equipment.loctite.com](http://equipment.loctite.com).

#### Features and Benefits

Quantifiable Degree of Cure of Light Cure Adhesives

- Confirm cure
- Reduce in-process QC testing
- Reduce scrapped parts and resources
- Increase production speeds

AssureCure® Small System Size

- Easy fit into existing production lines
- Minimal space required

Connection to Existing PLCs

- Allows for go/no-go decision
- Data recording

ISO 10993 Biocompatible Adhesives

- Suitable for disposable medical device assembly

Fluorescent in Uncured and Cured State

- Confirmation of adhesive presence and location on parts



## FLOW (DWELL) TIME

When the adhesive is dispensed after the cannula and hub are assembled, some time will be required for the adhesive to flow into the well and core. In general, the lower the viscosity of the adhesive, the faster it will achieve full coverage. For example, the time to fill the well may increase from 5 seconds at 100 cP to 40 seconds at 9,000 cP.

The required flow time to fill the core is longer since a much smaller gap exists as compared to the well. In fact, with higher viscosity adhesives, it is common for the adhesive not to fully fill the core. A typical time to fill the core is 20 seconds at 100 cP. This can increase to 3 minutes at 6,000 cP.

A flow time is not required if the adhesive is dispensed onto the cannula, then inserted into the hub. In this process, the adhesive is forced into the well and core during the needle insertion step.

## CURE METHOD

The two most common cure methods for high volume production are:

- Light curing
- Heat curing

Light curing processes essentially eliminate work in process. A typical cure time is 6 to 20 seconds. The primary limitation is that light must reach the bondline, although light cure cyanoacrylates do have a rapid secondary cure.

Heat cure processes generally have a 15- to 45-minute cure time. This increases the time to manufacture and work in process when compared to the light cure process. The cure temperature can also limit the types of plastics that can be used for the needle hub.

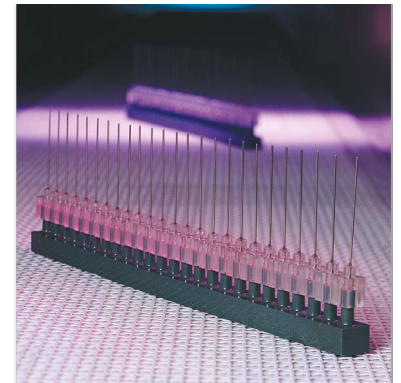

# Adhesive Selection

## Overview

This guide is designed to assist needle designers and manufacturers decrease time to market and qualification costs by assisting in the selection of adhesives that will meet or exceed their process and design requirements with minimal research and development.

## The Following Process Is Recommended:

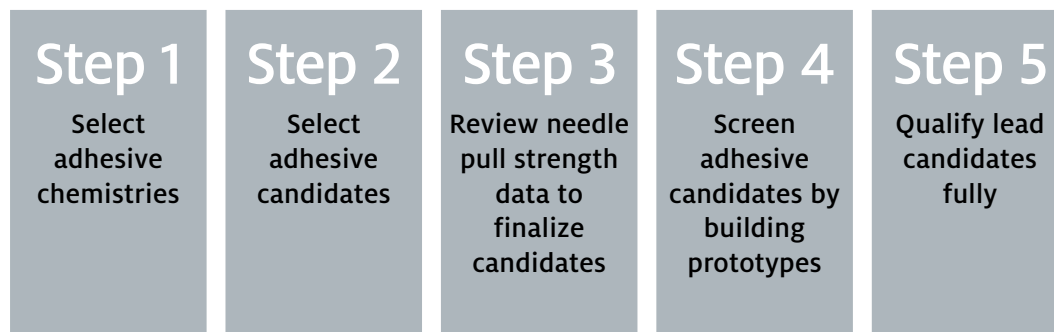

## Step

### Select Adhesive Chemistries

The three most commonly used adhesive chemistries for needle manufacturing are:

- Light Cure Acrylics
- Light Cure Cyanoacrylates
- One-Part Heat Cure Epoxies

Henkel has developed products in all three chemistries that are ISO 10993 qualified, have high pull strengths and fast cure times, and are highly fluorescent for automated in-line inspection. **Table 1** compares and contrasts the benefits and limitations of these three adhesive types.

Other adhesive chemistries also used for needle bonding include cyanoacrylates and two-part epoxies. These adhesives are normally used for low volume manufacturing operations that utilize manual assembly work cells. Although they are not discussed in this guide, questions regarding these adhesive technologies may be directed to 1-800-LOCTITE (562-8483).

TABLE 1: COMPARISON OF ADHESIVE CHEMISTRIES		
ADHESIVE CHEMISTRY	BENEFITS	CONSIDERATIONS
LIGHT CURE ACRYLICS	<ul style="list-style-type: none"> <li>• Fast cure – 6 to 20 seconds under a high intensity light</li> <li>• Wide range of physical properties available</li> <li>• Low viscosity (100 cP) provides fast flow when post-applying to assembled needle and cannula</li> <li>• Thermoset resins have good thermal and chemical resistance</li> </ul>	<ul style="list-style-type: none"> <li>• Will not cure in shadowed areas</li> <li>• Surface cure is inhibited by oxygen; the adhesive can remain tacky if a high intensity light source is not used</li> </ul>
LIGHT CURE CYANOACRYLATES	<ul style="list-style-type: none"> <li>• Fastest cure – 3 to 6 seconds with a low intensity light source</li> <li>• Fastest surface cure of &lt; 5 seconds with a low intensity light source</li> <li>• Cures rapidly in shadowed areas via cyanoacrylate cure mechanism</li> <li>• Wicking viscosity available (20 cP) that provides the fastest flow when post-applied</li> </ul>	<ul style="list-style-type: none"> <li>• Highest volumetric cost</li> <li>• Maximum viscosity of 900 cP mandates post-applying to assembled needle and cannula</li> <li>• If there are shadowed areas, blooming can compromise the aesthetics of the device</li> <li>• Lowest relative fluorescence</li> <li>• Thermoplastics have the lowest thermal and chemical resistance</li> <li>• Not recommended for use on glass</li> </ul>
ONE-PART HEAT CURE EPOXIES	<ul style="list-style-type: none"> <li>• Lowest volumetric cost</li> <li>• Highest relative fluorescence</li> <li>• All shadowed areas cure during heat cure process</li> <li>• Highly crosslinked thermosets provide the best thermal and chemical resistance</li> </ul>	<ul style="list-style-type: none"> <li>• Slowest cure – 15 to 45 minutes at 100°C to 150°C</li> <li>• Low viscosities (less than 5,000 cP) are not available; however, the viscosity drop during heat cure allows for good coverage when post-applying adhesive to an assembled needle</li> </ul>

## Light Cure Acrylics

### ADVANTAGES

- One-part
- Solvent-free
- Cure-on-demand
- Clear adhesive joints
- Rapid fixture and complete cure
- Good gap filling
- Wide range of physical properties
- Wide range of viscosities
- Good environmental resistance
- Dispensing is easily automated

### CONSIDERATIONS

- Light must reach the bondline
- Oxygen can inhibit surface cure
- Equipment expense for light source



### GENERAL DESCRIPTION

Light curing acrylic adhesives are one-part, solvent-free liquids with viscosities ranging from 50 cP to thixotropic gels. Upon exposure to light of the proper intensity and spectral output, these adhesives cure rapidly to form thermoset polymers with excellent adhesion to a wide variety of substrates.

Cure times are dependent on many parameters; however, 6- to 20-second cures are typical and cure depths in excess of 0.5" are possible. Various light curing acrylic formulations are available, and vary from very rigid plastic materials to soft, flexible elastomers when cured.

Light curing acrylic adhesives cure rapidly on demand, minimizing work-in-process and offering virtually unlimited repositioning time. In addition, the wide range of viscosities available facilitates the selection of a product ideally suited for automated dispensing.

### CHEMISTRY

Light curing acrylic adhesives are a blend of monomers, oligomers and polymers to which a photoinitiator is added. Upon exposure to light of the proper intensity and spectral output, the photoinitiator decomposes to yield free radicals. The free radicals then initiate polymerization of the adhesive through the acrylate groups to yield a thermoset polymer.

When the adhesive is cured in contact with air, the free radicals created by the decomposition of the photoinitiator can be scavenged by oxygen prior to cure. This can lead to incomplete polymerization of the adhesive at the adhesive/oxygen interface, yielding a tacky surface. To minimize the possibility of a tacky surface, irradiance can be increased, spectral output of the light source can be matched to the absorbance spectrum of the photoinitiator, and/or the adhesive can be covered with a nitrogen blanket during cure.



## Light Cure Cyanoacrylates

### ADVANTAGES

- One-part
- Solvent-free
- Rapid fixture and cure with low intensity light exposure
- Rapid room temperature fixture
- Cure in shadowed areas
- Not inhibited by oxygen
- Excellent adhesion to many substrates
- Superior bond strength in shear and tensile modes
- Primers available for polyolefins and difficult-to-bond plastics
- Wicking grade available

### CONSIDERATIONS

- Poor peel strength
- Limited gap cure in areas shielded from light (< 0.010")
- Poor durability on glass
- Low temperature resistance (maximum 82°C)
- Bonds skin rapidly



### GENERAL DESCRIPTION

Light curing cyanoacrylate adhesives are one-part, solvent-free materials available in two viscosity variations, 20 and 900 cP. Upon exposure to low intensity light, these adhesives cure rapidly to form thermoplastic polymers with superior adhesion to a wide variety of substrates. Adhesive contained in areas shielded from direct light will also cure to depths of 0.010". Since these materials are based on traditional cyanoacrylate chemistry, specialty primers can be used to develop strong bonds to polyolefins and other difficult-to-bond plastics such as fluoropolymers and acetal resins.

Light curing cyanoacrylate adhesives minimize the potential for "blooming" or "frothing," a white haze which appears around a bondline. This phenomenon occurs when cyanoacrylate monomer volatilizes, reacts with moisture in the air, and settles on the part. With light curing cyanoacrylate adhesives, any adhesive that squeezes out of a bondline or remains on a surface can be rapidly cured with light, minimizing the potential for blooming. Light curing cyanoacrylate adhesives are not subject to oxygen inhibition since free radical species are not part of the curing reaction.

### CHEMISTRY

Light curing cyanoacrylate adhesives are based on ethyl cyanoacrylate esters. Cyanoacrylates undergo an anionic polymerization reaction in the presence of a weak base such as water, and are stabilized through the addition of a weak acid. In addition to the anionic cure mechanism, light curing cyanoacrylates also contain a photoinitiator species which rapidly decomposes when exposed to low intensity light.

## One-Part Heat Cure Epoxies

### ADVANTAGES

- Solvent-free
- High cohesive strength
- High adhesion to a wide variety of substrates
- Tough
- Excellent depth of cure
- Superior environmental resistance
- Dispensing is easily automated

### CONSIDERATIONS

- Require 15- to 45-minute heat cure
- Increased fixture and cure times



### GENERAL DESCRIPTION

Epoxy adhesives are one- or two-part systems that form tough, rigid thermoset polymers with high adhesion to a wide variety of substrates and superior environmental resistance. The viscosities of epoxy adhesives can range from a few thousand cP to thixotropic pastes.

### CHEMISTRY

Epoxy adhesives polymerize to form thermoset polymers when covalent bonds between the epoxy resin and the hardener are formed through the reaction of the epoxide ring with the ring-opening species in the hardener. Amines, amides, mercaptans, and anhydrides are commonly used hardeners. Two-part systems maintain reactive components separately, while one-part systems include the two reactive components within the same formulation. The hardener utilized in typical one-part epoxy products is often referred to as a “latent” hardener that does not become miscible/soluble in the resin until it reaches a specified temperature. Catalysts can be employed to accelerate the reaction rate between the epoxy resin and hardener in both the one- and two-part formulations.

The chemical species that can react with the epoxide end group lead to a wide variety of epoxy formulations available to the end-user. The performance properties of epoxides can be tailored to specific needs using many techniques. Epoxy adhesives are typically rigid and require formulating techniques to produce flexible epoxies, including the use of nonreactive plasticizers, the incorporation of rubber into the epoxy, and the use of epoxy resins with flexible backbones. The properties of epoxy adhesives are also varied through the use of fillers. For example, quartz fillers can impart improved impact resistance; ceramic fillers can offer improved abrasion resistance; and silver can be used to produce epoxies that are electrically conductive.

## Step

# 2 Select Adhesive Candidates

**Appendix 1** (see pp. 22 – 23) presents the key performance attributes for LOCTITE® needle bonding adhesives. This information should be used to select adhesive candidates for further consideration.

Several important selection variables are:

### Viscosity and Flow Time Relationship

Viscosity is the resistance of a fluid to flow. Fluids that flow easily, like water, have a low viscosity. Fluids that do not flow easily, such as window caulk, have high viscosities. Viscosity is typically measured in cP.

The adhesive's viscosity must be selected based on the part design and manufacturing process used. If the cannula will be assembled with the hub before the adhesive is dispensed, a low viscosity (< 3,000 cP) adhesive will ensure fast, consistent fill of the well and core. If the adhesive will be dispensed on the cannula before it is assembled with the hub or there are large gaps between the cannula and the hub, a higher viscosity adhesive (3,000 to 30,000 cP) will ensure that the product does not migrate prior to assembly and/or ensure optimum gap fill.

**Table 2** presents the time required to fill the hub well and core as a function of adhesive viscosity. These flow times were determined using a high-speed camera when dispensing LOCTITE light cure acrylic adhesives on standard specimens that had a 0.002" diametrical gap.

TABLE 2: VISCOSITY-FLOW TIME RELATIONSHIP WITH 0.002" DIAMETRICAL GAP (MINUTE : SECOND)		
VISCOSITY (cP)	MAX. TIME TO FILL WELL	MAX. TIME TO FILL CORE
100	0:05	0:20
500	0:07	0:30
1,000	0:15	1:20
6,000	0:30	3:10
9,000	0:40	4:00

Other factors such as the thixotropic ratio and surface tension of a particular adhesive can dramatically affect flow time. Therefore, the data in **Table 2** should only be used as a general guideline. On-part testing should determine actual flow times required for a specific manufacturing process.

### Occlusion and Flow Time Relationship

Depending on the needle joint design, manufacturers may want to quickly fill the annular space in the core. If the cannula protrudes from the core as shown in **Figure 1A** (on p. 13), the surface tension of the adhesive will typically prevent the adhesive from flowing out of the core. Most needle assemblies are designed with a 0.002" diametrical gap. With this gap, even very low viscosity adhesives (20 cP) will not migrate after prolonged delays before cure. By filling the annular space in the core quickly, needle pull strength will be maximized.

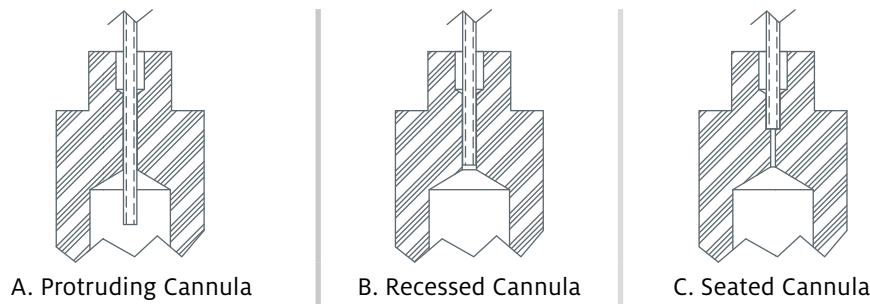

Figure 1: Common Needle Designs

If the cannula ends in the core as shown in **Figures 1B** and **1C**, it is more likely that the adhesive will flow beyond the end of the cannula. Capillary action can then pull the adhesive into the inner diameter of the cannula, obstructing the needle and limiting fluid flow. As the flow time increases, adhesive is more likely to migrate. **Table 3** illustrates the potential for cannula clogs as a function of adhesive viscosity and the flow time between dispense and cure. This testing was conducted using a seated cannula with a 0.002" diametrical gap and a light cure acrylic adhesive.

TABLE 3: OCCLUSION-FLOW TIME RELATIONSHIP			
FLOW TIME	ADHESIVE VISCOSITY (cP)		
	100	500	1,000
7 sec.	–	–	–
14 sec.	Clogs	–	–
5 min.	Clogs	Clogs	–

As an adhesive is heated, its viscosity drops rapidly. For example, an epoxy that has a viscosity of 20,000 cP at room temperature may have a viscosity of 3,000 cP at 65°C. Conversely, if an adhesive is cooled, its viscosity will rise. This viscosity-temperature relationship creates an interesting advantage for one-part heat cure epoxies. Their viscosity will initially drop as the adhesive is heated and will then begin to rise sharply as the adhesive cures, allowing heat cure epoxies to achieve full coverage that would not be possible with light cure acrylic adhesives of the same viscosity dispensed at room temperature.

## Fluorescence

Fluorescent dyes absorb UV light. The energy they absorb excites the dye molecule, emitting a fluorescent light that is typically blue in color. This light can be visually observed with a black light if held over the adhesive in a darkened environment. Detectors can be used alone or in conjunction with vision systems to perform in-line confirmation that the adhesive is present in the bondline.

When fluorescent dye is added to light curing adhesives, the dye decreases the light cure response and can also decrease needle pull strengths. By quantitatively determining the minimum level of fluorescence necessary for robust in-line detection, *LOCTITE* needle bonding adhesives are formulated with the optimum balance of fluorescence, light cure response, and pull strength.

## Cure Speed

Cure speed defines how long the adhesive must be exposed to a given condition before it is fully converted from a liquid to a solid. Cure speed will dictate work-in-process levels. Typically, the rapid cure of light cure acrylics and light cure cyanoacrylates results in minimal work-in-process, whereas the 15-to 25-minute cure times of one-part heat cure epoxies necessitate more in-process time.

## Step

# 3 Review Needle Pull Strength Data to Finalize Candidates

Once initial adhesive candidates have been selected, the next step is to review the performance data of each adhesive to narrow down the field of candidates. Henkel has generated needle pull strength, sterilization resistance, and accelerated aging data to be used by needle manufacturers as a baseline estimate for adhesive performance in a specific needle design.

## Needle Pull Strength

**Appendix 2** (see pp. 24 – 25) presents the needle pull strengths achieved by LOCTITE® needle bonding adhesives. Pull strengths were evaluated on seven different hub plastic types and two different cannula gauge sizes. For more information on the test specimens used, please refer to the Test Methodology (p. 17) section of this guide.

The plastic types evaluated were:

- ABS
- Acrylic
- Polycarbonate (PC)
- Polyethylene (PE)
- Polypropylene (PP)
- Polystyrene (PS)
- Polyurethane (PU)

The cannula gauge sizes evaluated were 22- and 27-gauge. Two different gauge cannulae were selected to represent the upper and lower ends of the commonly used range.

## Effect of Annular Rings

Rings are often molded into the inner diameter of the core and/or well to increase needle pull strength, particularly when the hub material is a difficult-to-bond plastic. The adhesive fills the rings and must be physically deflected for the needle to be moved axially.

In a joint with rings, the adhesion to the hub and the resulting mechanical interlocking will provide a significant contribution to needle pull strength. The lower the adhesion to the hub, the higher the relative contribution of the mechanical interlocking to the needle pull strength. In general, the more rigid the adhesive is, the more difficult it is to deflect the adhesive and the higher the magnitude of the contribution from mechanical interlocking.

The test specimens used for this guide do not have annular rings. Thus, the needle pull strengths presented in this guide are conservative estimates.

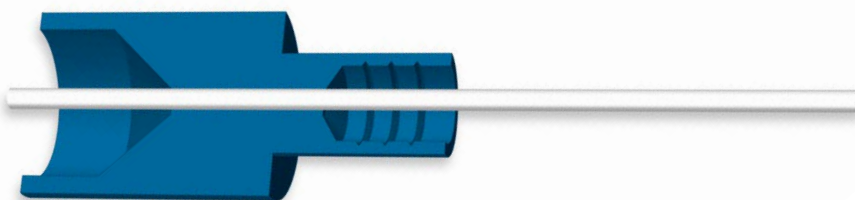
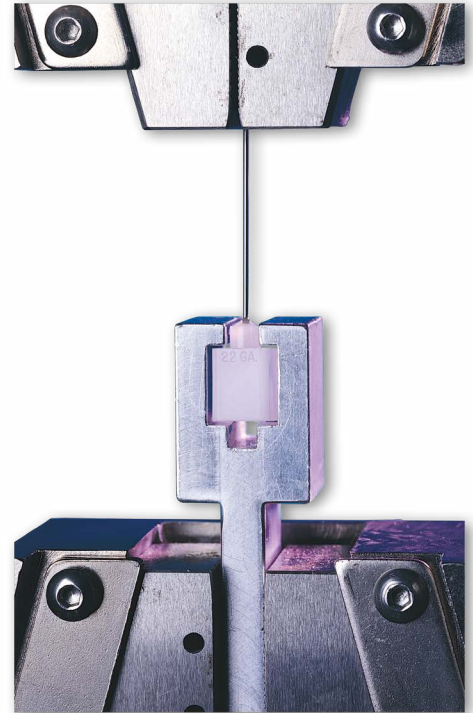

## Sterilization Resistance

All needle assemblies must be sterilized before use. **Appendix 2** (see pp. 24 – 25) presents the effect that gamma, EtO, and autoclave sterilization have on needle pull strength. Since autoclaving is often used for reusable devices, this sterilization method was evaluated for both one and five autoclave cycles.

The sterilization resistance testing was performed on two different size cannulae and three different plastics since both factors can affect the ability of an assembly to maintain pull strength after sterilization.

## Thermal Stability

**Appendix 2** illustrates the thermal stability of *LOCTITE* needle bonding adhesives. Needle manufacturers commonly perform accelerated aging tests to predict the stability of pull strength over the life of the assembly.

This testing was performed on two different size cannulae and three different plastics since both of these factors can affect the relative thermal stability of an assembly with a given adhesive.

## Effect of $T_g$ on Accelerated Aging

Most needle manufacturers perform accelerated aging tests on their needles to predict the performance of the needle over the life of the assembly. Often the Arrhenius or Weibull equations are used to predict the life of the assembly by heating the bonded assembly and correlating a time at an elevated temperature to an equivalent life at ambient conditions. These techniques are based on the assumption that the failure mechanism does not change as the conditioning temperature increases.

When the temperature of the adhesive is above the  $T_g$ , the adhesive softens and the free volume in the polymeric matrix increases dramatically, accelerating the degradation of the adhesive and violating that fundamental assumption. If accelerated aging studies are conducted above the  $T_g$  of the adhesive and the needle assembly will not actually be exposed to these temperatures in service, the results may lead to erroneous conclusions on the reliability of the bonded assembly.

The  $T_g$  does not determine the recommended service temperature range for an adhesive. For example, many epoxies have a  $T_g$  of 50°C – 55°C and have excellent heat aging up to 175°C.



## Step

# 4 Screen Adhesive Candidates by Building Prototypes

Once final adhesive candidates have been selected, the needle designer should screen the candidates on actual assemblies to confirm that the adhesive meets or exceeds all performance requirements. Since screening experiments are often conducted on a larger group of adhesive candidates, the replicates per experimental run are often relatively low; five to 15 observations per experimental run are most common. This step will ensure that the manufacturer is getting results consistent with expectations and is often used to select a smaller group of lead candidates for final qualification testing.

Henkel encourages our needle bonding customers to partner with us when developing adhesive manufacturing processes. Our global engineering support staff will work closely with you to select and qualify adhesives. We often partner with our customers by:

- Recommending adhesive candidates
- Assisting in the qualification process by conducting testing in our facilities
- Reviewing the manufacturing line
- Offering troubleshooting assistance

To contact us, please call 1-800-LOCTITE (562-8483).

## Step

# 5 Qualify Lead Candidates Fully

Once the adhesives have been screened, manufacturers can be confident that the lead candidates will be qualified successfully. The lead candidates will then go through the full qualification test program.



# Test Methodology

## Determining the Experimental Test Matrix

### THE SELECTION OF ADHESIVES

The adhesive families best suited for high speed needle manufacturing operations were identified to be light cure acrylics, light cure cyanoacrylates, and one-part heat cure epoxies. For each of these adhesive families, Henkel has developed a line of adhesives specifically for needle bonding with high pull strengths, fast cure speed, and good fluorescence for automated in-line detection. Fourteen light cure acrylics, two light cure cyanoacrylates, and three one-part heat cure epoxies are included in this guide.

### THE SELECTION OF PLASTICS

Henkel identified the various types of plastics that are commonly used for needle assemblies by surveying needle manufacturers, plastic suppliers, and plastic molders. **Table 4** presents the seven identified plastic types and the specific grades used.

TABLE 4: PLASTIC TYPES USED	TABLE 4: PLASTIC GRADES USED
ABS	Terlux® 2802 TR, Natural
ACRYLIC	Cyrolite® G20-HIFLO, Natural
PC	SABIC® (formerly GE) HP2-112, Natural
PE	Chevron Phillips Marlex® HD 9018 HDPE, Natural
PP	Pro-Fax® SD242, Natural
PS	BASF® 145D
PU	Pellethane® 2363-75D, Natural

Since polyethylene and polypropylene are difficult-to-bond plastics that often require surface treatment to achieve high pull strengths, the effect of plasma treatment was also evaluated on these substrates.

### THE SELECTION OF GAUGE SIZES

Gauge size has a statistically significant effect on the pull strengths achieved by an adhesive. Pull strength decreases as cannula diameter decreases because the smaller circumference of the cannula results in a smaller bond area.

When the gauge size changes, the failure mode can also change. For large gauge sizes, the adhesive often fails to the cannula and remains in the hub. For small gauge sizes, the adhesive often fails to the hub and remains on the cannula.

To investigate the effect of gauge size, two gauge sizes, 22- and 27-, were selected to represent the upper and lower limits of the range of commonly used needles.



# Test Methodology

## Determining the Accelerated Aging Conditions

When qualifying an adhesive for a needle bonding application, most manufacturers have a comprehensive qualification program that evaluates the effect of sterilizing the needle assembly and attempts to evaluate the strength retention of the needle assembly over the life of the needle.

### STERILIZATION RESISTANCE

Light cure acrylics, light cure cyanoacrylates, and one-part heat cure epoxies have excellent resistance to gamma and (EtO) sterilization. Autoclaving is an aggressive sterilization procedure that may adversely affect the performance of needle assemblies.

The sterilization resistance for a needle assembly is dependent on many factors that make it difficult to make generalizations concerning compatibility. Variables that can affect sterilization resistance include, but are not limited to, the adhesive used, the hub substrate, the hub design, the cannula gauge size, and the sterilization profile.

To definitively determine the sterilization resistance of LOCTITE® needle bonding adhesives, industry standard sterilization cycles were selected (see **Table 5**) and evaluated on polycarbonate, polystyrene, and plasma-treated polypropylene hubs with both 22- and 27-gauge needles.

TABLE 5: STERILIZATION CYCLES	
GAMMA	25 to 30 kGy
EtO	STERIS™ cycle 9242
AUTOCLAVE	121°C, 15 psi steam for 6 minutes per cycle

### THERMAL STABILITY

Manufacturers commonly use accelerated aging to decrease time to market with new designs. Accelerated aging is typically comprised of heating the needle assemblies to an elevated temperature, conditioning them at that temperature for a given period, allowing the conditioned assembly to acclimate back to ambient conditions, and determining the pull strength using destructive testing. Many factors affect thermal stability including, but not limited to, the adhesive used, the hub substrate, the hub design, the cannula gauge size, and the conditioning temperature.

To characterize the thermal stability of LOCTITE adhesives, strength retention conditioning at 60°C for four and eight weeks was determined on polycarbonate, polystyrene, and plasma-treated polypropylene hubs with both 22- and 27-gauge needles.



# Test Methodology

## Determining the Test Method

When evaluating the strength achieved by an adhesive, industry standard test specimens such as lap shear and block shear specimens are typically used. Although published testing conducted with standard specimens does give a good indication of the adhesion to a given substrate, these results cannot be extrapolated to performance in a specific needle design. This often makes it impossible for needle manufacturers to select the optimum adhesive for their application without conducting exhaustive and expensive testing.

Henkel could have used cannulae and hubs from medical manufacturers to perform needle pull strength testing on their production assemblies. However, this is not practical when creating data for a selector guide. The proprietary nature of needle designs and the plastic formulations used for needles would make it impossible to share the data with the needle manufacturing community. Lack of control of the test specimens would also make it difficult to generate historical performance data.

To overcome these limitations, Henkel has designed a test specimen that simulates a standard needle bonding joint. **Figure 2** details the hub design. The only dimension that changes from 22- to 27-gauge specimens is the inner diameter of the core on the hub. The inner diameter of the core is designed to have a 0.002" diametrical gap with the cannula for both gauge sizes. Unsharpened cannulae were provided by a major needle manufacturer for this testing.

There are no annular rings in the well or the core of the test specimen. Often annular rings are added to increase pull strength by adding mechanical interlocking. Since annular rings were not molded into the standard test specimens, the pull strengths presented in this guide are a conservative estimate of the pull strength that will be achieved if annular rings are used.

Figure 2: *LOCTITE* Needle Specimen  
(inches)

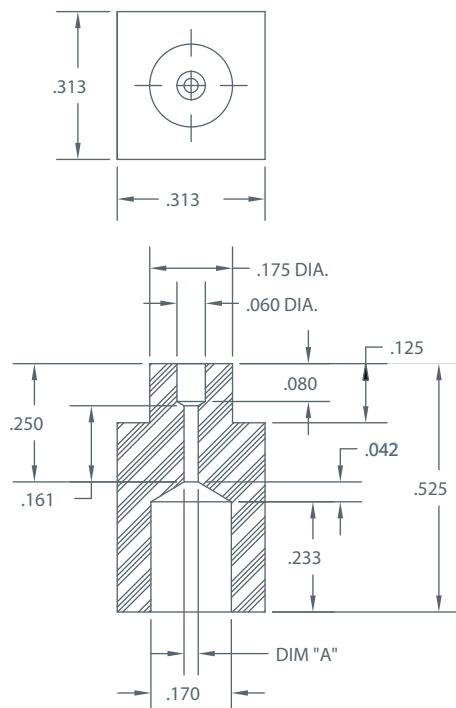

DIMENSION "A"			
GAUGE SIZE	HUB INNER DIAMETER	CANNULA OUTER DIAMETER	DIAMETRICAL GAP
22	0.030"	0.028"	0.002"
27	0.018"	0.016"	0.002"

Note: *LOCTITE* Needle Specimen did not incorporate annular rings.

# Test Methodology

## Experimental Procedure

### SURFACE PREPARATION

1. All cannulae were cleaned with isopropyl alcohol.
2. If indicated, the hubs were plasma-treated in oxygen on level 10 for 10 minutes.

### ADHESIVE APPLICATION AND CURE METHOD

1. The adhesive was manually dispensed using a LOCTITE® Analog Syringe Dispensing System.
  - 1.1. For adhesives with a viscosity of less than 3,000 cP, the adhesive was applied after assembling the cannula and hub.
    - 1.1.1. The cannula was manually inserted into the hub.
    - 1.1.2. A small drop of adhesive was applied at the cannula to hub interface. The adhesive quantity was set to ensure that the adhesive completely filled the well, creating a domed adhesive fillet.
  - 1.2. For adhesives with a viscosity of greater than or equal to 3,000 cP, the adhesive was applied before assembling the cannula and hub.
    - 1.2.1. A small drop of adhesive was applied to the cannula approximately 0.063" from the end to be mated to the hub. The adhesive quantity was set to ensure that the adhesive completely filled the well, creating a domed adhesive fillet.
    - 1.2.2. The cannula was manually inserted into the hub.
2. The adhesive was allowed to flow for the time indicated in **Table 6**.

TABLE 6: FLOW TIME VS. VISCOSITY	
VISCOSITY (cP)	FLOW TIME (MINUTE : SECOND)
100 – 499	0:30
500 – 999	0:40
1,000 – 8,999	1:30
> 9,000	4:10

3. The adhesive was cured.
  - 3.1. For light cure adhesives, the needle specimens were cured in a high intensity electrodeless light cure chamber with an irradiance of 850 to 1000 mW/cm<sup>2</sup> at 365 nm for 10 seconds.
  - 3.2. For heat cure epoxies, the needle specimens were cured for 30 minutes at 100°C.

### CONDITIONING

1. If indicated, the needle assemblies were sterilized using the cycles described in **Table 5**.
2. If indicated, the needle assemblies were heat aged in a forced air convection oven.

### TEST METHOD

1. Assemblies were tested in the LOCTITE needle pull fixture on an Instron® 4204 mechanical properties tester equipped with a 1 kN load cell at a pull speed of 4"/minute.
2. Ten replicates of each assembly were tested.

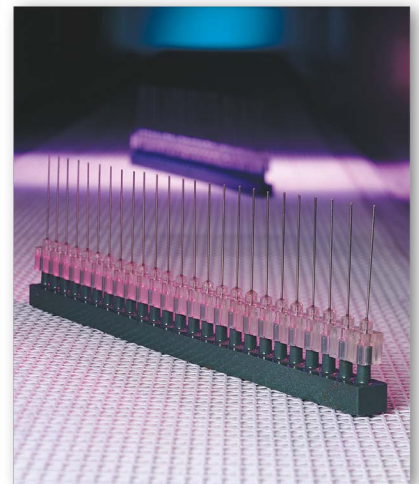

# Equipment

Henkel offers a complete line of *LOCTITE* dispensing, curing and process monitoring equipment designed specifically for use with *LOCTITE* high performance adhesives. Dispense and curing options range from handheld, manual and semiautomatic systems to fully automatic and custom engineered systems for turnkey integration in high speed assembly processes.

## LOCTITE® EQ CL28 CureJet LED

*LOCTITE* EQ CL28 CureJet™ LEDs are our highest power LED spot curing systems. Innovative design offers a wide cure area and curing intensity capability.

PART NUMBER	DESCRIPTION
1364033	<i>LOCTITE</i> Single Controller
2183340	<i>LOCTITE</i> EQ CL28 CureJet™ LED Spot – 405 nm
1370352	<i>LOCTITE</i> 3m Interconnecting Cable
1370351	<i>LOCTITE</i> 1m Interconnecting Cable



*LOCTITE* EQ CL28 CureJet™ LED Spot – 405 nm shown with controller and cable (sold separately)

## LOCTITE® EQ Valves

*LOCTITE* EQ VA10 Micro Diaphragm Valve is a miniature dispensing valve designed to dispense precision drops and beads of low-to-medium viscosity adhesive. Its compact size allows for closer center-to-center spacing for multiple point dispensing in applications like needle bonding. Lightweight feature allows for faster motion control movements when mounted.

*LOCTITE* EQ VA20 Volumetric Valve is a positive displacement metering valve that dispenses a precise volumetric drop of adhesive with each cycle. Designed with a flooded chamber and a single check valve that improves the speed and reliability of priming, and minimizes the need for re-priming. It is specifically designed to dispense *LOCTITE* light cure adhesives with precise dosing in the range of 1.5 to 12 microliters.



*LOCTITE* EQ VA10 Diaphragm Valve (left)  
*LOCTITE* EQ VA20 Volumetric Valve (right)

PART NUMBER	DESCRIPTION
1611449	<i>LOCTITE</i> EQ VA10 Micro Diaphragm Valve
2084141	<i>LOCTITE</i> EQ VA20 Volumetric Valve

## LOCTITE® Radiometer Dosimeters

An industry first for the measurement of LED Light Curing devices. The flat response curve makes them uniquely qualified to measure narrow band wavelengths of LED light. They can also be used with traditional arc-lamps in curing chambers, conveyors, and flood lamps. This unit combines the all-in-one exposure, intensity measurement, and profile memory capabilities into one device.

PART NUMBER	DESCRIPTION
2436353	<i>LOCTITE</i> EQ PM20 UV AB Radiometer/Dosimeter
2436352	<i>LOCTITE</i> EQ PM20 UV VIS Radiometer/Dosimeter



*LOCTITE* Radiometer Dosimeter

# Appendix 1

## LOCTITE® Adhesive Selector Chart

All LOCTITE Needle Bonding Adhesives are ISO 10993 compliant.

PRODUCT NAME	KEY PRODUCTS ATTRIBUTES																						
	COLOR	VISCOSITY (cP)	RELATIVE FLUORESCENCE (IN UNCURED STATE)	FIXTURE TIME (SEC.)		TACK-FREE TIME (SEC.)		CURE SCHEDULE	TENSILE STRENGTH (PSI)	ELONG. TO BREAK (%)	MODULUS (PSI)	HARDNESS, SHORE D	% WATER ABSORPTION		T <sub>g</sub> (°C)	BLOCK SHEAR STRENGTH (PSI)							
				30 mW/cm <sup>2</sup>	30 mW/cm <sup>2</sup>	100 mW/cm <sup>2</sup>	2 HR. BOIL						7 DAY RT	ACRYLIC		EPOXY*	NYLON*	PBT*	PC	PVC*	ALUMINUM*	STEEL*	
<b>LIGHT CURE ACRYLIC</b>																							
LOCTITE AA 3921™	Transparent to Hazy	150	High	< 5	> 60	> 60	10 sec. at 100mW/cm <sup>2</sup> to 0.082 in.	2,830	32	122,750	67	5.9	8.8	82	1,120	1,130	490	800	3,060	750	2,150	2,390	
LOCTITE AA 3922™	Transparent to Hazy	300	Moderate	< 5	> 60	> 60	10 sec. at 100mW/cm <sup>2</sup> to 0.115 in.	2,600	135	91,500	66	7.2	14.2	75	1,010	1,840	610	1,040	3,410	810	2,080	2,170	
LOCTITE AA 3924™	Transparent to Hazy	1,100	High	< 5	> 60	> 60	10 sec. at 100mW/cm <sup>2</sup> to 0.096 in.	2,610	280	41,100	60	5.5	6.4	61	1,120	1,240	550	970	2,350	710	1,450	1,460	
LOCTITE AA 3926™	Transparent to Hazy	5,500	High	< 5	> 60	> 60	10 sec. at 100mW/cm <sup>2</sup> to 0.100 in.	2,740	331	20,700	57	5.1	5.1	58	970	1,070	590	850	2,910	640	1,360	1,330	
LOCTITE AA 3936™	Transparent to Hazy	10,000	Moderate	< 5	> 60	> 60	10 sec. at 100mW/cm <sup>2</sup> to 0.080 in.	2,780	300	24,500	55	4.1	3.0	66	670	1,170	790	690	2,760	830	1,140	1,400	
LOCTITE AA 3942™	Transparent to Hazy	1,100	Moderate	< 5	45 – 60	5 – 10	10 sec. at 100mW/cm <sup>2</sup> to 0.114 in.	4,160	15	142,900	76	5.0	4.8	55	530	720	500	680	830	720	1,840	2,110	
LOCTITE AA 3943™	Transparent to Hazy	6,000	Moderate	< 5	45 – 60	5 – 10	10 sec. at 100mW/cm <sup>2</sup> to 0.122 in.	3,480	271	64,000	69	4.4	4.2	55	810	1,020	720	670	1,090	1,240	1,600	1,420	
<b>TOP CHOICE</b> LOCTITE AA 3961™	Transparent, Colorless to Straw	55	High	< 5	N/A	< 5**	10 sec. at 1.4 W/cm <sup>2</sup> to 0.177 in.	4,050	4.5	181,000	75	5.9	N/A	49.5	655	N/A	–	–	3,210	3,200	1,070***	1,350***	
<b>TOP CHOICE</b> LOCTITE AA 3963™	Transparent, Colorless to Straw	350	High	< 5	N/A	5 to 10**	10 sec. at 1.4 W/cm <sup>2</sup> to 0.177 in.	3,356	38	144,000	71	6.2	N/A	55	807	–	–	–	3,298	3,330	1,011***	1,011***	
LOCTITE AA 3971™	Transparent to Hazy	300	Moderate	< 5	5 – 10	< 5	10 sec. at 100mW/cm <sup>2</sup> to 0.159 in.	3,730	93	95,000	71	9.8	13.3	52	1,690	1,010	360	640	3,150	800	2,520	1,930	
LOCTITE AA 3972™	Transparent to Hazy	4,500	Moderate	< 5	< 5	< 5	10 sec. at 100mW/cm <sup>2</sup> to 0.247 in.	3,730	88	66,750	68	7.2	8.3	49	690	1,190	330	740	2,200	610	1,570	1,850	
<b>LIGHT CURE CYANOACRYLATE</b>																							
LOCTITE 4306™ Flashcure®	Translucent Green	20	Moderate	< 5	< 5	< 5	10 sec. at 100mW/cm <sup>2</sup> to 0.152 in.	4,720	2.2	250,700	82	2.0	1.1	116	320	720	160	540	2,200	260	1,590	1,460	
LOCTITE 4307™ Flashcure®	Translucent Green	900	Moderate	< 5	< 5	< 5	10 sec. at 100mW/cm <sup>2</sup> to 0.172 in.	4,840	2.2	262,900	82	2.6	1.2	114	320	470	240	690	2,060	410	870	1,480	
<b>HEAT CURE EPOXY</b>																							
LOCTITE EA 3984™	Light Grey	25,500	Superior	N/A	N/A	N/A	25 min. @ 100°C 24 min. @ 125°C 17 min. @ 150°C	5,540	1.1	566,000	84	1.6	0.4	74	560	2,450	820	1,640	305	N/A	4,580	6,590	

\*Bonded to glass for light cure adhesives and to itself for epoxies.

\*\*At 1.4 W/cm<sup>2</sup>

\*\*\*Adhesion test performed by bonding named substrate to PC lapshear. All test replicates resulted in substrate failure.

# Appendix 2

## Needle Pull Strength Data

PRODUCT NAME	NEEDLE PULL STRENGTHS									STERILIZATION RESISTANCE									THERMAL STABILITY OF NEEDLES							
	STRENGTH (lb-F) HUB MATERIAL									% STRENGTH RETENTION AFTER STERILIZATION									% STRENGTH RETENTION AFTER 60°C HEAT AGING							
	ABS	ACRYLIC	PC	PE	PE*	PP	PP*	PS	PU	GAMMA			EtO			AUTOCLAVE			PC		PP*		PS			
									PC	PP*	PS	PC	PP*	PS	1 CYCLE		5 CYCLES		4	8	4	8	4	8		
															PC	PP*	PC	PP*	WEEKS	WEEKS	WEEKS	WEEKS	WEEKS	WEEKS		
22-GAUGE NEEDLE	LOCTITE® AA 3921™	61	56	50	10	35	12	45	45	34	120	95	105	120	105	105	105	100	95	95	150	155	105	100	175	175
	LOCTITE AA 3922™	55	54	46	11	40	17	49	40	35	90	80	105	110	85	115	80	125	80	120	85	85	60	65	105	105
	LOCTITE AA 3924™	32	32	27	3	22	5	27	21	28	155	130	130	150	125	130	110	115	130	110	165	110	130	80	180	165
	LOCTITE AA 3926™	18	19	24	4	19	4	20	15	19	115	115	110	90	105	120	85	90	80	75	115	80	135	115	90	85
	LOCTITE AA 3936™	22	23	33	7	17	18	18	31	25	65	95	55	105	110	95	100	85	65	75	105	100	85	90	95	100
	LOCTITE AA 3942™	62	57	61	6	52	21	46	59	42	85	110	90	90	90	85	90	90	80	55	105	75	95	85	105	135
	LOCTITE AA 3943™	55	50	59	3	39	8	26	43	43	95	155	115	80	130	100	75	120	65	90	95	95	90	155	110	140
	LOCTITE AA 3961™	71	72	70	16	47	13	52	60	52	88	100	N/A	115	102	N/A	60	71	43	52	112	107	89	93	N/A	N/A
	LOCTITE AA 3963™	78	73	69	6	43	6	37	73	50	80	73	N/A	121	126	N/A	83	98	84	104	117	123	126	108	N/A	N/A
	LOCTITE AA 3971™	41	44	40	3	28	5	7	46	41	95	90	100	45	160	85	30	70	5	60	50	50	85	100	60	60
	LOCTITE AA 3972™	40	41	40	1	38	3	6	33	38	105	100	115	100	115	135	10	65	10	65	70	55	85	85	90	85
	LOCTITE EA 3984™	51	57	24	3	45	6	33	50	44	105	90	90	100	100	75	110	65	30	35	190	190	120	150	100	110
	LOCTITE 4306™ Flashcure®	31	43	55	9	22	4	12	22	22	55	75	65	75	90	55	45	40	25	50	100	100	100	40	60	70
	LOCTITE 4307™ Flashcure®	40	34	26	1	22	1	4	20	33	120	75	75	90	75	135	25	75	20	75	40	35	200	125	125	70
27-GAUGE NEEDLE	LOCTITE AA 3921™	27	27	24	9	22	7	28	20	23	125	110	130	115	115	150	80	105	105	90	130	115	115	100	175	175
	LOCTITE AA 3922™	19	19	14	4	17	5	21	15	18	195	145	175	115	150	165	130	145	120	140	180	200	145	150	160	165
	LOCTITE AA 3924™	16	18	11	3	22	5	22	11	13	150	110	130	135	110	120	105	95	115	80	115	115	115	100	170	140
	LOCTITE AA 3926™	12	13	10	4	16	8	17	6	11	95	125	100	105	110	165	85	85	105	70	105	100	105	80	150	120
	LOCTITE AA 3936™	17	16	16	8	17	10	16	16	14	150	135	185	115	120	120	90	115	40	100	85	85	60	105	135	125
	LOCTITE AA 3942™	35	37	37	19	30	14	33	36	32	105	80	90	95	80	85	75	90	55	55	90	90	75	45	85	100
	LOCTITE AA 3943™	34	33	33	12	26	10	26	32	27	90	100	100	105	105	105	85	95	65	95	110	75	70	85	120	100
	LOCTITE AA 3961™	34**	35**	34**	21	34**	7	33**	31	31	83	88	N/A	101	106	N/A	90	88	30	66	98	83	102	96	N/A	N/A
	LOCTITE AA 3963™	34**	35**	36**	8	32	4	33**	37**	35	113	91	N/A	94	121	N/A	88	105	38	104	98	91	100	106	N/A	N/A
	LOCTITE AA 3971™	21	29	18	3	25	2	5	27	25	90	100	110	55	80	65	55	120	5	80	65	45	60	60	55	60
	LOCTITE AA 3972™	22	23	16	1	23	2	4	19	26	90	100	105	55	125	65	25	75	10	75	75	65	85	80	45	45
	LOCTITE EA 3984™	32	33	26	12	31	8	26	30	31	90	80	75	80	70	80	100	110	75	65	110	110	105	105	100	100
	LOCTITE 4306™ Flashcure®	7	3	20	4	10	2	5	2	11	30	80	50	40	100	150	15	40	25	80	90	60	80	80	100	100
	LOCTITE 4307™ Flashcure®	2	2	2	1	5	1	3	2	6	50	50	50	200	100	100	100	65	100	65	100	100	200	165	50	100

\*Plasma treated.  
 \*\*50% or more of the replicates exhibited substrate failure at the cannula

# Product Ordering Information

## Light Cure Acrylic Adhesives

PRODUCT	PACKAGE SIZE	ITEM NUMBER
LOCTITE® AA 3921™	25 ml syringe	434102
	1 L bottle	434103
LOCTITE AA 3922™	25 ml syringe	312057
LOCTITE AA 3924™	25 ml syringe	434105
	1 L bottle	434106
LOCTITE AA 3926™	25 ml syringe	434108
	1 L bottle	434109
LOCTITE AA 3936™	25 ml syringe	312050
LOCTITE AA 3942™	25 ml syringe	434101
	1 L bottle	434089
LOCTITE AA 3943™	25 ml syringe	434088
	1 L bottle	434084
LOCTITE AA 3961™	25 ml syringe	2464890
	1 L bottle	2464891
LOCTITE AA 3963™	25 ml syringe	2483476
	1 L bottle	2483477
LOCTITE AA 3971™	25 ml syringe	444350
	1 L bottle	444375
LOCTITE AA 3972™	25 ml syringe	423298
	1 L bottle	423299

## Epoxies

PRODUCT	PACKAGE SIZE	ITEM NUMBER
LOCTITE EA 3984™	30 ml syringe	443949

## Light Cure Cyanoacrylates

PRODUCT	PACKAGE SIZE	ITEM NUMBER
LOCTITE 4306™ Flashcure®	1 oz. bottle	487909
	1 lb. bottle	487921
LOCTITE 4307™ Flashcure®	1 oz. bottle	487920
	1 lb. bottle	487922

# Technical Support

## E-CATALOG

Gain quick and easy access to product and equipment descriptions, approvals/specifications, application suggestions, package specifications, and technical and material safety data.

## APPLICATION ASSISTANCE

Application assistance will aid in narrowing the range of products suitable for your design and maintenance needs. Also, send a message to your local Adhesives and Sealant Specialist to arrange "in person" assistance.

## DISTRIBUTOR LOCATOR

Find a local distributor in the U.S. or Canada that has the product you need. All it takes is a zip code.

## DATA SHEETS AND LITERATURE

Instant access to technical and material safety data sheets. On the web, view electronic versions of *LOCTITE* catalogs, design and bonding guides, quick reference tools, and other special literature. Or order hard copies to be delivered to your door.

## WHAT'S NEW

Find out about new product introductions, feature articles, trade show schedules, and application success stories. Register for *LOCTITE* adhesives seminars.

## Literature

### EQUIPMENT SOURCEBOOK

This engineering manual gives a detailed review of *LOCTITE* adhesive dispensing, light curing, and process monitoring equipment. Also included are dispensing needles, spare parts and accessories, equipment support programs, and custom equipment capabilities.

**Request LT-3669**

Visit [henkelna.com/medicaladhesives](http://henkelna.com/medicaladhesives)  
or call **1-800-LOCTITE (562-8483)**

### LOCAL LOCTITE BRAND ADHESIVES AND SEALANT SPECIALIST

Tel: +1.800.323.5106

[henkelna.com/medicaladhesives](http://henkelna.com/medicaladhesives)

### NEAREST AUTHORIZED LOCTITE BRAND DISTRIBUTOR

### ARRANGE AN IN-PLANT SEMINAR

Technical Product Assistance

Tel: +1.800.LOCTITE (+1.800.562.8483)

### TO PLACE AN ORDER

USA: +1.800.243.4874

Canada: +1.800.263.5043

Mexico: +01.800.436.5357

Latin America: +55.11.4143.7000





## USA

Henkel Corporation  
14000 Jamboree Road  
Irvine, CA 92606  
USA  
Tel: +1.888.943.6535  
Fax: +1.310.605.2274

Henkel Corporation  
20021 Susana Road  
Rancho Dominguez, CA 90221  
USA  
Tel: +1.310.764.4600  
Fax: +1.310.605.2274

Henkel Corporation  
18930 W. 78th Street  
Chanhassen, MN 55317  
USA  
Tel: +1.952.835.2322  
Tel: +1.800.347.4572  
Fax: +1.952.835.0430

Henkel Corporation  
One Henkel Way  
Rocky Hill, Connecticut 06067  
United States  
Tel: +1.860.571.5100  
Fax: +1.860.571.5465

## Canada

**HENKEL CANADA CORPORATION**  
2515 Meadowpine Blvd.  
Mississauga, Ontario  
Canada L5N 6C3  
Tel: +1.800.263.5043 (within Canada)  
Tel: +1.905.814.6511  
Fax: +1.905.814.5391

## Mexico

**HENKEL CAPITAL S.A. DE C.V. (MEXICO)**  
Boulevard Magnocentro No. 8 Piso 2  
Centro Urbano Interlomas  
52760 Huixquilucan, Estado de México  
Mexico  
Tel: +52.55.3300.3000  
Fax: +52.55.3300.3062

## Latin America

**HENKEL LTDA.**  
Rua Karl Huller, 136 - Jd.  
Canhema 09941-410  
Diadema/SP, Brazil  
Tel: +55.11.3205.8955  
Fax: +55.11.3205.8766

**HENKEL ARGENTINA S.A.**  
1357 Nicolás Avellaneda Street  
B1642EYA San Isidro,  
Buenos Aires  
Argentina  
Tel: +54.11.4001.0100  
Fax: +54.11.4001.0158

**HENKEL CHILE S.A.**  
Avenida Laguna Sur 9551  
Parque Industrial Puerto  
Santiago, Comuna de Pudahuel  
9060987 Región  
Metropolitana de Santiago  
Chile  
Tel: +56.2.381.7300  
Fax: +56.2.641.8143

## HENKEL COLOMBIA S.A.

Calle 17 No. 68b-97  
Zona Industrial de Montevideo  
Bogotá D.C., Colombia  
Tel: +57.1.423.8900  
Fax: +57.1.423.8993

## HENKEL VENEZUELA S.A.

Calle 2, Carretera Nacional  
Guacara - San Joaquín  
Zona Industrial Pruinca  
Guacara - Estado de Carabobo,  
Venezuela  
Tel: +58.245.560.2611  
Fax: +58.245.564.2736  
**HENKEL LTDA.**  
Rua Karl Huller, 136 - Jd.  
Canhema 09941-410  
Diadema/SP, Brazil  
Tel: +55.11.3205.8955  
Fax: +55.11.3205.8766

**Across the Board,  
Around the Globe.** 

[henkelna.com/medicaladhesives](http://henkelna.com/medicaladhesives)  
[henkel-adhesives.com/electronics](http://henkel-adhesives.com/electronics)

## DISCLAIMER

Henkel Corporation cannot assume responsibility for the results obtained by others over whose methods we have no control. It is the user's responsibility to determine suitability for the user's purpose of any production method mentioned herein and to adopt such precautions as may be advisable for the protection of property and of persons against hazards that may be involved in the handling and use thereof. In light of the foregoing, Henkel Corporation specifically disclaims all warranties of merchantability or fitness for a particular purpose arising from sale or use of *LOCTITE* products. Henkel specifically disclaims any liability for consequential or incidental damages of any kind, including lost profits. The discussion herein of various design criteria is not to be interpreted as representation that they are free from domination of patents owned by others or as a license under any Henkel patents which may cover such processes or compositions. We recommend that each prospective user test the proposed application in its manufacturing process using this data as a guide. The products and processes in this guide may be covered by one or more United States or foreign patents or patent applications.