

EQ CL30 LED Flood 365 / 380 / 405**2139182 / 2139181 / 2139180****PRODUCT DESCRIPTION**

The CL30 LED Flood System is a high intensity flood system specially designed for curing Loctite® UV and Visible Light Cure adhesives. The modular configuration consists of an LED head with connection cable, and controller (each ordered separately), and the system is offered in either 365, 380, or 405 nm wavelengths. Each CL30 head is equipped with 144 high power LED's and integrated reflectors, providing uniform curing across a wide area (100 mm x 100 mm or 4 inches by 4 inches). The heads can also be stacked side by side in two directions further expanding the curing area for maximum flexibility. The expected lifetime of the LED's is more than 20.000 hours under normal operating conditions. The CL30 system is compatible with manual work stations as well as automated production lines. It can be operated via a footswitch or a PLC and run in either timer or continuous mode.

**Product Properties**

- High UV intensity – Up to 1 W/cm²
- LED heads stackable in two directions
- Expected LED life over 20,000 hours (30% intensity decay) with proper handling
- 100% duty cycle
- Instant on/off, no heat up or cool down necessary
- Optimal curing distance: 50 mm
- Compact system with integrated air cooling
- Requires LED Flood Controller, sold separately
- Temperature and voltage monitor of LEDs

Benefits:

- Lasts up to 10 times longer than traditional arc lamps with negligible output decay during duty cycle
- 100% of the emitted light is within the range of the curing spectra of the adhesive (when compared to Mercury vapor arc lamps)
- Energy efficient, LEDs produce little wasted energy
- Each LED head has been optimized for its specific wavelength (365 nm, 380 nm, 405 nm)
- Air cooling system maintenance free

Technical Data:

- Recommended working distance: 25 – 75 mm
- Wavelength: 365, 380 or 405 nm
- Peak Intensity (Distance 50 mm):
>800 mW/cm² for 365 nm
>1250 mW/cm² for 380 nm
>1500 mW/cm² for 405 nm
- Evenness: Tolerance <30% (Distance 50 mm)
- Noise level: <66 dBA (Distance 1 m)
- Weight: 1.5 kg

Intensity is measured at 25 spots, see diagram on the right. Measuring device: Radiometer / Dosimeter UV-A/B and UV-V, see optional accessories.

Evenness is measured at nine different spots, shown on the right.

Evenness = (max - min) / (max + min)

Optional Accessories:

LED Flood Controller 97104 (for one head), order no. 1359255

LED Flood Controller XXX (for up to four heads), order no. TBD

LED Flood Chamber 97360 (for up to two heads), order code 1511839

UV Safety Glasses, yellow, recommended for 405 nm, order no. 1175128

UV Safety Glasses, grey, recommended for 365 and 380 nm, order no. 1175128

Protection Gloves, white, 1 pair, order no. 376746

Radiometer / Dosimeter UV-A/B, for 365 and 380 nm, order no. 1390323

Radiometer / Dosimeter UV-V, for 405 nm, order no. 1265282

Items supplied:

- CL30 LED Flood 365/380/405
- Connecting Cable Head to Controller

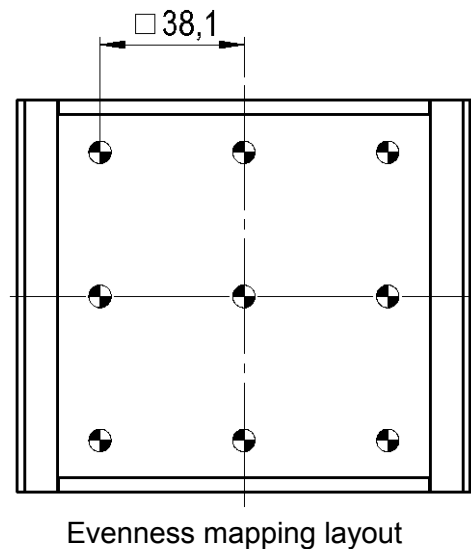
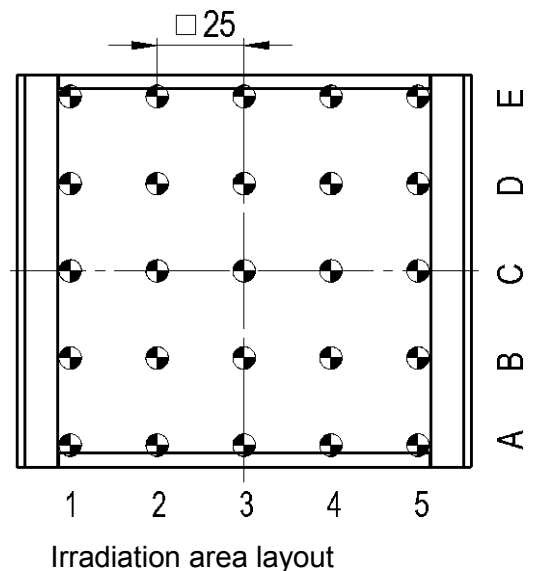

Sample Data:

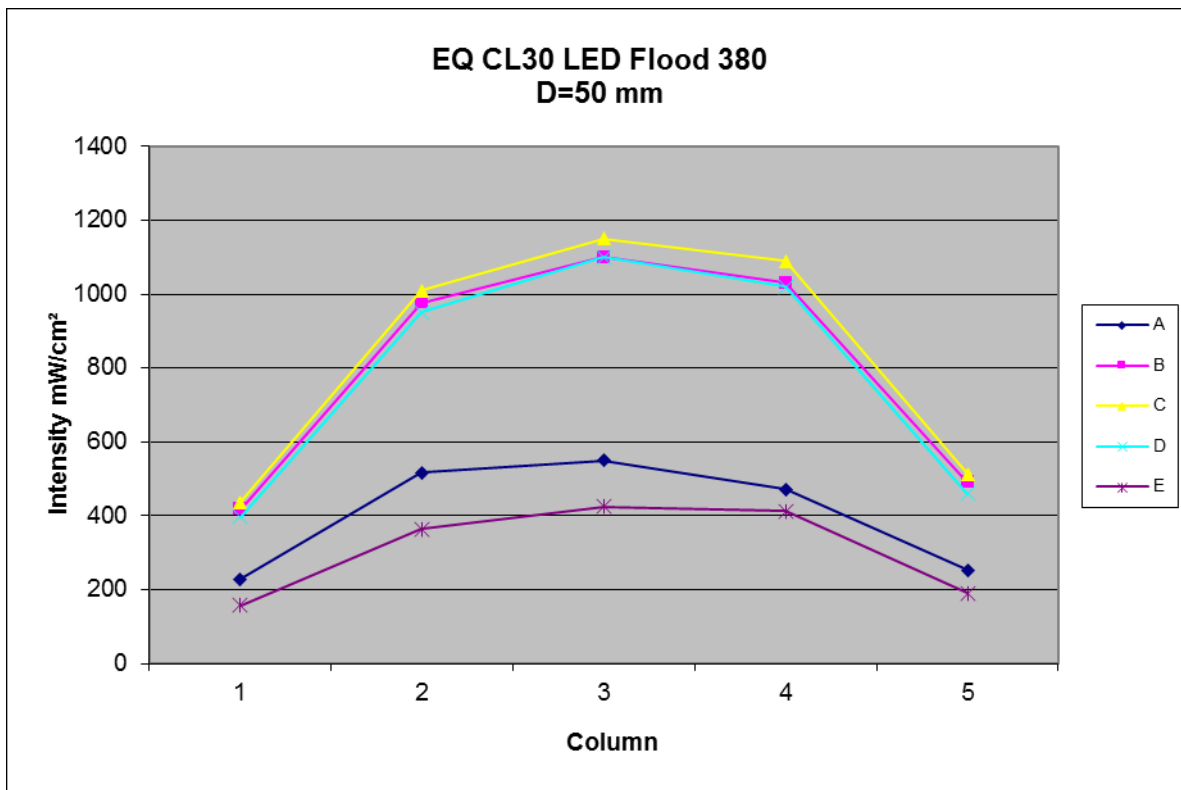
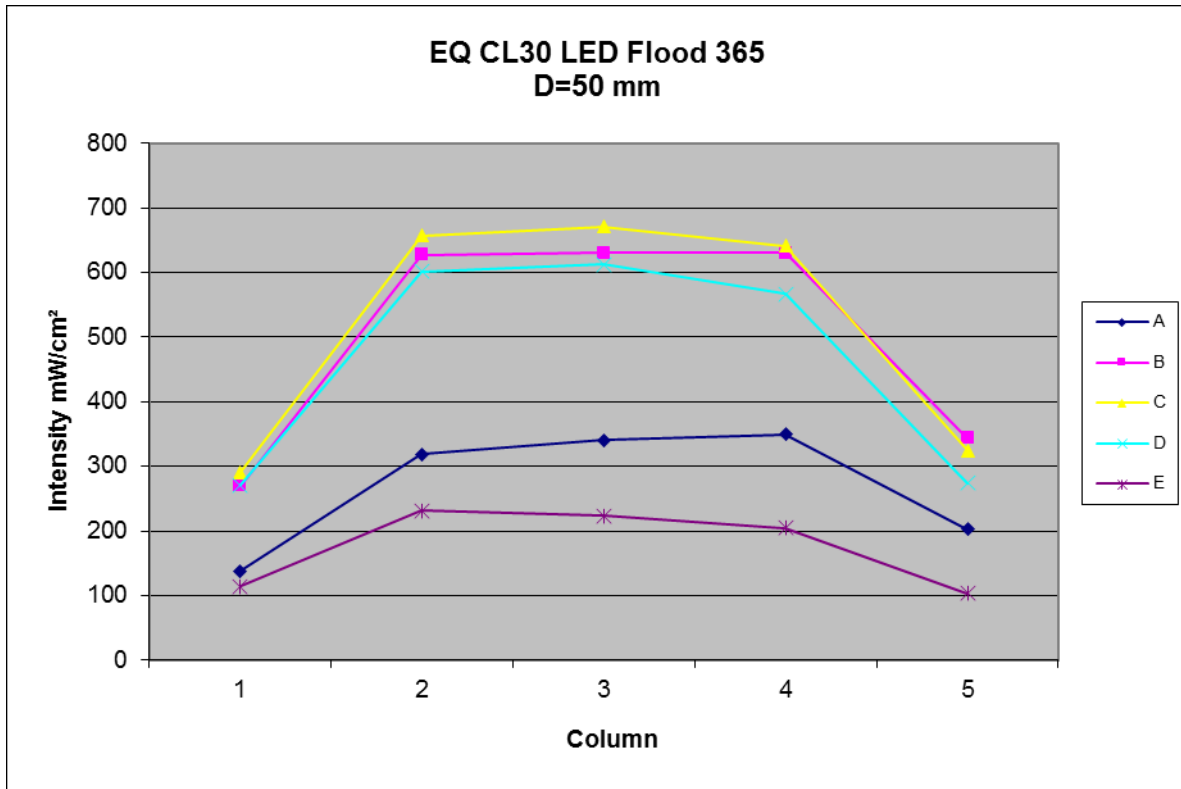

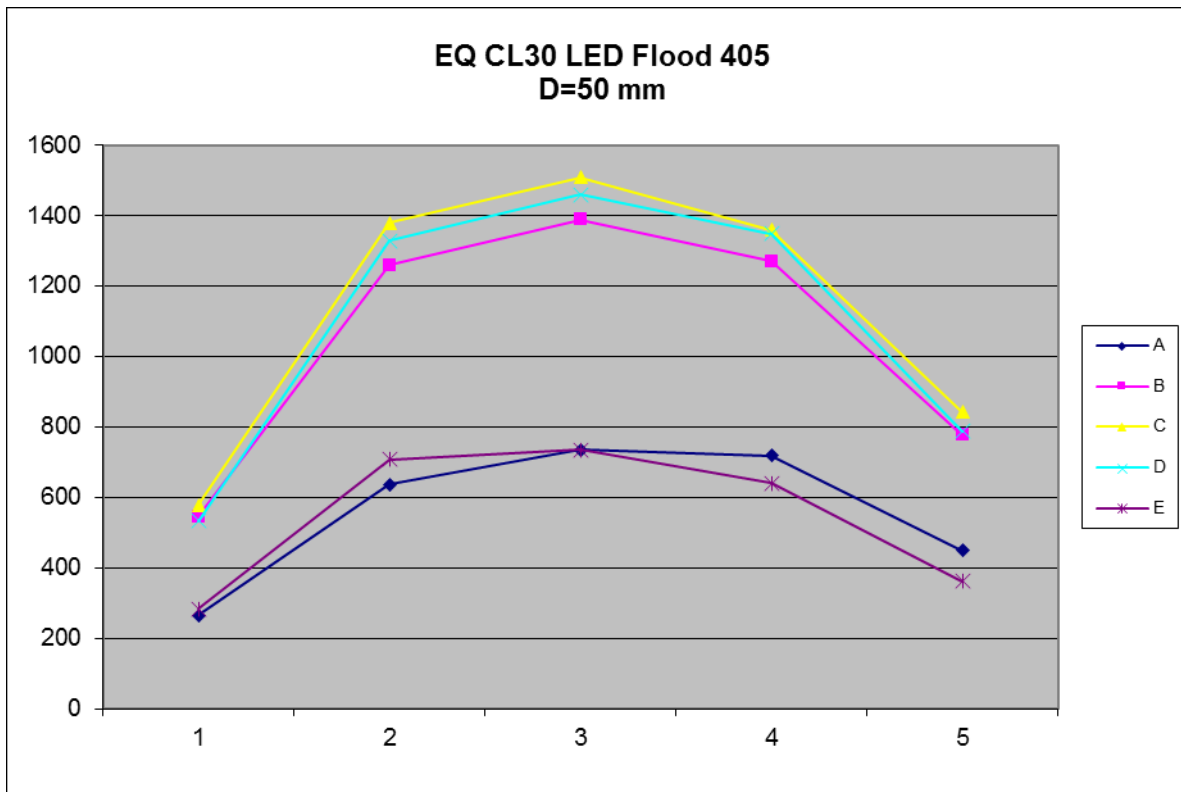

Dimensions:

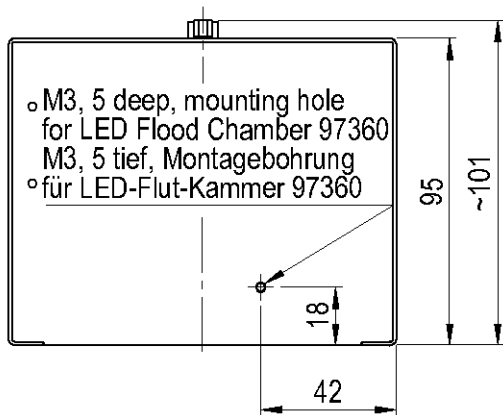
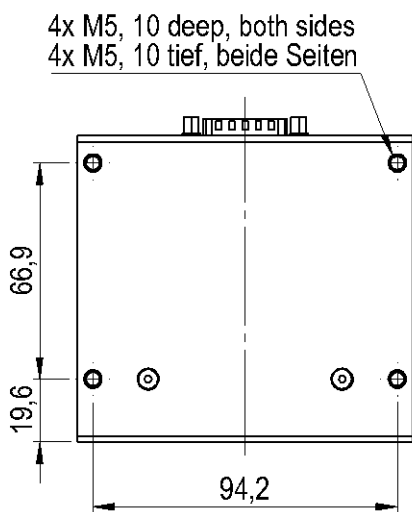
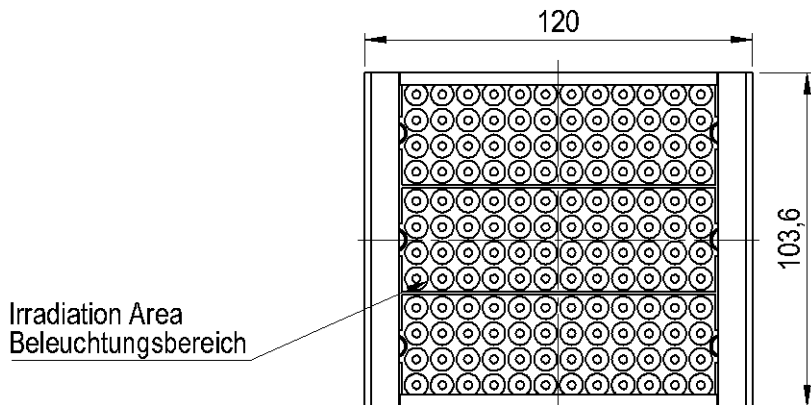

Example for Carrier Rail
Beispiel für Tragschiene

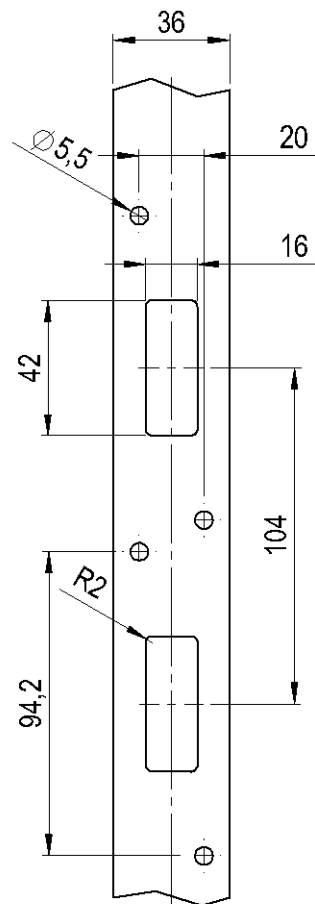

Air flow, intake/exhaust on top
Minimum clearance: 50 mm
Luftstrom, Einlass/Auslass oben,
Mindestabstand: 50 mm

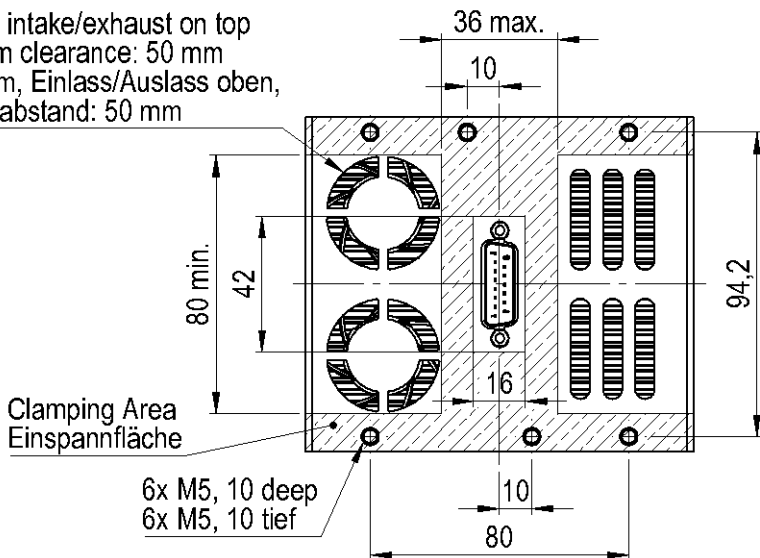

Note
The data contained herein are furnished for information only and are believed to be reliable. We cannot assume responsibility for the results obtained by others over whose methods we have no control. It is the user's responsibility to determine suitability for the user's purpose of any production methods mentioned herein and to adopt such precautions as may be advisable for the protection of property and of persons against any hazards that may be involved in the handling and use thereof. In light of the foregoing, Henkel Corporation specifically disclaims all warranties expressed or implied, including warranties of merchantability or fitness for a particular purpose, arising from sale or use of Henkel Corporation's products. Henkel Corporation specifically disclaims any liability for consequential or incidental damages of any kind, including lost profits. The discussion herein of various processes or compositions is not to be interpreted as representation that they are free from domination of patents owned by others or as a license under any Henkel Corporation patents that may cover such processes or compositions. We recommend that each prospective user test his proposed application before repetitive use, using this data as a guide. This product may be covered by one or more United States or foreign patents or patent applications.

Trademark usage except as otherwise noted, all trademarks in this document are trademarks of Henkel Corporation in the U.S. and elsewhere. ® denotes a trademark registered in the U.S. Patent and Trademark Office.