

LOCTITE®
BONDERITE®
TEROSON®

Adhesives, Sealants, Functional Coatings, and Services
Rail Sourcebook



Henkel

HENKEL: YOUR TOTAL SOLUTIONS PROVIDER FOR THE RAIL INDUSTRY

SOLUTIONS FOR EVERY STEP OF YOUR PROCESS



BODY SHOP

METAL

- Metalworking Fluids
- Cleaning
- Corrosion Protection

PAINTING

- Cleaning
- Pre-Treatment
- NVH Solutions
- Underbody Coatings



BODY ASSEMBLY

CAR BODY

- Structural Bonding
- Composite Bonding
- Panel Sealing
- Exterior Panel Bonding

COMPONENTS

- Axle Bonding
- Wheel Assembly

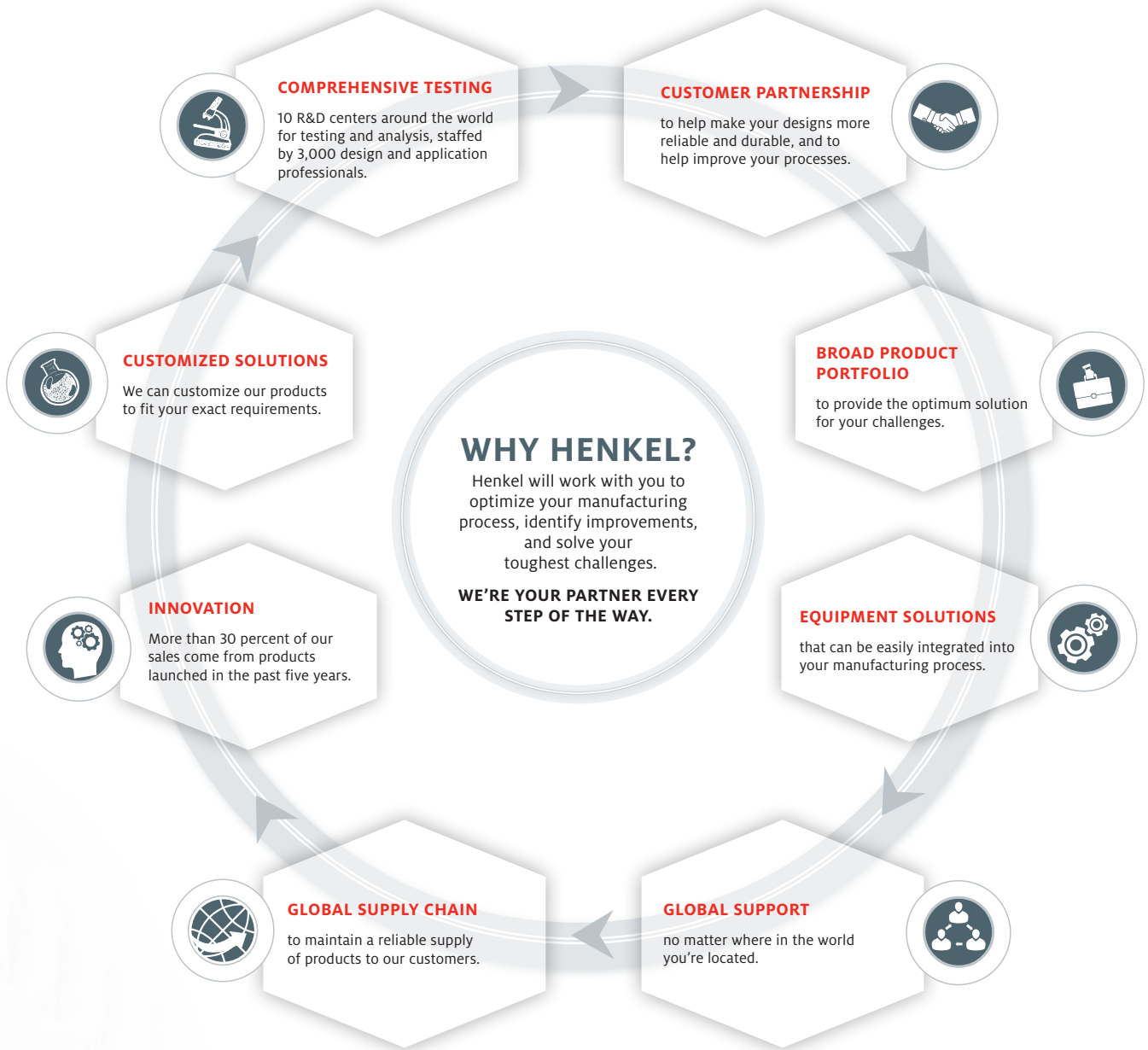

ASSEMBLY

EXTERIOR

- Window Bonding
- Window Sealing
- Anti-Slip Coatings
- Exterior Sealing
- Panel Sealing
- Panel Bonding

INTERIOR

- Floor Assembly
- Insulation Bonding
- Interior Sealing
- General Bonding
- Threadlocking
- Potting

**INSPECTION
 +
 TEST**



WORLDWIDE PRODUCTION SITES



ENGINEERING SOLUTIONS

Henkel's global network of engineering and R&D centers is staffed by 3,000 design and application professionals. We offer complete engineering services from application and design support to process optimization, as well as a full array of analytical and testing services.

CONTENTS

HENKEL – SUPPORTING YOUR INNOVATIONS, UNDERSTANDING YOUR CHALLENGES | 2

Worldwide Production Sites	4
Contents	5
Henkel Innovation Solutions	6

APPLICATIONS | 8

INDUSTRIAL CLEANING / METAL PRE-TREATMENT | 13

Industrial Cleaning and Metal Pre-Treatment	14
Operational Maintenance Cleaning	15
New Part Cleaning and Conversion Coatings	16
Remanufacturing Products	18

ASSEMBLY SOLUTIONS | 21

Structural Bonding – Panels, Walls, Roofs, Floors	22
Window Bonding and Sealing	24
Elastomeric Structural Bonding	25
Rigid Structural Bonding and Small Part Bonding	26
Elastomeric Sealing	27

NOISE, VIBRATION, HARSHNESS (NVH) AND PROTECTIVE COATINGS | 29

NVH Solutions	30
Acoustic Coatings/Pads for Noise Control	32
Anti-Slip Floor Coatings and Underbody Protective Coatings	33

MACHINERY ADHESIVES AND MAINTENANCE | 34

Thread Sealing	36
Threadlocking	37
Retaining	38
Gasketing	39
Anti-Seize Lubricants	40
Gap Filling Solutions	41

REGULATORY OVERVIEW AND TOTAL SOLUTIONS FROM HENKEL | 42

HENKEL INNOVATION SOLUTIONS

YOUR PARTNER IN THE RAIL INDUSTRY

Innovations from Henkel deliver leading high-impact solutions worldwide through a broad technology portfolio – including engineered thermal and light cure acrylic, silicone, epoxy, and polyurethane adhesives, sealants and coatings. With our history and experience in the rail industry, our experts can help you find ways to optimize your manufacturing processes and drive down costs. We can help you reduce weight, increase durability, enhance reliability, and we're continually **developing innovations** to help you succeed in the future.

LATEST INNOVATIONS INCLUDE:

LOCTITE® HYBRID SOLUTIONS

LOCTITE® general-purpose structural adhesives, powered by hybrid adhesive technology, are a breakthrough in structural bonding. They're formulated to meet the rising demands in assembly design for:

- High performance structural bonding
- Multi-surface structural bonding
- Dissimilar substrate structural bonding
- Low hazard structural adhesives

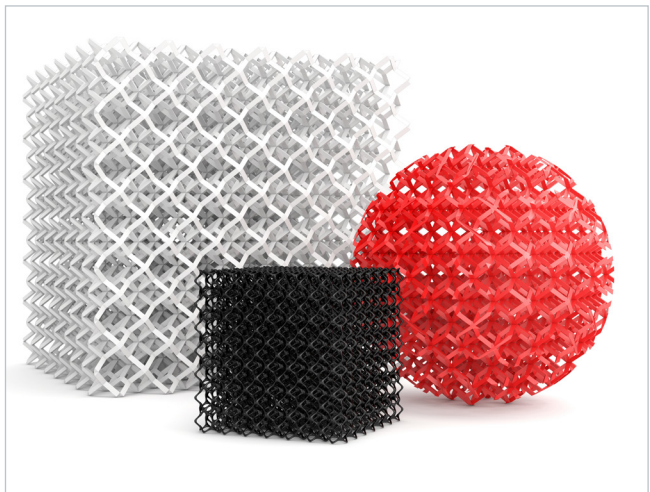

LOCTITE® 3D PRINTING SOLUTIONS

Our materials and equipment are used in post-processing applications in bonding, cleaning, surface coatings, and impregnation. Our post-processing solutions improve printed parts performance.

- Wide range of printing technologies and features including the industry's first printable silicone
- Partnership with industry leaders in printer development for ever-increasing range of capabilities
- New Advanced Customer Interaction Center in Ireland



HENKEL 3D PRINTING SOLUTIONS

3D PRINTING FOR INDUSTRIAL MANUFACTURING

To accelerate the industrial usage of 3D Printing solutions, Henkel offers a growing portfolio of high-performance adhesives and resins, along with services and equipment. This includes specialized enabling equipment for automation as well as solutions for curing, impregnation, and surface treatment in post-processing. This range of products and services has further strengthened the company's additive manufacturing ecosystem and accelerates the integration of 3D printed parts into the industrial assembly and supply chain infrastructure.

Open **LOCTITE** 3D Printing Ecosystem

Portfolio of 3D Printing materials, hardware, and software solutions

Printer Solutions

Best-in-class printer solutions from our Ecosystem Partners

Services

End-to-end services for parts production, design and engineering and post-processing

Accessory Equipment

Specialty Equipment solutions to enable more automated 3D mass production, e.g., Dispensing, Curing



Accessory Equipment

Specialty Equipment solutions to enable more automated 3D mass production, e.g., Dispensing, Curing

Customized Materials

Improved and customized materials based on broad polymer technology portfolio

APPLICATIONS

APPLICATION CATEGORIES

- 1. ANTI-GRAFFITI
- 2. ANTI-SLIP COATINGS
- 3. CABLE SEALING
- 4. COMPOSITE BONDING
- 5. FLOOR COVER BONDING
- 6. FLOOR PANEL BONDING
- 7. GENERAL SEALING
- 8. INSULATION BONDING
- 9. NVH
- 10. POTTING
- 11. PROTECTIVE COATINGS
- 12. STRUCTURAL BONDING
- 13. THREADLOCKING
- 14. WINDOW BONDING AND SEALING

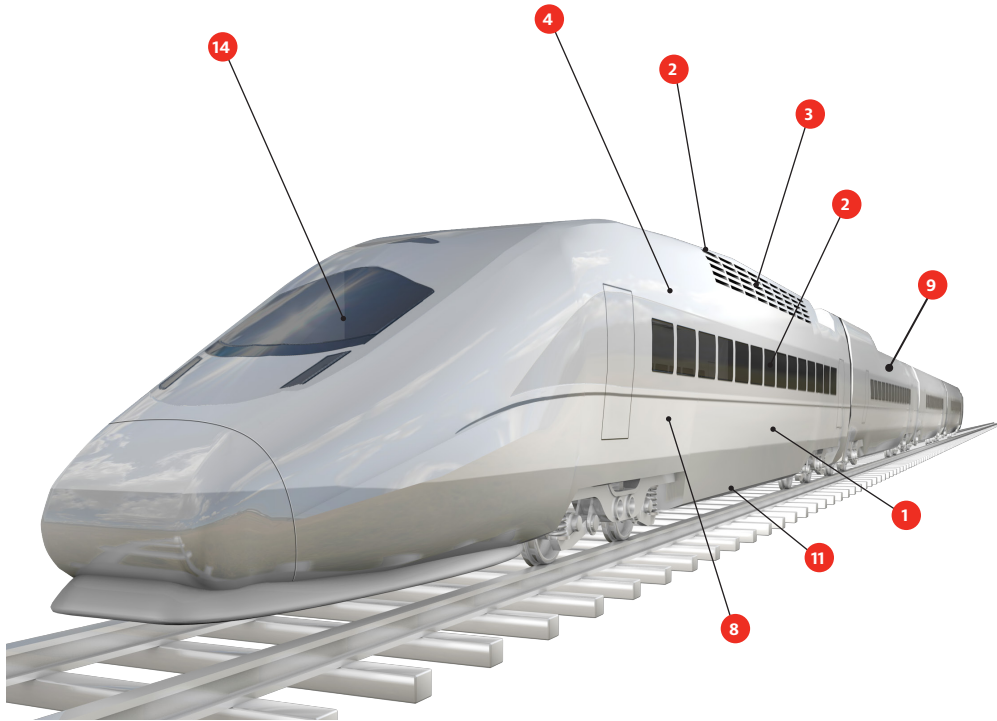

▲ HIGH SPEED TRAIN

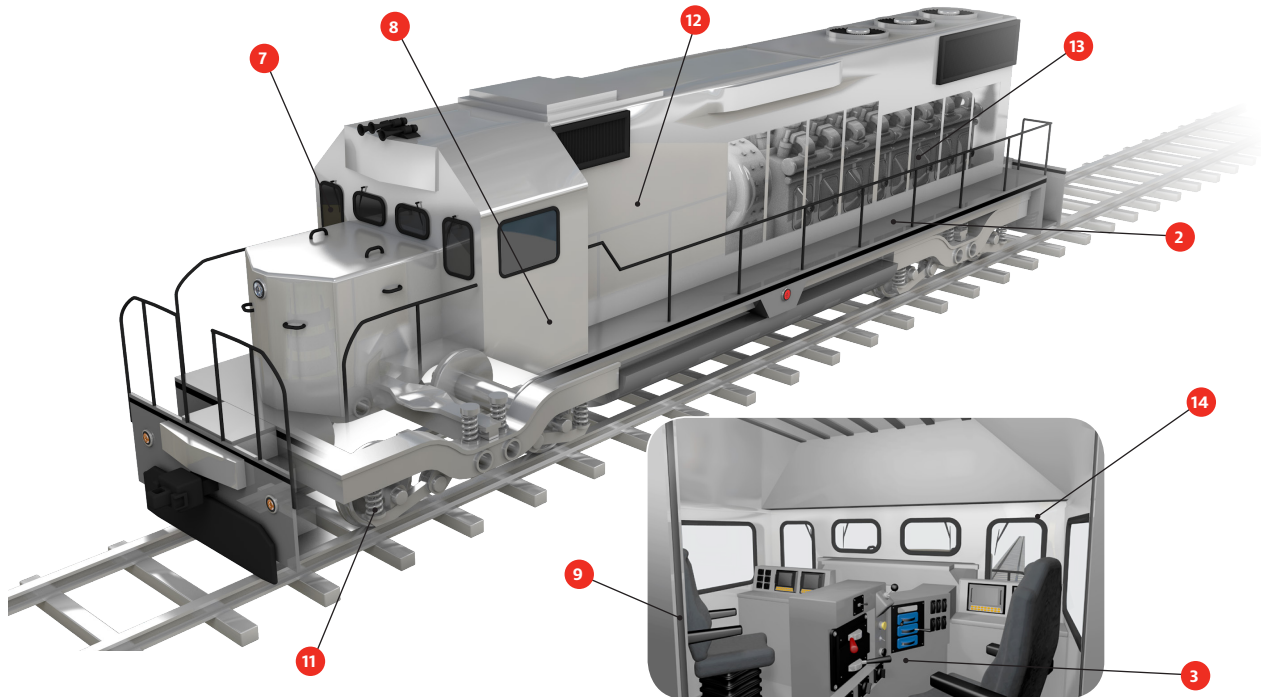

▲ LOCOMOTIVE

▲ LOCOMOTIVE CABIN

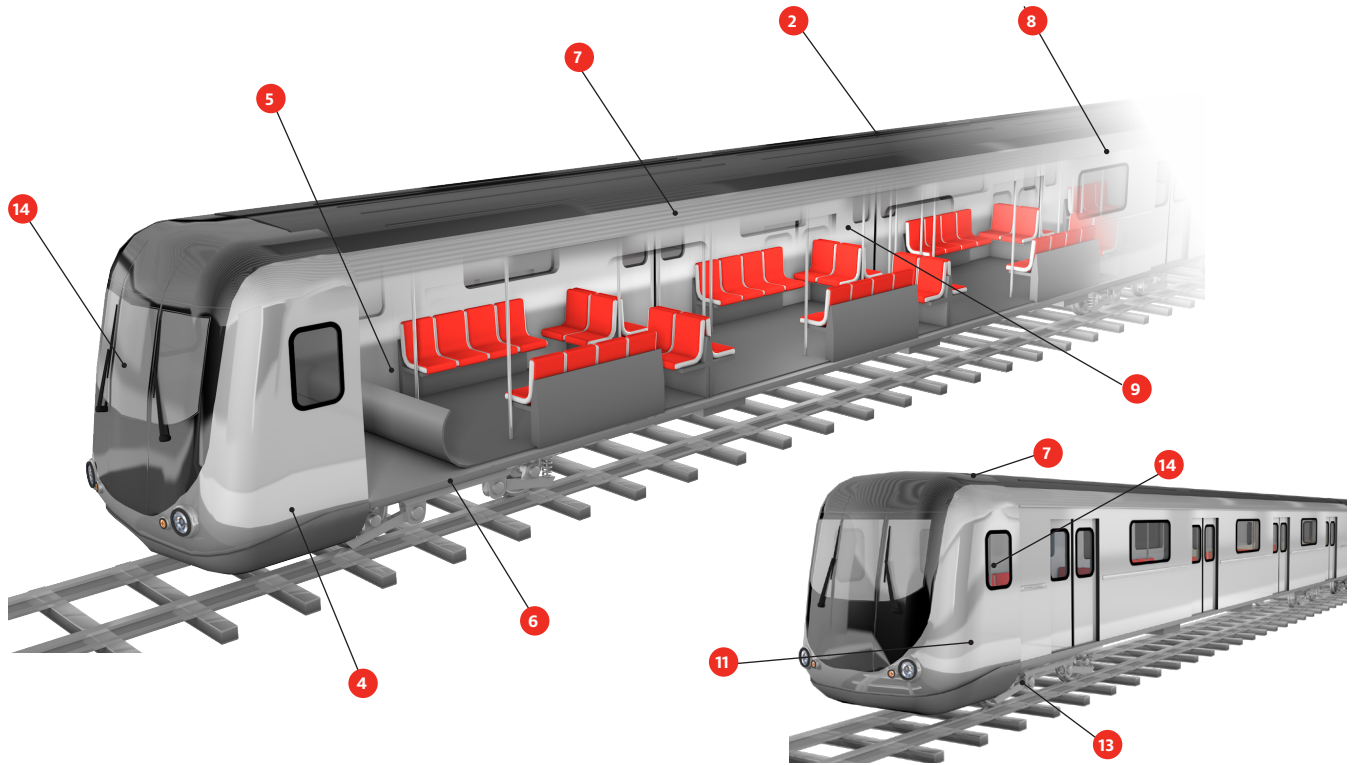

▲ SUBWAY / UNDERGROUND

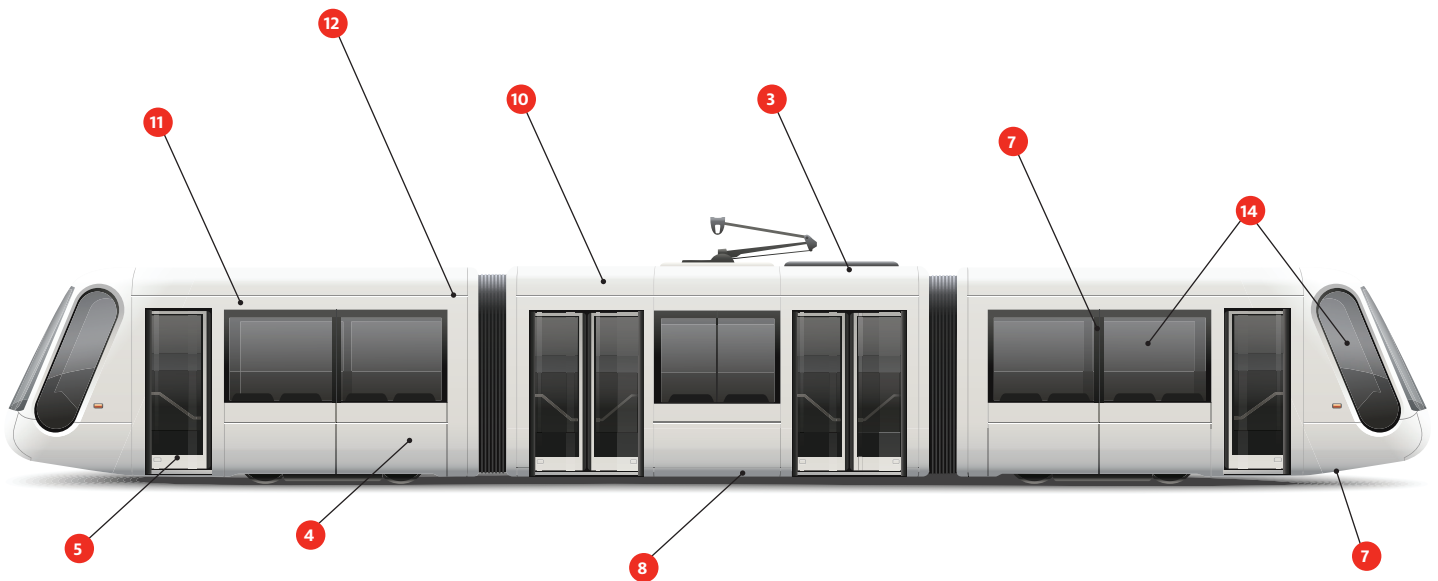

▲ TRAMWAY / STREETCAR

APPLICATIONS

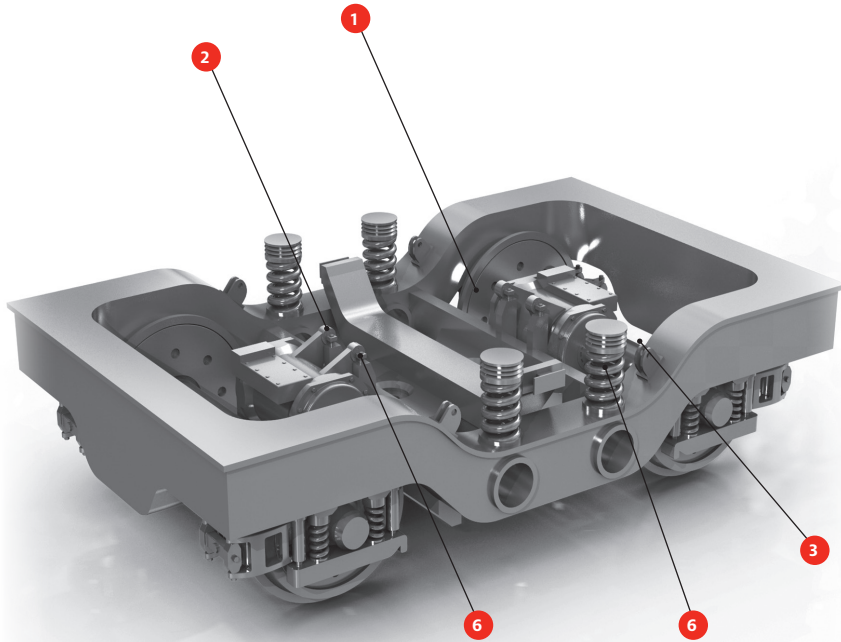

APPLICATION CATEGORIES

1. CLEANING AND METAL PRE-TREATMENT
2. THREADLOCKING, THREAD SEALING, GASKETING, RETAINING
3. PROTECTIVE COATING
4. TRAIN WASH CLEANERS
5. ANTI-SEIZE AND LUBRICANTS
6. PROTECTIVE COATINGS

▲ BOGIE

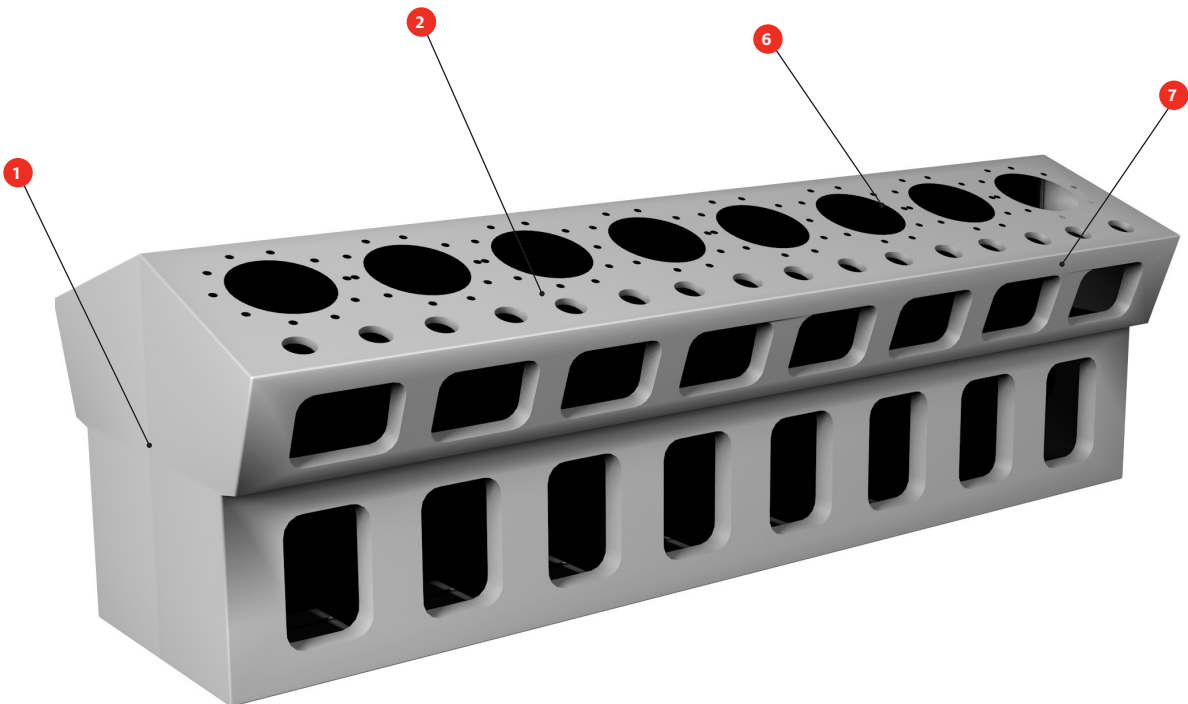

▲ DIESEL ENGINE

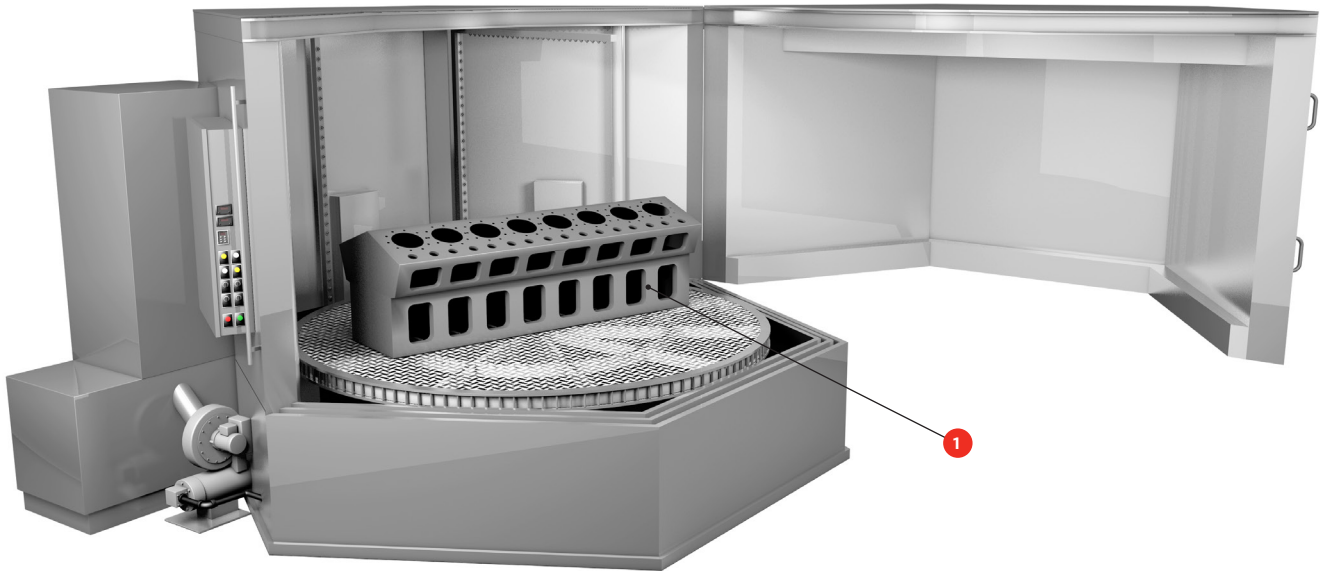

▲ REMANUFACTURING CLEANER

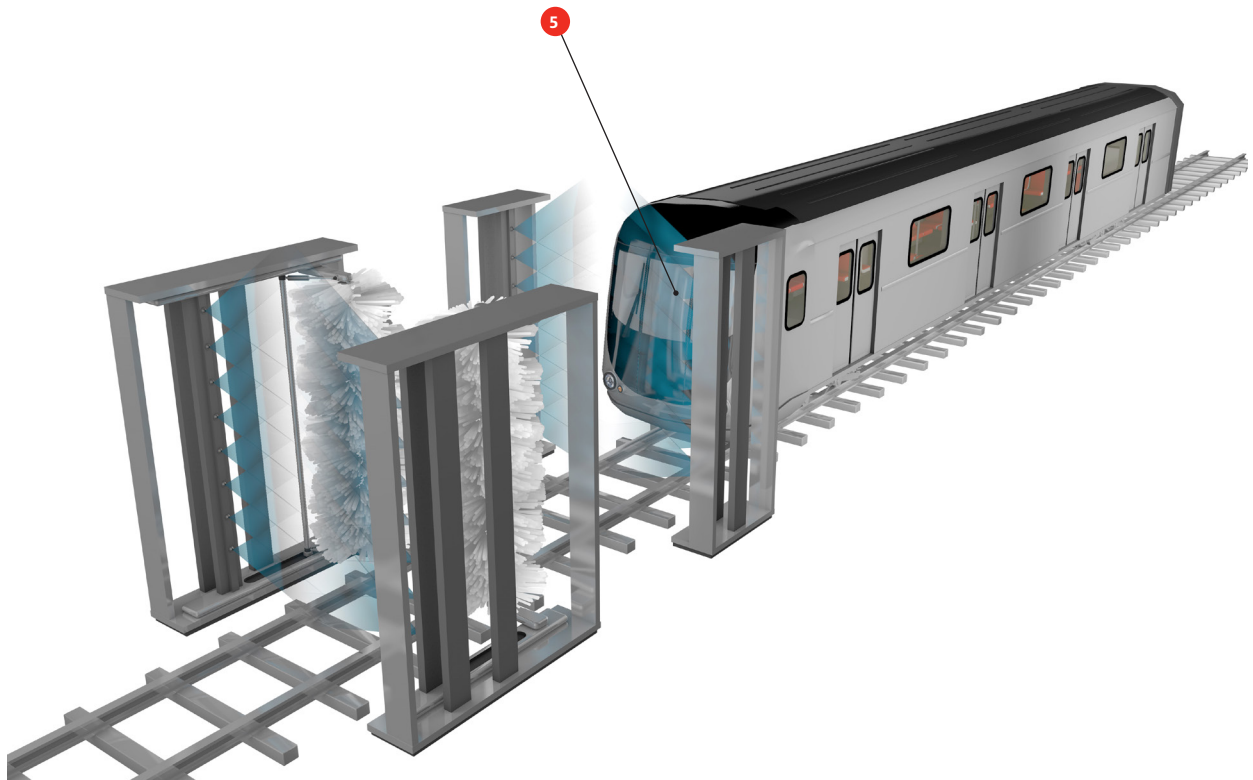

▲ VEHICLE WASH SOLUTIONS

FUNCTIONAL COATINGS

BONDERITE®

The central graphic features the text "FUNCTIONAL COATINGS" in a grey, sans-serif font, arched over a semi-circular background with a scale-like pattern. Below this, the "BONDERITE®" logo is displayed in a bold, black, italicized sans-serif font, with the "R" in "BONDERITE" highlighted in red. Two hexagonal inset images are positioned below the logo: the left one shows a worker in a blue uniform and yellow gloves using a spray gun to apply a coating to a metal surface; the right one shows a close-up of hands in work gloves working on a complex mechanical engine component.

INDUSTRIAL CLEANING / METAL PRE-TREATMENT

THE RIGHT SOLUTION FOR EVERY SURFACE CLEANING PROCESS REQUIREMENT

Henkel supplies a broad portfolio of *BONDERITE*® cleaners that help metal processors increase efficiency and lower operating costs. *BONDERITE* cleaners are simple and efficient to use while significantly improving users' environmental sustainability. A complete range of alkaline, neutral, and acidic cleaners ensures that there is a *BONDERITE* product for every cleaning requirement in four main categories: industrial and specialty, operational maintenance, new part cleaning and conversion, as well as remanufacturing.

INDUSTRIAL CLEANING AND METAL PRE-TREATMENT

BONDERITE® - INDUSTRIAL AND MAINTENANCE CLEANERS

BONDERITE® industrial and maintenance cleaners represent the highest efficiency and sustainability in industrial cleaning. Thanks to a wide range of alkaline, neutral, and acid cleaners, plus our field and laboratory services around the globe, you can be sure of the perfect solution for your cleaning needs.

WHY HENKEL *BONDERITE*

- Wide portfolio of alkaline, neutral, and acidic cleaning products that meet all application requirements
- 90 years of Henkel experience helping customers optimize their process and select the most appropriate products
- Ongoing research and product development efforts allow Henkel to be an industry leader in new technology
- Rigorous product testing in Henkel's own R&D centers
- High level product and process analysis ensuring that customers are always following best practices
- Henkel service values shared throughout the organization with customer service at their core

THE RIGHT SOLUTION FOR EVERY CLEANING

Parts cleaning and metal pre-treatment cleaning:

Neutral, acidic, and alkaline cleaners for spray and immersion for cleaning as a pre-treatment prior to subsequent surface treatments, as well as interoperational cleaners after cutting, grinding, drilling, and honing

Maintenance cleaners:

Degreasers, vehicle cleaners, descalers, graffiti removers, paint strippers, hand cleaners, floor cleaners, parts cleaners, high pressure cleaners, ultrasonic cleaners, defoamers

Services:

Field tech service, laboratory analytical services, customer-specific product development



OPERATIONAL MAINTENANCE CLEANING

MAINTENANCE CLEANERS

One of the most important aspects of keeping rail vehicles rolling is keeping them clean. Henkel offers solutions that meet the day-to-day cleaning demands of the rail industry.

EXTERIOR CLEANERS

PRODUCT NAME	AP	EU	NA	HOW TO APPLY	PH	FEATURES	USES
► BONDERITE C-MC 3000	✓	✓	✓	Spray, Brush	Alkaline	Excellent general-purpose cleaner; foams to stay on vertical surfaces. Applied at room temperature up to 80°C.	Heavy oil, grease, dust, carbon, flash rust
<i>BONDERITE C-MC 12300</i>	✓	✓		Spray, Brush	Neutral	Universal liquid cleaner for interior surfaces. Good for soil removal, and has small foaming effect. Ambient temperature application.	Dust and greasy indoor dirt
► BONDERITE C-MC 30112		✓		Spray	Alkaline	Lower pH than competition allows for longer exposure without affecting paint job. Sticks to surfaces to better dissolve soils.	Insect removal from paint and windscreens
<i>BONDERITE C-MC ACD-1166</i>		✓		Spray, Brush	Acid	Acidic cleaner for automatic applications. Free of oxalic acid; works with hard water.	Iron and copper oxides, brake dust, mineral soiled, light organic dirt
<i>BONDERITE C-MC GEL-7</i>		✓		Brush, Wipe	Alkaline	Heavy-duty cleaner. Applicable on vertical and upside down surfaces.	Bogie cleaning
<i>BONDERITE C-MC N DB</i>		✓		Spray, Brush	Neutral	Safe and easy-to-use neutral cleaner. Suitable for automatic cleaning lines. Applied at room temperature (up to 50°C).	Oil, brake dust, carbon, environmental dirt

GRAFFITI REMOVERS

PRODUCT NAME	AP	EU	NA	HOW TO APPLY	PH	FEATURES
► BONDERITE C-MC 245		✓		Brush, Wipe	Alkaline	Designed to completely remove graffiti ink shadow after cleaning processes.
► BONDERITE C-MC 400	✓	✓		Brush	Acid	Removal of external graffiti, available in 3 different viscosities, designed for manual cleaning, should be applied above 5°C.
<i>BONDERITE S-ST 1302</i>		✓		Spray, Brush	Alkaline	For removal of interior graffiti, great EH&S ratings, requires room temperature application.

PAINT GUN CLEANERS

PRODUCT NAME	AP	EU	NA	HOW TO APPLY	PH	FEATURES
<i>BONDERITE C-MC 21130</i>	✓	✓		Spray, Immersion	N/A	Paint gun cleaner for solvent-based and water-based paints.
<i>BONDERITE C-S0-283</i>			✓	Spray, Immersion	N/A	Organic solvent paint gun cleaner for cleaning solvent-borne paint application equipment and metal surfaces.

PART CLEANERS

PRODUCT NAME	AP	EU	NA	HOW TO APPLY	PH	FEATURES
<i>BONDERITE C-MC 90014</i>	✓	✓		Manual	Alkaline	Parts cleaner to replace solvents.

► **Product highlighted** = GO TO product

NEW PART CLEANING AND CONVERSION COATINGS

PRODUCTS FOR METAL PRE-TREATMENT – CONVERSION COATING CLEANERS AND CONVERSION COATINGS

BONDERITE® offers conversion coating cleaners and conversion coatings that can increase corrosion protection, adhesion, and performance of a substrate.

METAL PRE-TREATMENT: CONVERSION COATING CLEANERS

PRODUCT NAME	AP	EU	NA	HOW TO APPLY	PH	FEATURES
BONDERITE C-AD 0470	✓	✓		Immersion	N/A	Cleaning booster for immersion processes
BONDERITE C-AD 5003	✓	✓		Spray	N/A	Cleaning booster for spray processes
► BONDERITE C-AK 1574	✓	✓	✓	Spray, Immersion	Alkaline	Multi-metal cleaner, low foam
BONDERITE C-S0 263			✓	Pre-Saturated Wipes	N/A	Manual Application

METAL PRE-TREATMENT: CONVERSION COATINGS

PRODUCT NAME	AP	EU	NA	HOW TO APPLY	PH	FEATURES	METAL			PAINT		
							STEEL	GALVANIZED STEEL	ALUMINUM	POWDER COATING	WET COAT	E-COATING
BONDERITE M-CR 65000		✓	✓	Spray, Immersion	Acid	Steel, galvanized steel, aluminum, based on trivalent chromium with mil spec approval	✓	✓	✓	✓	✓	✓
BONDERITE M-FE 700			✓	Spray, Immersion	Acid	Iron phosphate cleaner and coating for steel, low temperature cure 30°C, heavy-duty	✓	✓	✓			
BONDERITE M-FE-500LT			✓	Spray, Immersion	Acid	Iron phosphate cleaner and coating for steel, low temperature cure 30°C, light-to-medium-duty	✓					
BONDERITE M-NT 1200	✓	✓	✓	Spray	Acid	Phosphate-free substitute for zinc phosphating for steel, galvanized steel, or aluminum 2-component	✓	✓	✓	✓	✓	✓
► BONDERITE M-NT 1455-W	✓	✓	✓	Pre-Saturated Wipes	Acid	Manual application for multi-metals, chrome-free	✓	✓	✓			
BONDERITE M-NT 1800	✓	✓	✓	Immersion	Acid	Phosphate-free substitute for zinc phosphating for steel, galvanized steel, or aluminum 2-component	✓	✓	✓	✓	✓	✓
BONDERITE M-NT 2			✓	Spray, Immersion	Acid	Offers improved corrosion resistance and can be used for steel, galvanized steel, and aluminum 1-component	✓	✓	✓	✓	✓	✓
BONDERITE M-NT 30002		✓		Spray, Immersion	Acid	Used on steel, galvanized steel, and aluminum based on trivalent chromium	✓	✓	✓	✓	✓	✓
BONDERITE M-NT 40043		✓		Spray, Immersion	Acid	Cleaner-coater, zirconium-based chemical conversion for steel, galvanized steel, and aluminum	✓	✓	✓	✓	✓	
BONDERITE M-NT 5700-W	✓		✓	Pre-Saturated Wipes	Acid	Manual application for aluminum only, passes AAMA specs, chrome-free			✓			
BONDERITE M-NT 701/M-NT 41042		✓	✓	Spray, Immersion	Acid	Cleaner-coater	✓	✓	✓	✓	✓	
BONDERITE M-PP 866	✓	✓	✓	Immersion	Acid	Flexible PVDC-coating, light-to-medium-duty interior applications, cure before top coating	✓			✓	✓	
BONDERITE M-PP 930	✓	✓	✓	Immersion	Acid	Hard epoxy-acrylic coating, ideal for harsh environments and tubular structures, can be co-cured with paint	✓				✓	
► BONDERITE M-ZN 3410			✓	Spray, Immersion	Acid	Robust, easy-to-use, recommended GO TO product	✓	✓	✓	✓	✓	✓
BONDERITE M-ZN 952/958	✓	✓	✓	Spray, Immersion	Acid	For creating tricationic zinc phosphate coating; compatible with most metals	✓	✓	✓	✓	✓	✓

► Product highlighted = GO TO product

PRODUCTS FOR DERUSTING AND DESCALING

Incoming materials in rail often have mill scale and require removal of flash rust. Henkel offers derusting and descaling products that will remove soil, rust, and scale prior to conversion coatings – ultimately optimizing cost and labor.

DERUSTING AND DESCALING PRODUCTS

PRODUCT NAME	AP	EU	NA	HOW TO APPLY	PH	FEATURES
<i>BONDERITE C-AK 359</i>	✓	✓		Spray	Alkaline	Multi-metal degreaser; mild foaming
<i>BONDERITE C-AK 5800</i>	✓	✓	✓	Spray	Alkaline	Cleaner for steel and plastic
<i>BONDERITE C-AK LNS</i>	✓		✓	Spraying or High Pressure	Alkaline	Cleaner for aluminum
▶ <i>BONDERITE C-IC 172</i>	✓	✓	✓	Derusting and Descaling (Prior to Conversion Coatings)	Acid	Phosphoric acid pickling product for steel
<i>BONDERITE C-IC 182 C</i>			✓	Spray, Immersion	Acid	Inhibited phosphoric acid pickling product for steel
<i>BONDERITE C-IC NP 7300</i>			✓	Spray, Immersion	Acid	Sulphuric acid pickling product for steel
<i>BONDERITE C-MC 80</i>	✓	✓		Spraying or High Pressure	Alkaline	Cleaner for steel and non-ferrous metals (light metals should be tested for compatibility)
▶ <i>BONDERITE C-NE 20</i>	✓	✓	✓	Immersion	Neutral	Universal neutral degreaser
▶ <i>BONDERITE C-NE 5088</i>	✓	✓	✓	Spray	Neutral	Heavy-duty neutral degreaser; very robust chemistry; solvent-free
▶ <i>LOCTITE SF 7063</i>	✓	✓		Wiping, Immersion	Neutral	Maintenance shop use
▶ <i>LOCTITE SF 7070</i>	✓	✓		Wiping, Immersion	Neutral	Maintenance shop use

▶ **Product highlighted** = GO TO product

TEMPORARY CORROSION PROTECTION

Rust preventatives should be used in any area with more than 40% humidity in order to prevent metals from flash rusting.

TEMPORARY CORROSION PROTECTION PRODUCTS

PRODUCT NAME	AP	EU	NA	HOW TO APPLY	PH	FEATURES
<i>BONDERITE S-FN 7400</i>	✓	✓		Spray, Immersion	Alkaline	Steel and cast iron, can be painted over; 1 day of protection
<i>BONDERITE C-NE 3300</i>	✓	✓	✓	Spray, Immersion	Neutral	Multi-metal, protection and cleaner, 1-3 days of protection
<i>BONDERITE S-PR 6776</i>		✓		Spray, Immersion	Neutral	Multi-metal 1-6 weeks of protection
<i>BONDERITE S-PR 3</i>	✓	✓		Spray, Immersion	N/A	Steel and cast iron, oil-based product, 3-6 months of protection
<i>BONDERITE L-GP 5800</i>	✓		✓	Spray, Immersion	Alkaline	All metals, water-based emulsion, 1-6 weeks of protection
<i>BONDERITE L-GP 4141</i>			✓	Spray, Immersion	N/A	Steel and cast iron protection, oil-based, 3-6 months of protection
<i>BONDERITE S-FN 503</i>			✓	Spray, Immersion	Alkaline	Steel and cast iron protection, can be painted over; 1 day of protection
<i>BONDERITE O-PC 100</i>	✓	✓		Spray, Immersion	N/A	Water-based PVDC-coating
<i>BONDERITE O-PC 700</i>	✓	✓		Spray, Immersion	N/A	Water-based Alkyd-coating
<i>BONDERITE O-PC 528 RFU</i>		✓		Spray, Immersion	N/A	Solvent-based PVB-epoxy phenolic primer

REMANUFACTURING PRODUCTS

PRODUCTS FOR REMANUFACTURING

Henkel offers degreasers, derusting/descaling products, deoxidizing and decarbonizing products, cleaners and paint strippers – all formulated for remanufacturing. Henkel's chemistries are formulated to be robust, strong, and aggressive enough to cut through heavy grease, oils, and paint coatings.

DEGREASING PRODUCTS

PRODUCT NAME	AP	EU	NA	HOW TO APPLY	PH	FEATURES	USES			
							STEEL	ALUMINUM	GALVANIZED	PLASTICS
► BONDERITE® C-AK 1574 MRO		✓	✓	Immersion	Alkaline	One-step degreasing, derusting, and paint stripping of steel	✓			
BONDERITE C-AK 5520	✓	✓		Spray	Alkaline	Steel and nonferrous metals degreasing	✓	✓	✓	
► BONDERITE C-AK RM-21	✓		✓	Immersion	Alkaline	One-step degreasing, derusting, and paint stripping of steel	✓			
BONDERITE C-MC 3000		✓		Spray and foam, Manual	Alkaline	Steel and plastic degreasing	✓			✓
BONDERITE C-MC 35050			✓	Spray wand cleaner	Alkaline	For large applications such as vessels, machines, and tanks	✓			
BONDERITE C-NE 175		✓		Immersion, Spray	Neutral	Multi-metal and plastic degreasing	✓	✓	✓	✓
BONDERITE C-NE 5175			✓	Immersion, Spray	Neutral	Contains some rust preventative	✓	✓	✓	✓
BONDERITE C-NE 5220-1		✓	✓	Spray (low pressure)	Neutral	Multi-metal degreasing	✓	✓	✓	✓
BONDERITE C-SO 283			✓	Hand (wipe)	Neutral	Fast drying, blended solvent. Verify plastic compatibility before use.	✓	✓	✓	✓

STEEL DERUSTING/DESCALING PRODUCTS

PRODUCT NAME	AP	EU	NA	HOW TO APPLY	PH	FEATURES
BONDERITE C-AK 1574 MRO		✓	✓	Immersion	Alkaline	One-step degreasing, derusting, and paint stripping
BONDERITE C-AK 338	✓		✓	Immersion	Alkaline	Powdered, use on steel, galvanized steel, and aluminum
BONDERITE C-AK RM-21	✓		✓	Immersion	Alkaline	One-step degreasing, derusting, and paint stripping
BONDERITE C-IC 182C			✓	Spray, Immersion	Acid	Phosphoric acid pickling for steel
BONDERITE C-IC 3502		✓		Immersion	Acid	Pickling and derusting of iron and steel
BONDERITE C-IC NP 7300			✓	Immersion	Acid	Sulphuric acid, phosphate-free pickling for steel
BONDERITE C-MC LAVOXYD			✓	Spray, Immersion, Manual	Acid	Exterior train and tanker wash
BONDERITE C-NE 90200	✓	X	✓	Immersion, spray	Neutral	Neutral and phosphate-free derusting

ALUMINUM CLEANING AND DEOXIDIZING PRODUCTS

PRODUCT NAME	AP	EU	NA	HOW TO APPLY	PH	FEATURES
BONDERITE C-IC 1721			✓	Spray, immersion	Acid	Aluminum only
BONDERITE C-IC 3012			✓	Immersion	Acid	Cleaner and paint stripper in one (Use with S-ST 3012MM)
BONDERITE C-IC 457			✓	Spray, immersion	Acid	Aluminum only
► BONDERITE C-MC 11110		✓		Immersion	Acid	Multi-metal including aluminum
BONDERITE S-ST 3012MM			✓	Immersion	Acid	Cleaner and paint stripper in one (Use with C-IC 3012)
► BONDERITE S-ST 6776 LO AERO	✓	✓	✓	Immersion	N/A	Multi-metal cleaner (includes aluminum) with paint stripping ability

DECARBONIZING PRODUCTS

PRODUCT NAME	AP	EU	NA	HOW TO APPLY	PH	FEATURES	USES		
							STEEL	ALUMINUM	GALVANIZED
► <i>BONDERITE C-AK 1574 MRO</i>		✓		Immersion	Alkaline	Strong alkaline degreasing, derusting and decarbonizing of steel	✓		
<i>BONDERITE C-AK 5948 DPM THICK</i>		✓	✓	Brush or spray	Alkaline	Clings to surfaces to degrease aluminum without harming paints		✓	
<i>BONDERITE C-AK 9045-6 AERO</i>		✓	✓	Immersion	Alkaline	Water-based carbon remover		✓	
► <i>BONDERITE C-AK RM-21</i>	✓		✓	Immersion	Alkaline	Degreasing, derusting and paint stripping	✓		
<i>BONDERITE C-MC GEL-7</i>		✓		Brush or spray	Alkaline	Decarbonizing of aluminum		✓	

PAINT STRIPPING PRODUCTS

PRODUCT NAME	AP	EU	NA	HOW TO APPLY	PH	FEATURES	USES		
							STEEL	ALUMINUM	GALVANIZED
<i>BONDERITE C-AK RM21</i>	✓		✓	Immersion	Alkaline	Heavy-duty degreaser and rust remover for reman	✓		
<i>BONDERITE S-AD 201</i>		✓		Immersion	N/A	Strips paints (including e-coats) from all substrates, product combined with <i>BONDERITE S-ST 99 A</i>		✓	✓
<i>BONDERITE S-AD-18</i>			✓	Spray	N/A	Additive to boost performance of paint strippers, multi-metal compatibility	✓	✓	✓
<i>BONDERITE S-AD-21</i>			✓	Immersion	N/A	Additive to boost performance of paint strippers, multi-metal compatibility	✓	✓	✓
<i>BONDERITE S-ST 3000</i>			✓	Spray, immersion	Alkaline	Removes all types of paints, provides etch resistance, low odor		✓	
<i>BONDERITE S-ST 301</i>			✓	Immersion	Alkaline	Paint stripper safe for aluminum wheels	✓	✓	✓
<i>BONDERITE S-ST 3012MM</i>			✓	Immersion	Acid	Heavy-duty paint stripper for reman, used with C-IC 3012		✓	
<i>BONDERITE S-ST 65</i>		✓		Spray, immersion	Alkaline	Strips paints (including e-coats) and powder coatings	✓		
► <i>BONDERITE S-ST 6776 THIN</i>		✓	✓	Immersion	Acid	Highly chemically resistant polyurethane, removes polyurethane paint	✓	✓	✓
<i>BONDERITE S-ST 6776 LO AERO</i>	✓	✓	✓	Hand brushing	Acid	Highly chemically resistant polyurethane, removes polyurethane paint	✓	✓	✓
<i>BONDERITE S-ST 9210</i>		✓		Spray, immersion	Alkaline	Highly alkaline paint stripper with hot working temperature	✓		
<i>BONDERITE S-ST 99 A</i>		✓		Immersion	N/A	Strips paints (including e-coats) from all substrates, product combined with <i>BONDERITE S-AD 201</i>		✓	✓
<i>BONDERITE S-ST HOT 50</i>			✓	Immersion	Alkaline	Removes all types of paints	✓		



ASSEMBLY SOLUTIONS

FASTER AND LOWER-COST ASSEMBLY WITH MORE DESIGN CHOICES

From structural bonding to seam sealing and window glazing, we provide a complete range of technologies that allow you to reduce or replace traditional mechanical fastening and sealing methods in a variety of assembly applications.

Bonded joints eliminate the cost of mechanical fasteners and welds, and allow dissimilar materials to be joined. These bonded joints distribute load more evenly allowing lighter gauge materials with tighter tolerances to be used. Replacing welds, rivets, and bolts also helps manufacturers eliminate leaks and reduce warranty claims. The end result is stronger, lighter, more economical vehicles with increased performance.

STRUCTURAL BONDING – PANELS, WALLS, ROOFS, FLOORS

FROM WELD AND FASTENER REDUCTION TO ASSEMBLY OF DISSIMILAR SUBSTRATES

- ▶ FOR USE BETWEEN FLEXIBLE SHEET METALS, RIGID CASTINGS/ EXTRUSIONS, AND/OR COMPOSITE/PLASTIC MATERIALS

Primarily designed to replace welds, rivets, and other mechanical fasteners in the body, paint or trim shops, our wide range of high strength structural adhesives enable the assembly of non-metallic substrates and open new perspectives of lightweight designs.

The distributed load an adhesive provides versus the stress concentrations of mechanical fastening allows thinner, lower weight panels to be implemented – ultimately reducing weight.

WHY USE A STRUCTURAL ADHESIVE?

- Increase strength
- Seal, bond, and protect in one step
- Noise, vibration, harshness (NVH) damping
- Prevent corrosion
- Improve aesthetics
- Simplify designs
- Improve part performance
- Join dissimilar substrates
- Distribute stress evenly
- Reduce assembly time
- Reduce water leaks

WHERE TO USE A STRUCTURAL ADHESIVE:

- Skin to frame assembly
- Door and panel stiffener attachment
- Bracket attachment
- Plastic and composite components
- Aluminum and stainless components

DIFFERENT JOINT METHODS LEAD TO DIFFERENT STRESS DISTRIBUTION:

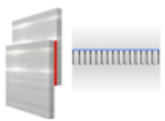

Bonding

- Even stress distribution
- Distribution over a large area

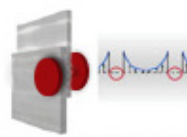

Spot Welding

- Produces read-through, (dimples on surface)
- Very irregular stress distribution
- Stress concentration at holes

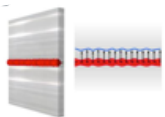

Welding

- Uneven stress distribution
- Concentration within small welding line
- Heat distorting of substrate

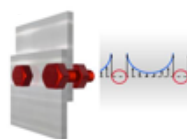

Huck Bolts / Rivets / Bolting

- Very irregular stress distribution
- Stress concentration at holes
- Water ingress route

STRUCTURAL ADHESIVE SOLUTIONS

TECHNOLOGY	PRIMARY USES	ADVANTAGES	CONSIDERATIONS
Silane Modified Polymers (SMPs)	For plastic and treated/painted sheet metal where fatigue resistance, weather resistance, and elastic bonding are needed	<ul style="list-style-type: none"> • Primerless adhesion to most substrates • Excellent anti-flutter material • Great UV stability • No solvent, isocyanates or silicone • Good paintability after cure up to 3 days 	<ul style="list-style-type: none"> • Poor adhesion on oily metal • Maximum temperature resistance • Low cohesive strength • Slow fixture and cure speed • Moisture-sensitive
Polyurethanes (PU)	For plastic and treated/painted sheet metal parts where fatigue resistance and elastic bonding are needed	<ul style="list-style-type: none"> • Excellent flexibility • Great for noise and vibration reduction • Great adhesion on plastics and painted metal • Great on dissimilar materials • Excellent paintability after cure up to 7 days 	<ul style="list-style-type: none"> • Limited temperature resistance (1 hr. at 140°C/284°F) • Poor adhesion to bare and oily metal • Poor corrosion resistance • Contains isocyanates • Moisture-sensitive before cure • Multi-step surface preparation
Two-Part (2k) Acrylics	For a wide range of substrates including oily metal in body and trim shops where high cleavage and strength are required	<ul style="list-style-type: none"> • Excellent adhesion on plastic and metal • High peel and impact resistance • Excellent oily surface adhesion • Good corrosion resistance • High heat resistance (30 minutes at 200°C/428°F) 	<ul style="list-style-type: none"> • Requires mixing and/or fixturing • Refrigerated storage • Strong odor (MMA) Modified Methacrylate Acrylics • Not weld-through capable (flammable) • May create read-through on thin metals
Two-Part (2k) Epoxies	For metal in body shops where high cleavage and strength are required	<ul style="list-style-type: none"> • High shear and impact strength on metal • Oily surface adhesion (heat cure) • Excellent moisture resistance • Excellent heat resistance (up to 1 hour at 220°C/428°F) • Weld-through compatible 	<ul style="list-style-type: none"> • Slow fixture/cure times (2k) • Requires mixing and/or fixturing during cure • Poor elongation and damping • Below average oil tolerance • Poor adhesion to plastics
Two-Step Acrylics	For a wide range of substrates in body and paint shops where rapid on-demand fixturing is needed	<ul style="list-style-type: none"> • No mixing, cure on-demand • Good corrosion resistance • High strength on wide range of substrates • Light oily surface adhesion • High heat resistance (30 minutes at 200°C/428°F) 	<ul style="list-style-type: none"> • Activator may contain solvents • Resin has moderate odor • Low cure-through depth, ~1 mm • Fillets remain uncured • Not weld-through capable
One-Part (1k) Epoxy	For sheet metal in body and paint shop applications as a flexible anti-flutter material as well as primary structure bonding to replace welds and other joining methods	<ul style="list-style-type: none"> • Wide range of expansions (0 to >1000%) • Good adhesion on oily metal • Weld-through capable • Unlimited open time; weld-through capable • High toughness and peel strength • Excellent washout resistance 	<ul style="list-style-type: none"> • Limited to hidden/non-visible joints • Requires heat to cure • Can be induction or thermal cured

WINDOWS BONDING AND SEALING

BONDING AND SEALING WINDOWS / ELASTOMERIC BONDING

Designed to bond windscreens and side windows to the train body, our wide range of window bonding adhesives simplifies and improves the assembly process while improving torsional stiffness and vehicle safety.

WHY USE AN ELASTOMERIC STRUCTURAL PRODUCT?

- Seal in/out heat, liquids, solids, and gases (e.g., moisture, dirt, and exhaust)
- Improve safety, aesthetics, and drag
- Airtight seal results in improved noise, vibration, and harshness (NVH) enhancements
- Higher strength for increased glass retention

WHERE TO USE AN ELASTOMERIC STRUCTURAL PRODUCT:

- Bonding and sealing windscreens
- Bonding of floor panels
- Sealing between panes of glass
- Stationary windows and sunroofs
- Backfilling large gaps and voids
- Bonding headliner and upholstery

TYPES OF ELASTOMERIC STRUCTURAL PRODUCTS:

Moisture Curing Elastomeric Products Include:	Controlled Curing Elastomeric Products Include:	Primerless Elastomeric Products Include:
<ul style="list-style-type: none"> • High modulus single-component, PU-based adhesives • Low modulus single-component, SMP-based adhesives 	<ul style="list-style-type: none"> • Accelerated single-component, PU-and-SMP-based adhesives • Two-part (2k), SMP-based, elastomeric adhesives 	<ul style="list-style-type: none"> • Single-component, moisture-cure or accelerated PU-and SMP-based adhesives • Two-part (2k), SMP-based elastomeric adhesives • Dual-component, SMP-based adhesives

TYPICAL WINDSCREEN INSTALLATION PROCESS

► HOW TO USE WINDOW BONDING PRODUCTS

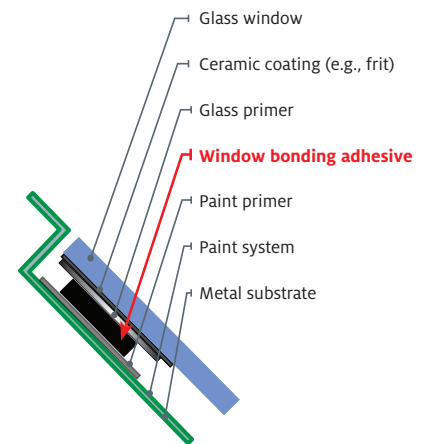
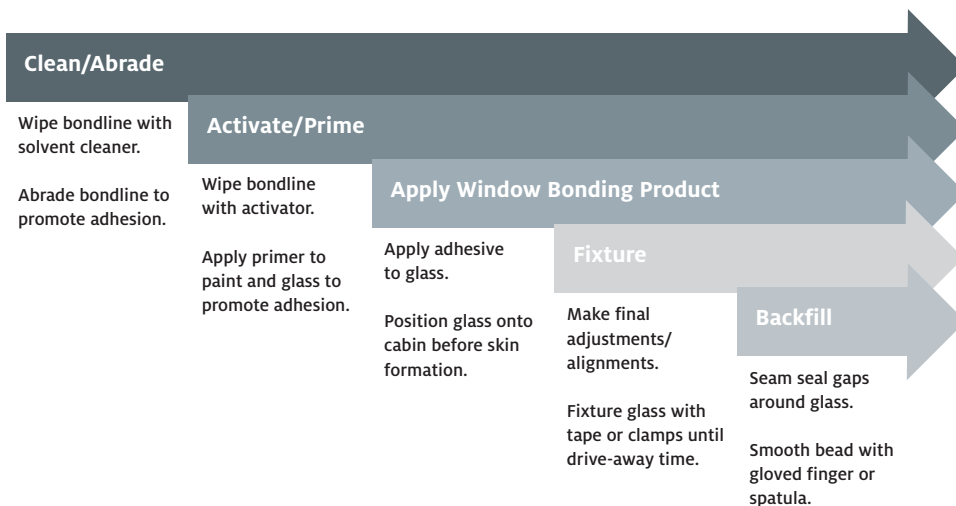

CROSS SECTION OF TRADITIONAL WINDOW BONDING APPLICATION

ELASTOMERIC STRUCTURAL BONDING

ELASTOMERIC STRUCTURAL BONDING ADHESIVES

Elastomeric structural bonding adhesives are widely utilized to bond front windscreens and side glass to rail vehicles. These materials eliminate the need for rubber seals, leading to improved vehicle appearance. Elastomeric adhesives are also ideal for large panel bonding of specialty vehicle and rail structures. While increasing aesthetics, lightweighting the vehicle, and still maintaining structural strength, elastomeric adhesives also maintain elasticity for improvement of torsional stiffness and accommodation of differential thermal expansion.

ADHESIVE FEATURES

- Offer high elongation to accommodate movement due to thermal expansion and contraction
- Allow for high dispense rates for large parts
- One-and-two-part adhesives available
- When accelerated, will cure large gaps independent of atmospheric moisture

PRODUCT	CHEMISTRY	AP	EU	NA	COLOR	MIX RATIO	OPEN TIME (MIN.)	CURE TIME (HOURS)	TENSILE STRENGTH MPA	SHEAR STRENGTH STEEL - MPA	ELONGATION %	HARDNESS SHORE A	DESCRIPTION
<i>LOCTITE</i> [®] UK UK 8103 B15 / UK 5400	Polyurethane	✓	✓		Beige	3.9:1 by volume	15	72	N/A	>6	N/A		Panel lamination adhesive
► <i>TEROSON</i> 939 FR	MS Polymer	✓	✓	✓	Black, Grey	1k	10	24	3.0	N/A	180	55	Flame-resistant, adhesive and sealant, DIN 6701 data available
<i>TEROSON</i> 939 FR / 9371 B	MS Polymer		✓		Black, Grey	Static Mix (10:1)	10	24	3.0	N/A	180	55	Greater depth of cure and cure independent of atmospheric moisture
► <i>TEROSON</i> MS 9320 SF	MS Polymer		✓	✓	Gray, Black	1k	10	24	N/A	N/A	N/A	30	Excellent for lamination and sealing
<i>TEROSON</i> MS 937	MS Polymer	✓	✓		White, Black, Grey	1k	15	24	3.0	N/A	220	50	General-purpose bonding, longer open time to allow part alignment faster setting than MS 939
<i>TEROSON</i> MS 939	MS Polymer	✓	✓			1k	10	24	3.0	N/A	250	55	General-purpose bonding adhesive with very good environmental resistance
<i>TEROSON</i> PU 8590 N/M	Polyurethane	✓			Black	1k	30	27	8.0	6.0	450	65	General-purpose adhesive; Exclusive to India
<i>TEROSON</i> PU 8590 UHV BUS	Polyurethane		✓		Black	1k	25	24	8.0	5	450	60	Good UV resistance, smooths well, requires primer, DIN 6701
<i>TEROSON</i> PU 8630 HMLC	Polyurethane		✓		Black	Static Mix (1:1)	25	24	9.5	4.5	370	60	Two-part window bonder, warm-applied, long open time, rapid fixture
<i>TEROSON</i> PU 8900 LV	Polyurethane		✓		Black	1k	20	24	8.0	5	400	55	Primerless designed for bonding, DIN 6701 data available
<i>TEROSON</i> VR 5000	Solvent-based SBR	✓			Beige	Pre-mixed	10	0	N/A	N/A	N/A	N/A	N/A
<i>TEROSON</i> MS 9399	MS Polymer		✓		White, Black, Grey	Static Mix (1:1)	30	24	3.0	2	150	55	High cure-through depth, DIN 6701 data available

► Product highlighted = GO TO product

RIGID STRUCTURAL BONDING AND SMALL PART BONDING

RIGID STRUCTURAL BONDING ADHESIVES

Rigid bonders can be used for constant fixturing to hold primary structures together. They are used in place of mechanical fasteners and thereby reduce leaks, eliminate galvanic corrosion issues, improve vehicle aesthetics, and allow for lighter weight vehicles for better fuel efficiencies.

PRODUCT	CHEMISTRY	AP	EU	NA	MIX RATIO	FIXTURE TIME (MIN.)	CURE TIME (HOURS)	TENSILE STRENGTH MPA	SHEAR STRENGTH STEEL - MPA	ELONGATION %	HARDNESS SHORE D	DESCRIPTION
▶ LOCTITE AA H3000	Acrylic	✓	✓	✓	1:1	15	24	28.2	28.6	25	N/A	Easy to use, one-to-one mix ratio
LOCTITE AA H8000	Acrylic	✓		✓	10:1	30	24	14.8	22.9	13	70	Robust, works on oily metal, excellent weather resistance
LOCTITE EP 5089	Epoxy	✓	✓	✓	1 k, heat cure	N/A	10 min. at 155°C	>30	31.1	9	68	Toughened heat cure epoxy, high shear, peel, impact, and thermal resistance
LOCTITE AA3560	Acrylic	✓			10:1	25 min.	24	19	21	30	69	Halogen-free, for tough, impact-resistant applications

▶ **Product highlighted** = GO TO product

ADHESIVE FEATURES

- High strength bonds
- Can be used to bond dissimilar substrates

ADHESIVES FOR SMALL PART BONDING

When dealing with smaller components, the strength requirements are often very different. With a small bond area, a much higher strength per contact area is required than with larger parts. Smaller parts can also have different requirements under influences such as thermal cycling.

ADHESIVE FEATURES

- Rapid fixture
- Normally primerless

PRODUCT	CHEMISTRY	AP	EU	NA	MIX RATIO	FIXTURE TIME (MIN.)	CURE TIME (HOURS)	TENSILE STRENGTH MPA	SHEAR STRENGTH STEEL - MPA	ELONGATION %	HARDNESS SHORE D	DESCRIPTION
LOCTITE EA 9450	Epoxy			✓	Static Mix (1:1)	13	24	17	23	40	70	Ultra tough, impact resistant
▶ LOCTITE EA E-20HP	Epoxy	✓		✓	Static Mix (2:1)	20	24	39	23	8	80	High strength with exceptional toughness
LOCTITE EA E-60HP	Epoxy	✓		✓	Static Mix (2:1)	60	24	35	30	9	80	High strength with extended cure life and exceptional toughness
▶ LOCTITE HY 4070	Hybrid	✓	✓	X	Static Mix (10:1)	1	24	15	25	5	65	Rapid curing product for metal and plastic part bonding
▶ LOCTITE HY 4080GY	Hybrid	✓	✓	✓	Static Mix (1:1)	10	24	11	26	80	72	Rapid fixturing hybrid adhesive
LOCTITE 480	Cyanoacrylate	✓	✓	✓	1k	2	24	20	26	N/A	N/A	Toughened instant adhesive
LOCTITE HY 4090GY	Hybrid	✓	✓	✓	Static Mix (1:1)	30	168	7.1	17	N/A	67	Rapid fixturing hybrid adhesive with maximum chemical resistance
LOCTITE EA-E-120HP	Epoxy	✓		✓	Static Mix (2:1)	>180	24	40	29	10	N/A	Non-sag epoxy with extended open time to allow alignment

▶ **Product highlighted** = GO TO product

ELASTOMERIC SEALING

ELASTOMERIC SEALANTS

Henkel's elastomeric sealants are formulated to provide a long-term durable seal in both indoor and outdoor environments. Elastomeric sealants can provide the necessary elongation for movement between parts during expansion and contraction, can be used to seal gaps and areas where there may be leaks, and can keep foreign materials at bay. Henkel SMP materials are compatible with most paint systems to allow seamless blending with the exterior finish for enhanced vehicle aesthetics.

ADHESIVE FEATURES

- One component cure for easy application
- UV stability
- High elongation to accommodate thermal expansion of the panels being sealed
- High elongation to allow for increased joint movement

PRODUCT	CHEMISTRY	AP	EU	NA	COLOR	CURE MECHANISM	OPEN TIME (MIN.)	CURE TIME (HOURS)	TENSILE STRENGTH MPA	SHEAR STRENGTH STEEL - MPA	ELONGATION %	HARDNESS SHORE A	DESCRIPTION
TEROSON MS 930	MS Polymer	✓	✓	✓	Black, White, Grey	Moisture	30	24	0.9	N/A	490	25	Low modulus, high elongation sealant for interior and exterior usage
TEROSON 930	MS Polymer	✓	✓	✓	Black, White, Grey	Moisture	30	24	0.9	N/A	490	25	Low modulus, high elongation sealant for interior and exterior usage
▶ TEROSON 935	MS Polymer	✓	✓		White, Black, Grey	Moisture	10	24	2.8	N/A	230	50	Interior and exterior sealing
TEROSON MS 660	MS Polymer		✓		Clear	Moisture	10	24	2.0	N/A	230	40	Interior sealing
▶ TEROSON MS 9320 SF	MS Polymer	✓	✓	✓	Grey	Moisture	10	24	n/a	N/A	N/A	30	Sprayable low viscosity
TEROSON RB 2759	Rubber		✓		Grey	Solvent Evaporation	N/A	N/A	N/A	N/A	N/A	N/A	Sealant for mechanically mounted windows
TEROSON RB 4006	Rubber		✓		Grey	Solvent Evaporation	N/A	N/A	N/A	N/A	N/A	N/A	Sealant for mechanically mounted windows

ELASTOMERIC BONDING PRIMERS/CLEANERS

Most elastomeric bonding systems can benefit from the use of a primer in order to promote adhesion. Some primers also contain a UV blocking agent that when used for glass bonding, protects the bond line from UV light, and eliminates UV degradation of bond strength over time. Henkel provides a range of cleaners that are ideal for ensuring a clean surface for bonding products to deliver maximum performance.

ADHESIVE FEATURES

- Improved adhesion to surfaces
- Rapid preparation time for bonding
- Faster curing
- Increased depth of cure
- Protection from UV

PRODUCT	CHEMISTRY	AP	EU	NA	COLOR	CURE MECHANISM	DRY TIME (MIN.)	ACTIVE TIME	DESCRIPTION
▶ TEROSON PU 8517H	Solvent	✗	✓	✗	Black	Evaporation	5	3 months	Long open time black primer that protects bonds from UV and improves adhesion on glass and ceramic frit.
▶ TEROSON PU 8519P	Solvent	✓	✓	✓	Black	Evaporation	2	60 min.	Black primer that protect bond lines from UV and improve adhesion on materials, especially glass and ceramic frit.
TEROSON PU 8550	Solvent	✗	✓	✗	Clear	Evaporation	0.5	N/A	Cleaner for MS polymers and PU materials
TEROSON PU 8560	Solvent	✗	✓	✓	Clear	Evaporation	0.5	60 min.	Activator/cleaner containing silanes to improve adhesion MS polymers and PU materials
▶ TEROSON SB 450	Solvent	✓	✓	✗	Clear	Evaporation	0.5	60 min.	Active cleaner that improves adhesion of MS polymer, PU, and silicone materials. Has UV marker to inspect application under black light to verify application.
TEROSON VR 20	Solvent	✗	✗	✓	Clear	Evaporation	0.5	N/A	Cleaner designed to be used in window glazing to clean surface and remove silicone residue

▶ **Product highlighted** = GO TO product

LOCTITE
TEROSON

NOISE
VIBRATION
HARSHNESS
METAL REINFORCEMENT

The graphic features a central circular design with a gear-like outer edge. The text 'LOCTITE' is in red and 'TEROSON' is in black, both in a bold, italicized font. Surrounding the center are four terms: 'NOISE', 'VIBRATION', 'HARSHNESS', and 'METAL REINFORCEMENT', each with a red arrow pointing towards the center. Below the main graphic are two inset images: on the left, a high-speed train in motion; on the right, a cross-section of a train seat showing its internal structure and blue upholstery.

NVH AND PROTECTIVE COATINGS

CREATE STRONGER AND QUIETER EQUIPMENT

Henkel's solutions to reduce noise, vibration, and harshness (NVH) were originally designed for automotive vehicle cabins and are now used in rail equipment manufacturing. Our *TEROSON*® brand NVH solutions and *LOCTITE*® brand adhesives and sealants help enhance material properties and minimize noise.

NVH SOLUTIONS

Henkel is a leading source worldwide for NVH (noise, vibration, and harshness) solutions. We provide advanced NVH technologies and comprehensive design and engineering support to our customers. Henkel has been an NVH partner with the top automotive manufacturers for more than 20 years, and our expertise helps rail equipment manufacturers create dimensionally stronger and quieter products. Our *TEROSON*® brand NVH solutions and *LOCTITE*® brand adhesives and sealants help enhance material properties and minimize audible noises.

NVH PRODUCT PORTFOLIO AND TECHNOLOGIES

- Henkel offers a full portfolio of NVH solutions in five categories – **reinforcement, damping, sealing, absorption, and barrier** – detailed in Figure 1.
- Our portfolio covers **15 core technologies** through the frequency range of 0.1 Hz up to 20 kHz. In addition, our capabilities allow us to provide solutions outside our core technologies.
- We provide effective solutions to **airborne noise and structure-borne noise**, as well as **vibration and leakage**.
- We help our customers achieve **high performance sealing and save on process cost** through automation.

APPLICATION	REINFORCEMENT 
NEED	Increase stiffness, shift resonant frequency
SOLUTION	Reinforce with stiffening pads
	<ul style="list-style-type: none"> • Structural vibration reduction • Allows metal design with thinner panels • Reduction in mass

VIBRATION RESPONSE TEST (FIGURE 2)

> BEFORE

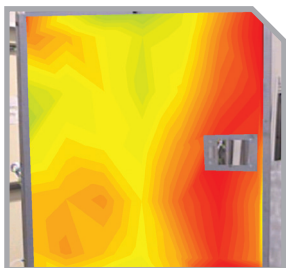

Vibration response test for side panel. Red/yellow indicates high levels of vibration.

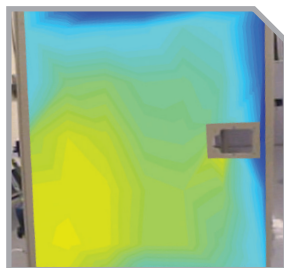

> AFTER

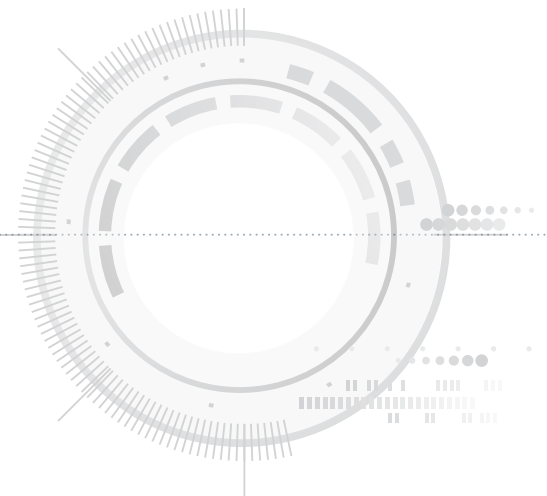

Test results for side panel using Henkel expandable material. Blue/green indicates low levels of vibration.

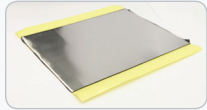

NOISE, VIBRATION, AND HARSHNESS SOLUTIONS (FIGURE 1)

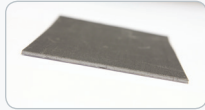
<p>DAMPING</p> 	<p>SEALING</p> 	<p>ABSORPTION</p> 	<p>BARRIER</p> 
<p>Attenuate vibration of panel structure</p>	<p>Isolate noise sources</p>	<p>Reduce reverberant noise</p>	<p>Block sound transmission</p>
<ul style="list-style-type: none"> • Liquid applied sound deadener • Water-based damping • High damping foam • Constrained layer pads 	<p>Semi-Structural Adhesive/Sealant</p>	<p>Acoustic Barrier/Absorber</p>	
<ul style="list-style-type: none"> • High loss factor performance • Structural vibration reduction • Improves NVH performance • Converts vibration into thermal energy • Reduction in sound pressure levels • Easy to apply on various substrates 	<ul style="list-style-type: none"> • Less welding • Less corrosion • Process cost savings through automation 	<ul style="list-style-type: none"> • High Sound Transmission Loss (STL) performance • High absorption performance • Tunable performance • Complexity reduction 	

NVH TECHNOLOGY OVERVIEW

<p>FREQUENCY</p>	<p>16 kHz</p>	<p>AIRBORNE NOISE</p>	<p>BARRIER</p>	<ul style="list-style-type: none"> > Multilayer with EVA Sound Insulation > Fiber (Nonwoven) Absorber > Open Cell Foam Absorber > Preformed Mastic Parts (Non-Expanding) > Preformed Parts: Expandable Soft Foams
	<p>1 kHz</p>		<p>ABSORPTION</p>	
<p>100 Hz</p>	<p>STRUCTURAL NOISE</p>	<p>DAMPING</p>	<p>REINFORCEMENT</p>	<ul style="list-style-type: none"> > Bitumen Sheets > Constrained Layer Damping Pads (CLD) > Aqueous Synthetic Damping - Large Surface (rail) > Liquid Applied Sound Deadener (LASD) > Pumpable Anti-Flutter > Bonding With Semi-Structural Adhesives > Bonding With Structural Adhesives > Injection of Structural Hard Foams - RT - RIM > Preformed Parts: 3D Structural Foam - Thin Gauge Metal (auto) > Preformed Parts: 2D Structural Tapes and Pads
<p>20 Hz</p>				

ACOUSTIC COATINGS/PADS FOR NOISE CONTROL

INTERIOR NVH COATINGS

Henkel is a leading provider of materials designed to be applied to the interior shell of rail coaches to reduce noise, vibration and harshness to ensure passenger comfort. These products are ideal for interior applications where there is a need to reduce sound from flat surfaces producing noise within a sealed structure.

ADHESIVE FEATURES

- Easy to apply
- Solvent-free
- Spray applied formula available
- Low VOC

PRODUCT NAME	AP	EU	NA	SERVICE TEMPERATURE °C	COLOR	DRYING TIME (4 MM WET FILM) (DIN EN ISO 291) HOURS	LOSS FACTOR FOR 2 MM DRY FILM (DIN EN ISO 6721-3 (200C, 200 HZ, SHEET STEEL 1 MM))	DENSITY, WET/ DRY G/CM3	SOLIDS CONTENT %
<i>TEROSON</i> WT 112 DB	✓	✓		-50°C to 120°C	Beige	24	>=0.22	1.40 / 1.20	67
<i>TEROSON</i> WT 123 FF	✓			-50°C to 120°C	Beige	24		1.3-1.6 (wet)	66-72
<i>TEROSON</i> WT 123 FRF	✓			-50°C to 120°C	Beige	24	>=0.22	1.40 / 1.20	66-72
<i>TEROSON</i> WT 123 GRT	✓			-50°C to 120°C	Beige	24	>=0.10	1.40	68-75
<i>TEROSON</i> WT 123 WF	✓			-50°C to 120°C	Beige	24	>=0.19	1.40 / 1.3	73
▶ <i>TEROSON</i> WT 129	✓	✓	✓	-50°C to 120°C	Beige	24	>=0.19	1.34 / 1.2	70

▶ Product highlighted = GO TO product

UNDERBODY PROTECTIVE COATINGS

TEROSON® protective coatings are designed to be applied to the bottom of rail carriages. They protect the bottom of the vehicle from stone and other damage by forming a continuous coating that is impact-and-water-resistant. The coatings ultimately maintain the structural integrity of the floor system and reduce noise to produce a quieter environment for passengers.

ADHESIVE FEATURES

- Easy to apply
- Noise reduction
- Anti-stone/chip

PRODUCT NAME	AP	EU	NA	COLOR	DRYING TIME (4 MM WET FILM) (DIN EN ISO 291) HOURS	LOSS FACTOR FOR 2 MM DRY FILM EN ISO 6721-3 (200C, 200 HZ, SHEET STEEL 1 MM)	DENSITY, WET/ DRY G/CM3	SOLIDS CONTENT %	NOTES
<i>TEROSON</i> WT 218	✓	✓		Grey	22 - 48 depending on thickness applied	>= 0.05	1.23	67	High Abrasion Resistance
▶ <i>TEROSON</i> WT 218 FR 200	✓	✓	✓	Grey	21 - 48 depending on thickness applied	>= 0.05	1.53	77	Good Fire Behavior

▶ Product highlighted = GO TO product

ANTI-SLIP FLOOR COATINGS AND UNDERBODY PROTECTIVE COATINGS

ANTI-SLIP FLOOR COATINGS

Rail service workers often need to work on the roof or access areas using narrow passages. Coating these low-traffic, but potentially higher risk areas with our anti-slip floor coatings reduces job-related slips and falls and increases workplace safety. These coatings are also recommended for ramps, stairs, walkways, and other pedestrian service areas.

ADHESIVE FEATURES

- Roller, spray, and trowel applications available
- Can be used on multiple surfaces
- Good flexibility
- Work in wet environment
- Good chemical, moisture, and UV resistance
- Indoor and outdoor suitable

PRODUCT NAME	AP	EU	NA	CHEMICAL BASE	COLOR	UV RESISTANT	WET EXPOSURE	RECOMMENDED PRIMER METAL SURFACES	RECOMMENDED PRIMER WOOD, TILE, AND POROUS SURFACES	USE FOR	ALSO KNOWN AS
<i>LOCTITE</i> PC 2760 RAIL	✓			Epoxy	Black	Some	Intermittent	<i>LOCTITE</i> PC 7643 Metal Primer	<i>LOCTITE</i> PC 6241 Water-Based Primer	Wood, concrete, and metal surfaces to increase traction to minimize falls. Not for continuously wet environments.	Heavy Duty Pedestrian Grade
<i>LOCTITE</i> PC 6255			✓	Acrylic	Grey or Black	Yes	Yes	<i>LOCTITE</i> PC 7643 Metal Primer	<i>LOCTITE</i> PC 6253 Acrylic Primer	Best for metal surfaces subject to thermal cycling due to good flexibility.	Acrylic Pedestrian Grade
<i>LOCTITE</i> PC 6261			✓	Epoxy	Grey or Black	Some	Intermittent	<i>LOCTITE</i> PC 7643 Metal Primer	<i>LOCTITE</i> PC 6241 Water-Based Primer	Wood, concrete, and metal surfaces to increase traction to minimize falls. Not for continuously wet environments.	Heavy Duty Pedestrian Grade

For metal surfaces we recommend a primer to ensure optimal adhesion and service life.

Anti-slip floor coatings can be applied by the OEM manufacturer or the end transit or rail operator.



MACHINERY ADHESIVES AND MAINTENANCE

THREADLOCKING, THREADSEALING, RETAINING, GASKETING, LUBRICATING, AND REPAIRING WITH **LOCTITE® PRODUCTS**

Henkel's wide range of *LOCTITE*® threadlocking, thread sealing, gasketing, and retaining products help manufacturers increase reliability and reduce downtime. Our innovative and reliably engineered adhesives replace mechanical locking and sealing methods, prevent loosening from vibration, strengthen the assembly, and protect against leaks and corrosion.

THREAD SEALING

THREAD SEALANTS

LOCTITE® anaerobic thread sealants prevent leakage of gases and liquids. Designed for low pressure and high pressure applications, they fill the space between threaded parts and provide an instant, low pressure seal. When fully cured, they seal to the burst strength of most pipe systems. Thread Sealants prevent loosening from shock and vibration, as well as fill air voids to prevent leakage of fluid/gas being sealed.

ADVANTAGES VERSUS TRADITIONAL SEALANT TYPES

- Single component – clean and easy to apply or automate
- Allows for precision alignment, versus PTFE tapes which do not allow adjustment
- Can be used on any size of pipe fitting
- Resists vibration and shock loads
- Protect mated threaded areas against corrosion and galling

	PRODUCT	AP	EU	NA	TYPICAL USE	COLOR AND APPEARANCE	VISCOSITY (CP)	TEMPERATURE RANGE	PRESSURE RESISTANCE (PSI)	RECOMMENDED PRIMER	AGENCY APPROVALS
Hydraulic and Pneumatic	LOCTITE® 542 PIPE SEALANT	✓	✓	✓	Hydraulic lines, smaller pneumatic fittings	Brown	2,000	-65°F to 300°F (-54°C to 149°C)	10,000	SF 7088, SF 7649, or SF 7471	DVGW WRAS
	LOCTITE® 5452 THREAD SEALANT	✓		✓	Pneumatic hydraulic sealant, no fillers	Purple	29,000/200,000 thixotropic	-65°F to 300°F (-54°C to 149°C)	10,000	SF 7088, SF 7649 or SF 7471	
	LOCTITE® 545 PIPE SEALANT	✓	✓	✓	Hydraulic lines, smaller pneumatic fittings	Purple	14,000	-65°F to 300°F (-54°C to 149°C)	10,000	SF 7088, SF 7649, or SF 7471	ABS, CFIA
General-Purpose	LOCTITE® 561 PIPE SEALANT	✓	✓	✓	General-purpose, portable, overhead	White Paste	Semisolid	-65°F to 300°F (-54°C to 149°C)	10,000	SF 7088, SF 7649 or SF 7471	UL Classified for U.S., CFIA Listed, NSF / ANSI 61
High Temperature	▶ LOCTITE® 567 THREAD SEALANT	✓	✓	✓	For stainless steel and all other metal fittings; designed for Taper/Taper NPT Fittings	White	540,000	-65°F to 400°F (-54°C to 204°C)	10,000	SF 7088, SF 7649 or SF 7471	UL Classified for U.S., ABS, CFIA Listed, NSF / ANSI 61, ULC Classified for Canada
	▶ LOCTITE® 577 THREAD SEALANT	✓	✓	✓	For European taper to straight piping standard	Yellow	24,000/80,000 Thixotropic	-65°F to 260°F (-54°C to 180°C)	10,000	SF 7088, SF 7649 or SF 7471	DGWW, NSF P1

LOCTITE® PRIMERS

PRODUCT	AP	EU	NA	COLOR	VISCOSITY (CP)	BASE	ON-PART LIFE	DRY TIME	APPLICATION	AGENCY APPROVALS
LOCTITE® SF 7088 PRIMER	✓		✓	Teal	Semisolid	No solvent	30 days	None	Anaerobics	N/A
LOCTITE® SF 7471 PRIMER	✓	✓	✓	Amber	2	Acetone / Isopropanol	7 days	30 to 70 seconds	Anaerobics	MIL-S-22473E for existing designs, ASTM D-5363 for new designs
▶ LOCTITE® SF 7649 PRIMER	✓	✓	✓	Clear / Green	2	Acetone	30 days	30 to 70 seconds	Anaerobics	MIL-S-22473E for existing designs, ASTM D-5363 for new designs, NSF / ANSI 61, NSF P1, CFIA Listed

▶ Product highlighted = GO TO product

THREADLOCKING

THREADLOCKERS

LOCTITE® threadlockers dramatically increase the reliability of threaded assemblies. Available as liquid and semisolid adhesives, LOCTITE threadlockers are applied to the threads of a fastener and cure to a hard thermoset plastic when situated between metal surfaces. They cure in the absence of air and completely fill the gaps between mating threads to lock and seal threads and joints. Threadlockers bond metal fasteners to prevent loosening from shock and vibration, as well as fill voids to seal and protect threads from rust and corrosion.

ADVANTAGES VERSUS TRADITIONAL MECHANICAL LOCKING DEVICES

- Fill air void to seal and protect threads from rust and corrosion
- Single component – clean and easy to apply or automate
- Can be used on various sizes of fasteners – reduced inventory costs
- Prevents unwanted movement, loosening, leaks, and corrosion
- Resist vibration

	KEY FEATURES	PRODUCT	AP	EU	NA	TYPICAL USE	PACKAGE TYPE AND SIZE	COLOR	VISCOSITY** (CP)	TORQUE*** IN.-LBS. (Break/Prevail)	TEMPERATURE RANGE	CURE SPEED (STEEL AT 25°C)	AGENCY APPROVALS
Low Strength	Small Fasteners	LOCTITE 222 THREADLOCKER	✓	✓	✓	Small screws under 1/4 in.	10 ml bottle 50 ml bottle	Purple	1,200 / 5,000 Thixotropic	53 / 30	-65°F to 300°F	Fixture – 20 min. Full – 24 hrs.	N/A
	► General-Purpose	LOCTITE 243 BLUE THREADLOCKER	✓	✓	✓	1/4 in. to 3/4 in. bolts with light oil contamination	50 ml bottle 250 ml bottle 1 liter bottle	Blue	1,300 / 3,000 Thixotropic	230 / 40	-65°F to 360°F	Fixture – 10 min. Full – 24 hrs.	NSF/ANSI 61, CFIA Listed
Medium Strength	Semisolid Stick	LOCTITE 248 BLUE THREADLOCKER	✓	✓	✓	1/4 in. to 3/4 in. bolts, overhead, pre-dispensed, hard-to-reach areas	9 g stick 19 g stick	Blue	Semisolid	110* / 43	-65°F to 300°F	Fixture – 5 min. Full – 24 hrs.	CFIA Listed
	Tape	LOCTITE 249 BLUE THREADLOCKER TAPE			✓	1/4 in. to 3/4 in. bolts, overhead, pre-dispensed, hard-to-reach areas	260 in. roll	Blue	Tape	74 / 47	-65°F to 300°F	Fixture – 30 min. Full – 24 hrs.	CFIA Listed
High Strength	► General-Purpose	LOCTITE 263 HIGH STRENGTH THREADLOCKER	✓		✓	Primerless, high strength	50 ml bottle 250 ml bottle 1 liter bottle	Red	400 / 600	290 / 290*	-65°F to 360°F	Fixture – 10 min. Full – 24 hrs.	NSF/ANSI 61, CFIA Listed
	Semisolid Stick	LOCTITE 268 THREADLOCKER – HIGH STRENGTH	✓	✓		Up to 3/4 in. bolts, overhead, pre-dispensed, hard-to-reach areas	9 g stick 19 g stick	Red	Semisolid	220* / 34	-65°F to 300°F	Fixture – 5 min. Full – 24 hrs.	CFIA Listed
Wicking Grade	► General-Purpose	LOCTITE 270 THREADLOCKER	✓		✓	Primerless, high strength	50 ml bottle 250 ml bottle 1 liter bottle	Red	400 / 600	290 / 290*	-65°F to 360°F	Fixture – 10 min. Full – 24 hrs.	NSF/ANSI 61
	General-Purpose	LOCTITE 290 THREADLOCKER	✓	✓	✓	Medium/high strength, wicking grade for preassembled parts and weld sealing	50 ml bottle 250 ml bottle 1 liter bottle	Green	25 / 55	90 / 260	-65°F to 300°F	Fixture – 20 min. Full – 24 hrs.	MIL-S-46163A for existing designs, ASTM D-5363†, NSF/ANSI 61, NSF P1, CFIA Listed

► Product highlighted = GO TO product

* Break loose value.

† For new designs.

RETAINING

RETAINING COMPOUNDS

LOCTITE® anaerobic retaining compounds secure bearings, bushings, and cylindrical parts into housings or onto shafts. They achieve maximum load transmission capability and uniform stress distribution, and eliminate fretting corrosion. Applied as a liquid, they form a 100% contact between mating metal surfaces, eliminating the need for expensive replacement parts, time-consuming machining or the use of mechanical methods.

ADVANTAGES VERSUS CONVENTIONAL ASSEMBLY METHODS

- High shear strength – augments or replaces press fits
- 100% contact – evens distribution of load and stress
- Eliminates fretting and backlash in keys and splines
- Fills air voids to seal and protect from corrosion and fretting
- Relaxes part tolerances

LOCTITE RETAINING COMPOUNDS

PRODUCT	AP	EU	NA	TYPICAL USE	COLOR	MAXIMUM GAP FILL (DIAMETER-INCHES)	VISCOSITY (CP)	SHEAR STRENGTH STEEL / STEEL* (PSI)	TEMPERATURE RANGE	CURE SPEED*	RECOMMENDED PRIMER
LOCTITE® 540 RETAINING COMPOUND	✓		✓	Cup / core plug adhesive sealant	Blue	N/A	7,000 to 12,000	2,030	-65°F to 300°F (-54°C to 149°C)	N/A	SF 7649 or SF 7471
▶ LOCTITE® 603 RETAINING COMPOUND	✓	✓	✓	For close-fitting parts with light contamination	Green	0.005 in.	125	3,770	-65°F to 300°F (-54°C to 149°C)	Fixture - 10 min. Full - 24 hrs.	SF 7088, SF 7649 or SF 7471
LOCTITE® 620 RETAINING COMPOUND	✓	✓	✓	For high temperature applications	Green	0.015 in.	8,500	3,800	-65°F to 450°F (-54°C to 232°C)	Fixture - 1 hr. Full - 24 hrs.	SF 7088, SF 7649 or SF 7471
LOCTITE® 638	✓	✓	✓	High strength, primerless, oil tolerant, for slip-fitted products	Green	0.010 in. (0.25 mm)	2,500, 4,500		-65°F to 355°F (-54°C to 180°C)	Fixture- 4 min Full - 24 hrs	Not Required
▶ LOCTITE® 648 RETAINING COMPOUND	✓	✓	✓	Fast fixturing for close-fitting parts, high strength for stainless steel	Green	0.006 in.	500	3,900	-65°F to 355°F (-54°C to 180°C)	Fixture - 5 min. Full - 24 hrs.	SF 7088, SF 7649 or SF 7471
LOCTITE® 660 RETAINING COMPOUND	✓	✓	✓	For repair of worn machinery parts	Silver	0.020 in.	250,000 / 1,500,000 Thixotropic	3,335	-65°F to 300°F (-54°C to 149°C)	Fixture - 20 min. Full - 24 hrs.	SF 7088, SF 7649 or SF 7471
LOCTITE® 668 RETAINING COMPOUND	✓		✓	Bonding of cylindrical fitting parts	Green	0.005 in.	Semisolid	2,610	-65°F to 400°F (-54°C to 204°C)	Fixture - 30 min. Full - 72 hrs.	SF 7649 or SF 7471

▶ Product highlighted = GO TO product

* Varies with substrates.



GASKETING

GASKETING PRODUCTS

LOCTITE® gasketing products are self-forming gaskets that provide a perfect seal between components, with maximum face-to-face contact, eliminating flange face corrosion. They form a low-pressure seal immediately on assembly and fully cure in 24 hours, providing a joint that will not shrink, crack, or relax. They are available as anaerobic products for rigid flanges and silicone products for flexible flanges.

ADVANTAGES VERSUS CONVENTIONAL PRECUT COMPRESSION GASKETS

- Fill all voids – relaxes the tolerances and preparation of flange surfaces
- Can be used on various flange configurations – reduce inventory costs
- Eliminate shimming and compression setting – no need for re-torquing
- Seal liquids and gases, and protect flanges from corrosion
- Unitize flange assemblies for added reliability and high resistance to solvents

LOCTITE ANAEROBIC GASKETING PRODUCTS

PRODUCTS	AP	EU	NA	COLOR	TYPICAL USE	GAP FILL (INCHES)	CURED STATE	VISCOSITY (CP)*	TEMPERATURE RANGE	CURE SPEED	RECOMMENDED PRIMER	SPECIFIC GRAVITY	AGENCY APPROVALS
LOCTITE 510 FLANGE SEALANT	✓	✓	✓	Red	High temp. applications, excellent solvent resistance	Unprimed – 0.010 Primed – 0.020	Rigid	90,000 / 500,000 Thixotropic	-65°F to 400°F (-54°C to 204°C)	Unprimed – 4 to 24 hrs. Primed – 30 min. to 4 hrs.	SF 7088, SF 7471 or SF 7649	1.16	N/A
▶ LOCTITE 518 FLANGE SEALANT	✓	✓	✓	Red	For all metals, including aluminum flanges	Unprimed – 0.010 Primed – 0.050	Flexible	800,000 / 3,750,000 Thixotropic	-65°F to 300°F (-54°C to 149°C)	Unprimed – 4 to 24 hrs. Primed – 30 min. to 4 hrs.	SF 7088, SF 7471 or SF 7649	1.13	NSF / ANSI 61, CFIA Listed
LOCTITE 5128 FLANGE SEALANT			✓	Red	For all metals, including aluminum flanges	Unprimed – 0.010 Primed – 0.020	Highly Flexible	10,000 / 50,000 Thixotropic	-65°F to 300°F (-54°C to 149°C)	Unprimed – 4 to 24 hrs. Primed – 30 min. to 4 hrs.	SF 7088, SF 7471 or SF 7649	1.10	N/A

* NOTE: Different test methods were used. Please see SDS, or consult with Henkel Engineering for test specifications.

LOCTITE SILICONE GASKETING PRODUCTS

PRODUCTS	AP	EU	NA	COLOR	CONSISTENCY	OIL RESISTANCE	TEMPERATURE RANGE (INTERMITTENT)	SEALING TIME	AGENCY APPROVALS
LOCTITE SI 587 BLUE, HIGH PERFORMANCE RTV SILICONE GASKET MAKER	✓		✓	Blue	Paste	Increased oil resistance	-75°F to 500°F (-59°C to 260°C)	Tack-free – 30 min. Full strength – 24 hrs.	NSF P1, CFIA Listed, ABS
▶ LOCTITE SI 5900	✓	✓	✓	Black	Paste	Oil / water resistant	-65°F to 500°F (-54°C to 260°C)	Tack-free – 30 min. Full strength – 24 hrs.	NSF P1, CFIA Listed
LOCTITE SI 5699 GREY, HIGH PERFORMANCE RTV SILICONE GASKET MAKER	✓	✓	✓	Grey	Paste	Increased oil resistance	-75°F to 625°F (-59°C to 329°C)	Tack-free – 30 min. Full strength – 24 hrs.	CFIA Listed

▶ **Product highlighted** = GO TO product

ANTI-SEIZE LUBRICANTS

ANTI-SEIZE LUBRICANTS

LOCTITE® anti-seize products provide lubrication as well as protection against rust, corrosion, seizing and galling. Anti-seizes are typically the products of choice for high temperature applications because of their unique ability to provide protection in extreme temperature conditions. Each product contains a combination of solid lubricating agents resulting in different high temperature limits and lubricities

KEY ADVANTAGES OVER GREASE ALTERNATIVE

- Allows for disassembly following high temperature service
- Protects from galling and seizure under high stress environment

	ALSO KNOWN AS	AP	EU	NA	COLOUR	SOLID LUBRICATING AGENT	TORQUE COEFFICIENT	TEMPERATURE RANGE CELSIUS	"METAL FREE (Y/N)"	DESCRIPTION
LOCTITE LB 771	Nickel Anti-Seize			✓	Silver	Nickel/ Graphite	0.13	-30°C to 1315°C	N	Best for very high temperature applications
LOCTITE LB 8007	C5-A Copper-Based Anti-Seize		✓		Copper	Copper/ Graphite	0.16	-30°C to 980°C	N	Copper based formula Aerosol Version spray can
LOCTITE LB 8008	C5-A Copper-Based Anti-Seize		✓	✓	Copper	Copper/ Graphite	0.16	-30°C to 980°C	N	Copper based formula
LOCTITE LB 8009	Heavy Duty Anti-Seize		✓	✓	Grey	Calcium Carbonate / Graphite	0.16	-30°C to 1315°C	Y	Metal Free, all metals but especially Stainless Steel and Aluminum
▶ LOCTITE LB 8023	Marine Grade Anti-Seize		✓	✓	Black	Calcium Sulfonate	0.18	-30°C to 1315°C	Y	Works well for high humidity, fresh and salt water exposure. Very high wash out resistance
LOCTITE LB 8044	Zinc Anti-Seize			✓	Grey	Zinc	0.15	-30°C to 400°C	N	Best for salt metals. Protects aluminum and ferrous surfaces from seizure
LOCTITE LB 8065	C5-A Copper-Based Anti-Seize			✓	Copper	Copper/ Graphite	0.16	-30°C to 980°C	N	Copper based formula semi-solid stick
LOCTITE LB 8070	Heavy Duty Anti-Seize			✓	Grey	Calcium Carbonate / Graphite	0.16	-30°C to 1315°C	Y	Metal Free, all metals but especially Stainless Steel and Aluminum semi-solid stick
▶ LOCTITE LB 8150	Silver Grade Anti-Seize		✓	✓	Silver	Graphite/ Aluminum	0.18	-30°C to 870°C	N	Standard Anti-Seize for most applications. Very robust
▶ LOCTITE LB 8151	Silver Grade Anti-Seize		✓		Silver	Graphite/ Aluminum	0.18	-30°C to 870°C	N	Standard Anti-Seize for most applications. Very robust Aerosol version of LB 8150
LOCTITE LB 8507	Nickel Anti-Seize		✓		Silver	Nickel/ Graphite	0.13	-30 °C to 1315°C	N	Best for very high temperature applications Aerosol version of Product 771

▶ Product highlighted = GO TO product



GAP FILLING SOLUTIONS

GAP FILLING SOLUTIONS

BODY FILLERS

During production there is always a requirement to produce a smooth seamless design. Due to material constraints and tolerances, products are required to build up surfaces in order to get a flush finish. This is especially noticeable where FRP parts are bonded to metal parts like end caps. FRP is dimensionally less stable than metal so body fillers are employed in the finishing operation prior to painting.

Henkel offer a wide range of such products, but due to regional chemical regulations each area has a unique offering. Please contact your Henkel representative for the local offering.

POTTING

Many devices require sealing for environmental protection or tamper resistance. In the case of electrical parts, one of the most common requirements is making sure that they are sealed from exposure to water. A common solution is to use a low viscosity material called a potting compound. The low viscosity characteristic of the resin allows it to flow around and encapsulate electronic components within a structure in order to protect them from moisture.

Product selection is based on many requirements such as chemical resistance, process time, accuracy, health and safety, cure time, fixture time, cost, color, etc. Henkel is unique in the market in that we offer options in virtually every major adhesive chemistry which allows us to recommend the best solution for the customer based on specific needs.

OTHER GAP FILLING SOLUTIONS

Henkel is willing to go beyond standard application issues and work with you to solve design challenges that you have never seen before. With our extensive portfolio and experience, it is a core part of our culture to develop innovative solutions.

For more information, please contact your local representative.

REGULATORY OVERVIEW AND TOTAL SOLUTIONS FROM HENKEL

Regulatory testing requirements and approvals are in place in order to ensure passenger safety in case of an emergency. Collectively, the testing is known as FST: Fire, Smoke, and Toxicity testing, working towards keeping passengers safe in case on an emergency.

EN 45545

This Fire, Smoke, and Toxicity approval applies to the European Union (EU) countries and is one of the most widely used employed standards. It details level of protection, HL1 to HL3. It also covers specific application ranges, referred to as R1 to R26. Qualification is completed to specific application ranges, as no blanket qualification exists. Henkel products meet a number of application ranges within this standard.

NFPA 130

This approval is part of the National Fire Protection Association (NFPA) standard 130 which covers passenger rail. It is mandatory in the USA, but adopted in most countries of the Americas, as well as many other parts of the world. Henkel has a range of products that meet this standard as it has a single test for all adhesives.

BSS 7239

This Boeing standard is employed for toxicity of gas produced in a fire. No pass/fail criteria exists; testing only requires that a quantitative reading be measured. Henkel can provide the results for a range of products.

SMP-800C

This aerospace toxicity of gas produced in a fire test is similar to BSS 7239, but contains a pass/fail criterion. Henkel has data on a range of products.

ASTM E-1354

This test is widely used to calculate the heat generated during a fire within a rail vehicle by its manufacturer. Its goal is to determine if a vehicle fire would produce enough energy to damage infrastructure such as a tunnel or bridge, which could cripple a rail line.

TB/T3139

This test applies to China only and is a analysis of chemical content. Henkel has data on a range of products.

Other Regulatory Requirements

Beyond these tests additional country specific test exist for many other countries such as India, Japan, Russia and others.

RAIL – as part of public infrastructure requires many local and regional approvals. Contact your local Henkel to learn more about regulations in your area.

In addition to offering the **broadest product portfolio** in the adhesives industry, Henkel provides an array of services to help our rail equipment customers **optimize** their manufacturing process, **improve** efficiency and **reduce** overall costs.

THE FOLLOWING SERVICES ARE AVAILABLE WORLDWIDE:



MANUFACTURING EXCELLENCE

Henkel has decades of success optimizing manufacturing processes. We can analyze your complete manufacturing process and provide tailor-made recommendations on how to reduce production cycle times and rejection rates, thereby lowering your overall costs and increasing your productivity.



LAB TESTING

Henkel's testing capabilities can provide complete data on our product recommendations. Whether you want to analyze a single component of your production process or review the complete system, our labs can provide all the data you need.



CUSTOMER TRAINING

Henkel offers a wide selection of customized training programs to help customers learn the details of our product technologies and how to apply them effectively. We can also train you to use our custom-designed equipment efficiently. Our Technology Days provide additional training and demonstrations of our newest innovations.

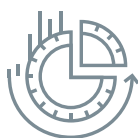

VALUE CALCULATORS

Using our Value Calculators, our adhesives specialists can accurately analyze the total cost of your adhesive processes and determine your savings potential. Simply arrange an appointment with our specialists, and they will visit your production facilities to conduct an in-depth analysis.



ANALYTICAL SERVICES

Henkel provides comprehensive analyses of all steps in your manufacturing process using our own industry experts. We will identify problem points on the production line and recommend improvements to the manufacturing process. These services can also include equipment teardowns, surface analysis, and testing.

LOCTITE®
BONDERITE®
TECHNOMELT®
TEROSON®
AQUENCE®

AMERICAS

U.S.A

Henkel Corporation
32100 Stephenson Highway
Madison Heights, Michigan 48071
United States
Tel: +1.866.332.7024
Fax: +1.248.583.2976

EUROPE

GERMANY

Henkel AG & Co. KGaA
Henkelstraße 67
40191 Düsseldorf
Germany
Tel.: +49.211.797.0
Fax: +49.211.798.4008

ASIA

CHINA

Henkel (China) Co. Ltd.
188 Guoyuan Road, Yancang
Nanhu District
201324 Shanghai
China
Tel: +86.21.6826.7097
Fax: +86.21.6826.7654v

henkeladhesives.com/us/en/industries/automotive-and-transportation/rail