

LOCTITE®

**ADHESIVE & SEALANT
SOLUTIONS THAT
STOP LEAKS BEFORE
THEY START**



Henkel

LOCTITE ADHESIVES AND SEALANTS

Solving leak problems. Ensuring peace of mind.

Leaks are a significant and common problem for manufacturing, assembly, installation, and maintenance professionals. While a certain amount of leakage used to be accepted in the past, leaks are no longer tolerated in today's marketplace. With our technical knowledge, industry experience and innovative sealant and adhesive technologies, we examine the source and help you design new solutions that impact your business.



PROTECTS YOUR BRAND REPUTATION

Better leak prevention and product reliability. Fewer warranty claims.



LOWERS YOUR COSTS

Eliminating costs associated with traditional fastening and sealing technologies.



IMPROVES YOUR COMPETITIVENESS

Separating your product performance from others. New found design freedom fosters innovation.

Solutions for today's challenges.



INCREASED RELIABILITY

Thread sealing applications call for higher temperatures, higher pressures and resistance to harsher chemicals. Demands for increased reliability have pushed the boundaries of conventional sealant technology which LOCTITE sealants have overcome.

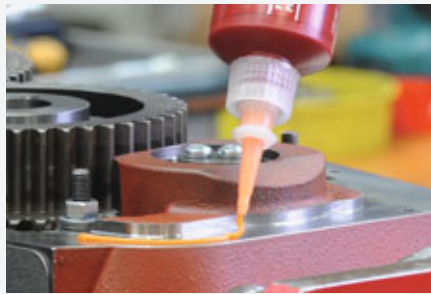

LEAK PREVENTION

Pre-cut gaskets have a limited ability to fill in surface irregularities and create a seal. LOCTITE liquid gasket material can flow into surface irregularities and create a leak-free seal.

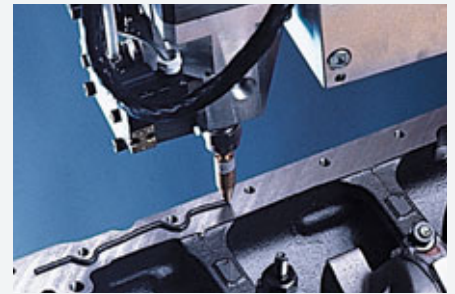

PROCESS OPTIMISATION

Henkel offers various dispensing and curing equipment that can be easily integrated into your manufacturing process to increase efficiency and throughput. Equipment includes manual or pneumatic, portable or stationary, and pressure-time or volumetric dispense systems.

A trusted partner in leak prevention.

LOCTITE adhesives and sealants are engineered to meet a broad range of fluid processing applications. With our world-class, innovative product technologies and our extensive industry experience, Henkel can help you optimise product performance and reduce overall costs.



SOLUTIONS FOR A WIDE RANGE OF NEEDS

Our range of solutions.

Thread Sealing

SEALING THREADED COMPONENTS

- Seals against aggressive fluids / high pressure
- Prevents corrosion
- Suitable for all thread types
- Replaces seals & O-rings
- Adjustable joints / no re-torquing necessary

BENEFITS

- Improved reliability / extended life expectancy
- Lower service and repair costs
- Fewer parts / lower inventory costs

Gasketing

SEALING FLANGES

- 100% metal to metal contact – no leakage
- Fills surface defects
- Helps reach high IP rating
- No gasket relaxation nor displacement
- Can replace compression gaskets and o-rings

BENEFITS

- Lower inventory costs and complexity reduction – eliminate need to store different gasket types
- Increased reliability / product life

Threadlocking

LOCKING THREADED FASTENERS

- Locking against vibration – no bolt loosening
- Fill all voids – prevent relative movement
- Prevents corrosion
- Replaces traditional mechanical locking devices

BENEFITS

- Improvement / preservation of clamp load
- Improved reliability / extended life expectancy
- Lower service and repair costs

Retaining

SECURING CYLINDRICAL ASSEMBLIES

- Allows higher load transfer with existing designs
- Prevents fretting corrosion and micromovements
- Replaces mechanical fasteners
- Allows slip fits / replaces or enhances interference fits

BENEFITS

- Reduced costs
- Increased reliability for longer product life
- Cost-efficient designs (fewer components / reduced tolerance)
- Higher mechanical strength

Structural & Instant Bonding

JOINING AND SEALING DISSIMILAR MATERIALS

- Fill gaps, allow wider tolerances
- Prevent stress concentration from traditional joining methods

BENEFITS

- Flexibility in substrate design
- Fewer parts / simpler design
- Lower cost / lower weight
- Super fast-curing grades available

Complementary Solutions

To complete the product portfolio across the entire value chain, Henkel offers various other solutions to cover your needs:

- **LOCTITE anti-seize** products to protect parts against rust, corrosion, seizing and galling, and for lubricating parts
- **LOCTITE potting and encapsulating compounds** to fill large voids, and protect components from exposure to chemicals, moisture, shock and vibration
- **LOCTITE cleaners** for parts cleaning prior to bonding
- **BONDERITE cleaners** to clean and protect parts during all phases of your manufacturing process

For a range of fluid processing devices.

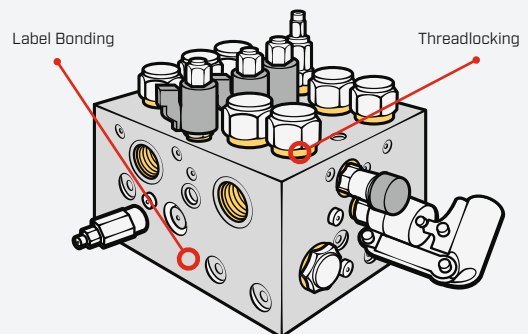
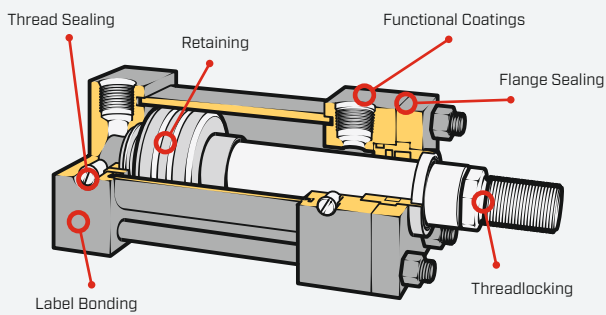
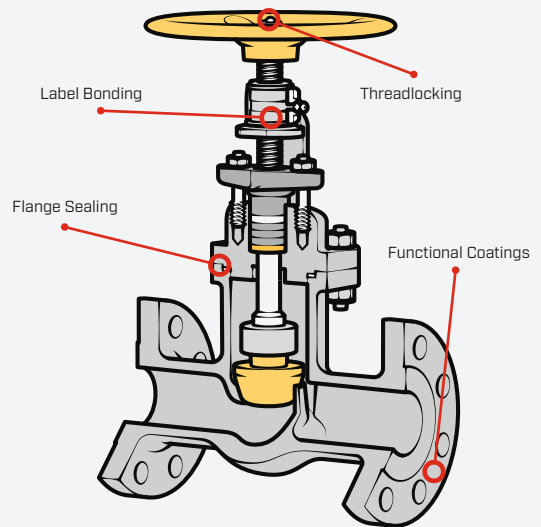
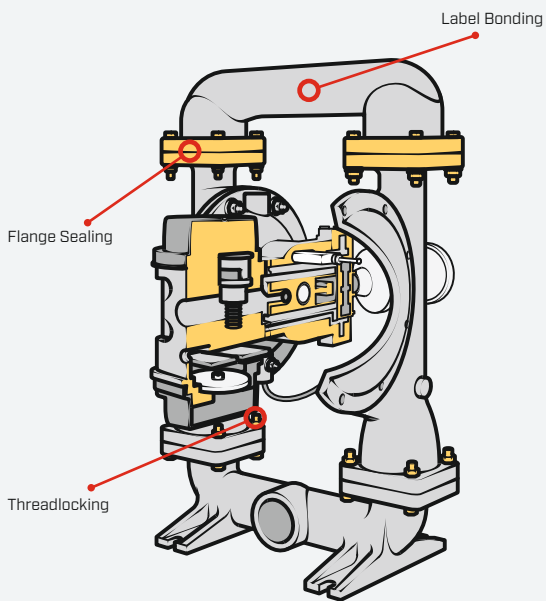
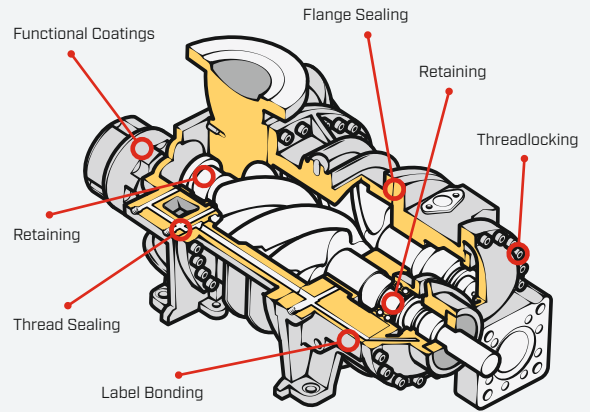
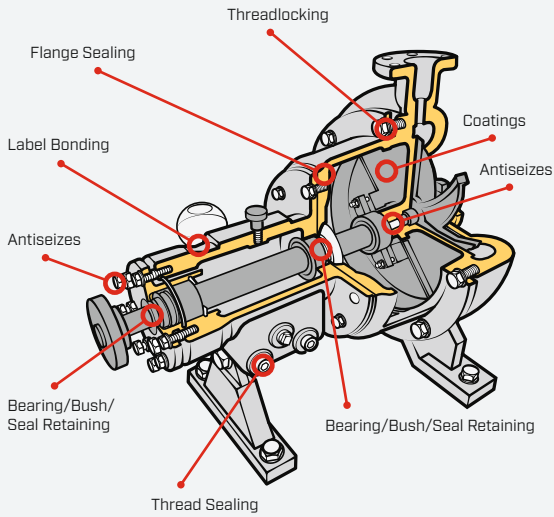

SPECIFIC SOLUTIONS FOR MACHINERY ASSEMBLY

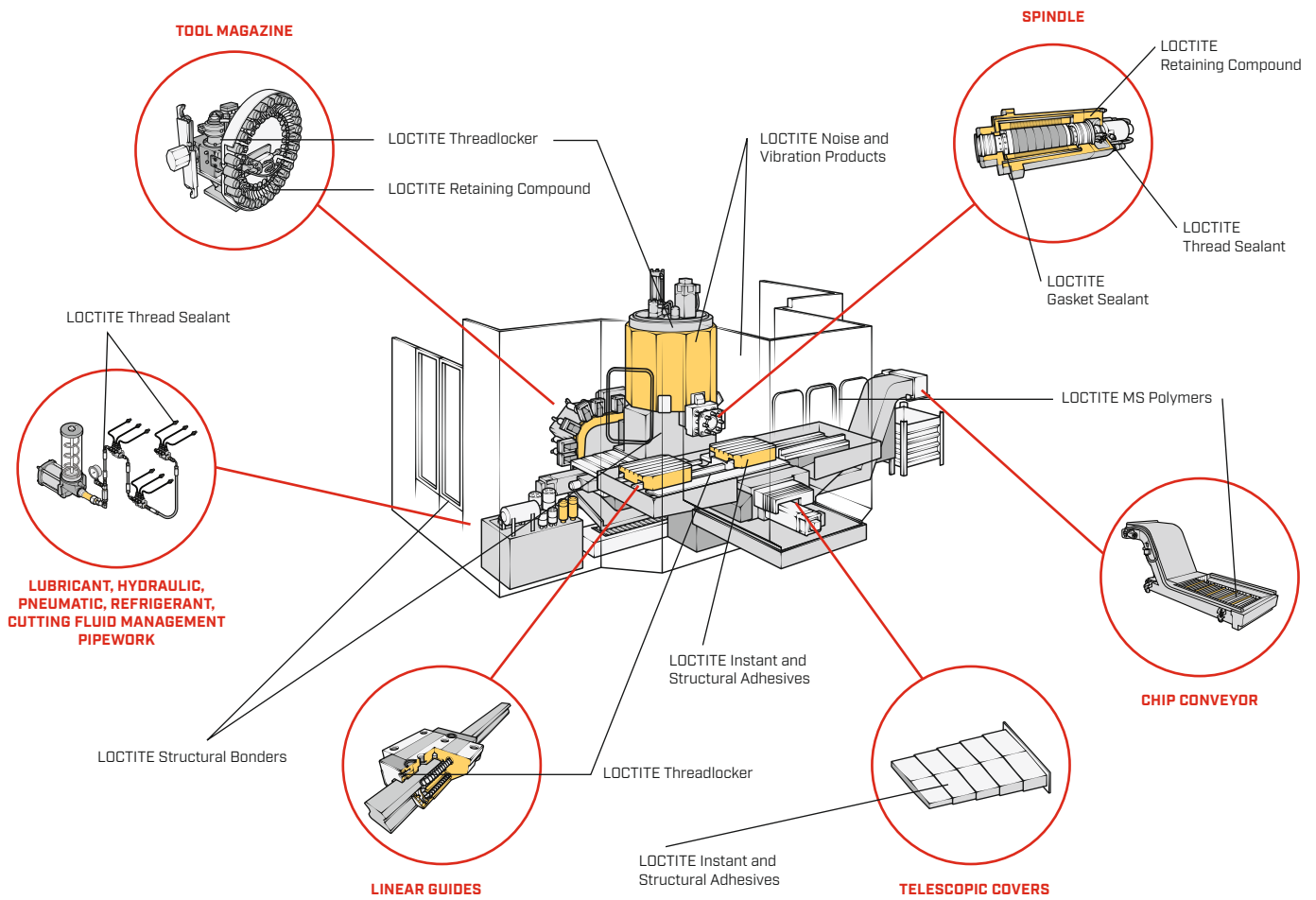

Improve your machinery, robots and automated lines.

- Incorporating new materials, new designs in guards, doors, windows and structures (e.g. bed and frame) to make them lighter while performing better
- Using much faster and more reliable sealing systems for all media and working conditions
- Reducing vibration and noise
- Improving the accuracy and reliability of the mechanisms (e.g. rollers, shafts, flanged couplings or bolted joints) with sustainable solutions
- Using faster and certified installation alternatives
- Introducing new faster assembly and maintenance operations (e.g. wear liners, sacrificial wearing coatings, rubber seals)

SPECIFIC SOLUTIONS FOR FACILITY ENGINEERING SERVICES

Facilities professionals in any industry can rely on.

LOCTITE adhesives, sealants, lubricants and other repair products to increase equipment reliability, reduce downtime, and minimise equipment failures.

	LOCTITE Liquid Thread Sealants	LOCTITE 55 Cord Sealant	PTFE Tape	Hemp and Paste
Vibrational Loosening Prevention	High (Joints locked)	Medium	Low	Medium
Chemical Resistance	Most fluids	Resists water & industrial gases. WRAS & DVGW approved	Most fluids	Industrial fluids
Requires Skilled Applicator	Easy to apply	Easy to apply	Requires expertise	Requires expertise
Allows Repositioning	Yes - whilst liquid No - when cured	Yes	No	Yes
Estimated Assembly Time per Joint	15-30 sec. (Cleaning included)	15-30 sec.	30-60 sec.	30-60 sec.

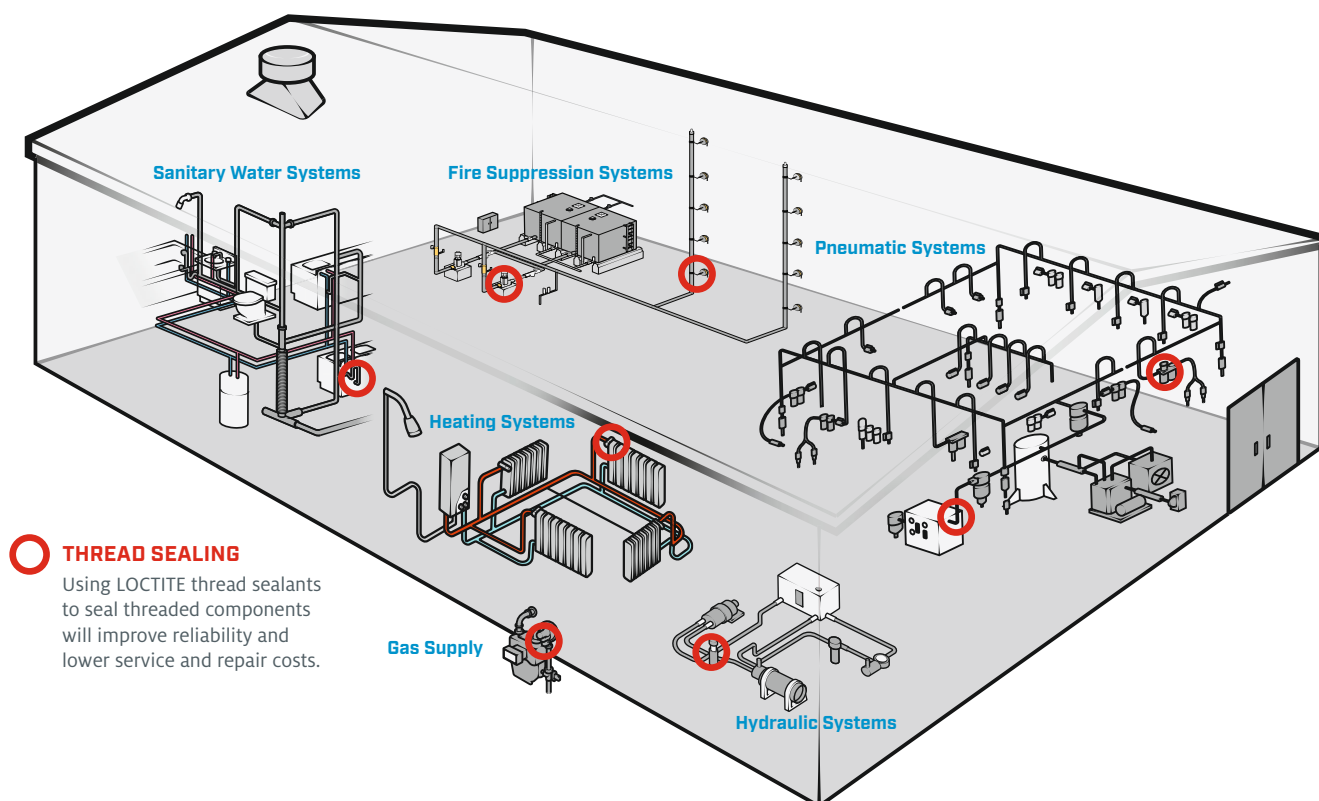



**To learn more about LOCTITE solutions for fluid processing, visit
www.henkel-adhesives.co.uk**

Henkel Ltd
Wood Lane End
Hemel Hempstead
Herts
HP2 4RQ

Tel.: (+44) 1442 278100

www.henkel-adhesives.co.uk

The data contained herein are intended as reference only. Please contact Henkel Technical Support Group for assistance and recommendation on specifications for these products.

Except as otherwise noted, all marks used above in this printed material are trademarks and/or registered trademarks of Henkel and/or its affiliates in the US, Germany, and elsewhere. © Henkel AG & Co. KGaA, 2018