

TANGIT PVC-C PLUS

PROPERTIES

- For bonding of thermoplastic PVC-C piping systems under pressure acc. EN ISO 15493.
- Open time of 2 minutes.
- Gapfilling and thixotropi.
- Improved structure for cleaner working.
- Tangit PVC-C PLUS complies with the requirements of EN 14814, Adhesives for thermoplastic piping systems for fluids under pressure.



AREAS OF APPLICATION

For bonding of PVC-C pressure piping systems acc. EN 14814 with diameter tolerances up to +0.6 mm and non-pressure piping systems according to EN ISO 15493 (PVC-C) and EN 1566.

TECHNICAL INSTRUCTIONS FOR USE

Preparation of pipes

If pipe ends and sockets have not yet been prepared according to the illustrations below, they must be chamfered and deburred. No tight and durable bond can be produced unless pipes have been properly chamfered.

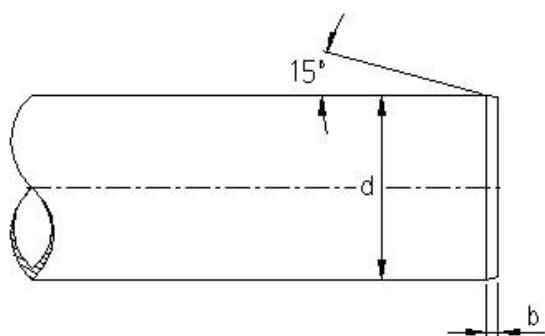

Pipe outer diameter d (mm)	Dimensions b about (mm)
up to 16	1-2
20-50	2-3
63-225	3-6

Pretreatment

Remove heavy dirt adherent to the surfaces to be bonded (pipe end outside, socket inside). Then measure the fitting insertion depth (= bond length) and mark it on the pipe end so that the application of the required amount of adhesive and the complete insertion of the pipe can be checked.

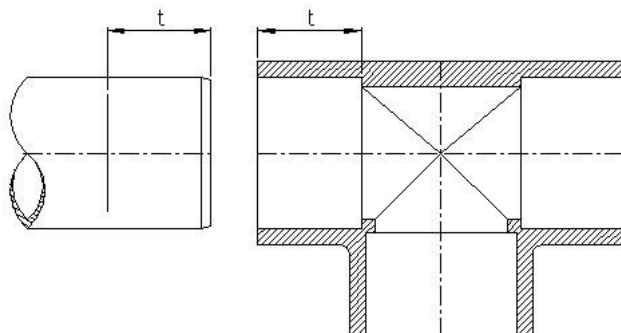

Outside pipe diameter \varnothing (mm)	16	20	25	32	40	50	63	75	90	110	140	160	225
Insertion depth t (mm)	14	16	19	22	26	31	38	44	51	61	76	86	119

Final cleaning is done using Tangit Cleaner & Primer PVC-U/C/ABS. Spray the cleaner onto white tissue paper and thoroughly clean the dry surfaces to be bonded so that they are free of dirt and grease. Use a new piece of tissue paper for each cleaning operation. The cleaned surfaces must be dry before applying the adhesive. Any ice must be removed by careful heating.

Application

Stir Tangit PVC-C PLUS well before use. Due to improved structure for cleaner working, the flow behaviour of Tangit PVC-C PLUS is different to common solvent based adhesives. The adhesive has a jelly structure and do not form a trail, flowing off a stick. In an axial direction apply a uniform coat of adhesive - first to the inside of the socket, then to the pipe. Apply thinly inside the socket in order to avoid the detrimental formation of beads inside the pipe but apply generously to the pipe end.

Tangit PVC-C PLUS is able to bridge gaps (caused by pipe tolerances) of up to +0.6 mm in compliance with EN 14814.

Recommended brush sizes:

d32	8 mm round brush
d40 - d63	1"-flat brush
d75 - d160	2"-flat brush
d225	2.5"-flat brush

Immediately insert the pipe into the socket to stop resp. to full depth, without twisting or jamming. Hold fast for several seconds until the adhesive begins to dry. From d160 upwards, insertion is facilitated by using a pipe joiner. Remove any excess adhesive with tissue paper immediately after joining. The components must be completely joined within the open time, i.e. the time from the start of adhesive application until joining the parts, which depends on ambient temperature and/or film thickness of the applied adhesive. The open time of Tangit PVC-C PLUS is 2



minutes at 20°C, with higher ambient temperatures the open time will decrease. From d75 upwards, the adhesive should be applied to pipe and socket simultaneously by two persons.

During the first 10 minutes after bonding, the pipes must not be moved. At temperatures below +10°C, this time must be extended to at least 30 minutes. Wait 24 hours after the last bonding before filling the pipes or performing leak tests (up to a test pressure of 1.5 x PN). If the pipeline is to be charged with the operating pressure, a minimum waiting time of 1 hour per bar must be observed. If lines are not to be operated immediately, it is recommended to flush them thoroughly. Leave them filled with water and flush them periodical.

General information

Before start of operation, pipelines must be thoroughly flushed in order to remove residual solvent vapours. Tangit PVC-C PLUS is ready for use and must under no circumstances be diluted. Tangit PVC-C and Tangit Cleaner & Primer PVC-U/C/ABS affect PVC-C. Pipes and fittings should therefore not be exposed to spilled adhesive/cleaner. Tightly close containers no longer in use in order to avoid solvent evaporation and thickening. Remove the skin of dried-up adhesive. Strip off thickened adhesive adherent to the brush with dry tissue paper. Cleaned brushes must be dry prior to further use.

Installation

Installation at low temperatures requires utmost care. At temperatures below +5°C, pipes and fittings tend to be more vulnerable to impact (embrittlement). Long-term exposure to solvent vapours (as may occur during the drying phase when the pipeline is closed) may therefore result in damage to the system. Since Tangit PVC-C PLUS cures physically by evaporation, hardening may be slowed down considerably. Special installation techniques are therefore required at temperatures below +5°C. For this purpose, pipe ends and sockets to be bonded are warmed to +25 to +30°C by means of a suitable hot-air blower (explosion-proof) and then bonding is done as described above. The finished joint must be kept at +25 to +30°C for approx. 10 minutes.

The installation of pressure pipes and fittings made of PVC-C requires expertise in the use of these materials. The instructions given here are therefore only meant to support well-trained staff in their work. Please make sure to observe the installation instructions of the pipe and fitting manufacturers

TECHNICAL DATA

Composition	Solvent-containing adhesive based on Methylethylketone
Heat resistance	Corresponds to that of PVC-C
Open time	2 minutes
Application temperature	5°C-35°C
Consumption	See table below
Final strength	24 hours
Shelf life	24 months



OTHER INFORMATION

Consumption:

For the production of one bonded joint the following **approximate** amounts of adhesive and cleaner are required:

Pipe dimension d (mm)	20	32	50	63	75	90	110	140	160	200	225
Tangit Adhesive (g)	3	5	9	15	20	36	60	90	120	200	300
Tangit Cleaner (ml)	3	5	9	11	13	14	17	21	25	45	65

Please note: The adhesive amounts indicated above are maximum values based on laboratory experience.

The actual consumption in a given application depends on working method, pipe gap and temperature.

LIMITATIONS

Storage

For practical reasons, Tangit should not be stored at temperatures below +5°C since this leads to a higher viscosity and thickening of the adhesive, thus affecting its workability. After conditioning at room temperature and thorough stirring, the temperature-induced viscosity increase and thickening is reduced again.

If stored at +20°C in unopened original can, shelf life is 24 months. Use before date and batch number are indicated on the packaging.

HEALTH AND SAFETY

Before using the product please see related Material Safety Data Sheet.

Tangit adhesives and Tangit cleaner are flammable. Solvent vapours are heavier than air. They may accumulate at ground level and form explosive mixtures. Therefore ensure sufficient airing and ventilation during application and drying. No smoking and no welding in the working area and in the rooms adjacent to it! No open light or fire, avoid any sparking or static charge! Accumulated solvent vapours and explosive mixtures must be removed prior to welding. Fill the pipes with water, flush and purge them well. Do not close / seal the pipes while drying. Prolonged inhalation of solvent vapours may be injurious to health. In order to minimize exposure to solvent vapours, keep used tissue paper in closed containers (e.g. buckets with lids). As precaution, protective gloves should be worn to avoid skin contact and maximum cleanliness should be observed (repeatedly wash hands during work and use a greasy skin cream or emulsion).

In case of contact with the eyes, rinse thoroughly with water and obtain medical advice. Immediately take off any clothing stained with adhesive.

Never use PVC piping systems with compressed air or gas!



For further information refer to the leaflets and accident prevention regulations of the employers' liability insurance associations and the safety data sheets. Detailed information on safety requirements and workplace hygiene in connection with Tangit can be found in the leaflet "Working with Tangit".

DISPOSAL

Product remains must be disposed of as special waste. Only recycle well-emptied containers with dried-up adhesive residues and free of solvent vapours.

"The information provided in this Technical Data Sheet (TDS) including the recommendations for use and application of the product are based on our knowledge and experience of the product as at the date of this TDS. The product can have a variety of different applications as well as differing application and working conditions in your environment that are beyond our control. Henkel is, therefore, not liable for the suitability of our product for the production processes and conditions in respect of which you use them, as well as the intended applications and results. We strongly recommend that you carry out your own prior trials to confirm such suitability of our product. f.

Any liability in respect of the information in the Technical Data Sheet or any other written or oral recommendation(s) regarding the concerned product is excluded, except if otherwise explicitly agreed

Henkel AG & Co. KGaA

Henkelstr. 67, D-40589 Düsseldorf, P.O. Box, D-40191 Düsseldorf

Phone: +49 (0) 211 / 797-0

Internet: www.tangit.com