

LOCTITE®

HOW TO INCREASE RELIABILITY
**AND PREVENT THREADED
ASSEMBLY FAILURE**



LOCTITE® is the registered trademark of Henkel IP & Holding GmbH.
All other marks are the trademarks and service marks of their respective owners.
No part of this book may be reproduced without prior permission of Henkel.
©2020 Henkel Corporation. All rights reserved.

CONTENTS

1	Foreword	6			
2	Introduction	8			
3	Definition of an adhesive	12			
4	History of adhesives and threadlockers	14			
5	The basics of adhesives	18			
5.1	The basics of bonding	19			
5.2	Adhesion	19			
5.3	Cohesion	19			
5.4	Understanding the bonding process	20			
5.4.1	Overview of the bonding process	20			
5.4.2	Surface preparation	20			
5.4.2.1	Cleaning	22			
5.4.3	Application of product	25			
5.4.4	The curing process	26			
5.4.5	Performance and testing of cured adhesive	28			
5.4.5.1	Cured adhesive strength	29			
5.4.5.2	Effect of environment on cured bondline	29			
6	Threaded assemblies	30			
6.1	Threaded fastener mechanics	31			
6.1.1	Inclined plane	33			
6.2	Getting the right clamp load	36			
6.3	Controlling clamp load	37			
6.3.1	Determining the k-factor	40			
6.3.2	Mathematics of bolt tightening	40			
6.3.3	Influencing factors in achieving correct clamp load	45			
6.4	Fastener failures	50			
6.4.1	Common myths about threaded fasteners	50			
6.4.2	Why threaded assemblies fail	50			
6.4.3	Traditional mechanical methods to prevent failure	58			
6.4.3.1	Preventing relaxation	60			
6.4.3.2	Preventing self-loosening	60			
6.5	Threadlockers	65			
6.5.1	The LOCTITE® Threadlocker solution	65			
6.5.2	Anaerobic cure mechanism	69			
6.5.3	Factors influencing anaerobic curing	70			
6.5.3.1	Substrates	71			
6.5.3.2	Temperature	74			
6.5.3.3	Gap between substrates	74			
6.5.4	Surface preparation for threadlockers	75			
6.5.4.1	Chemical preparation - activators	77			
6.6	Applying the product	78			
6.6.1	Properties of threadlockers	80			
6.6.1.1	Uncured threadlocker properties	80			
6.6.1.2	Cured threadlocker properties	81			
6.6.2	Assembly validation	86			
6.7	Validation of assemblies	90			
7	Dispensing	92			
7.1	Why dispensing equipment?	93			
7.2	Dispensing technology	94			
7.2.1	Pressure/time dispensing	94			
7.2.2	Volumetric dispensing	96			
7.2.2.1	Peristaltic pump	96			
7.2.2.2	Progressive cavity pump	97			
7.3	Manual dispensing	99			
7.3.1	Manual hand pumps	99			
7.3.2	Benchtop digital peristaltic dispenser	99			
7.3.3	Controller/reservoir with valve	100			
7.4	Automated dispensing	101			
7.4.1	Automated time/pressure system	102			
7.4.2	Automated volumetric system	104			
7.5	Equipment selection	104			
8	Troubleshooting	106			
8.1	Failure mode analysis	107			
8.2	Root causes	109			
9	Shelf life	110			
10	Certifications and standards	112			
10.1	Product certifying organizations	113			
10.2	Test standards	113			
11	Appendix	114			
11.1	Contact	115			
11.2	Chemical compatibility chart	115			
11.3	Unit conversion table (imperial/metric)	125			
11.4	Volume calculation	126			
11.5	Technical information: Standard test methods for threadlocker testing	126			
11.5.1	ISO 10964 adhesives	126			
11.5.2	ISO 10123 adhesives	127			
11.5.3	ISO 16047 assembly	128			
12	Bibliography	132			

LOCTITE[®]X

Get even more out of your
LOCTITE[®] experience with **LOCTITE[®]XPLORE**

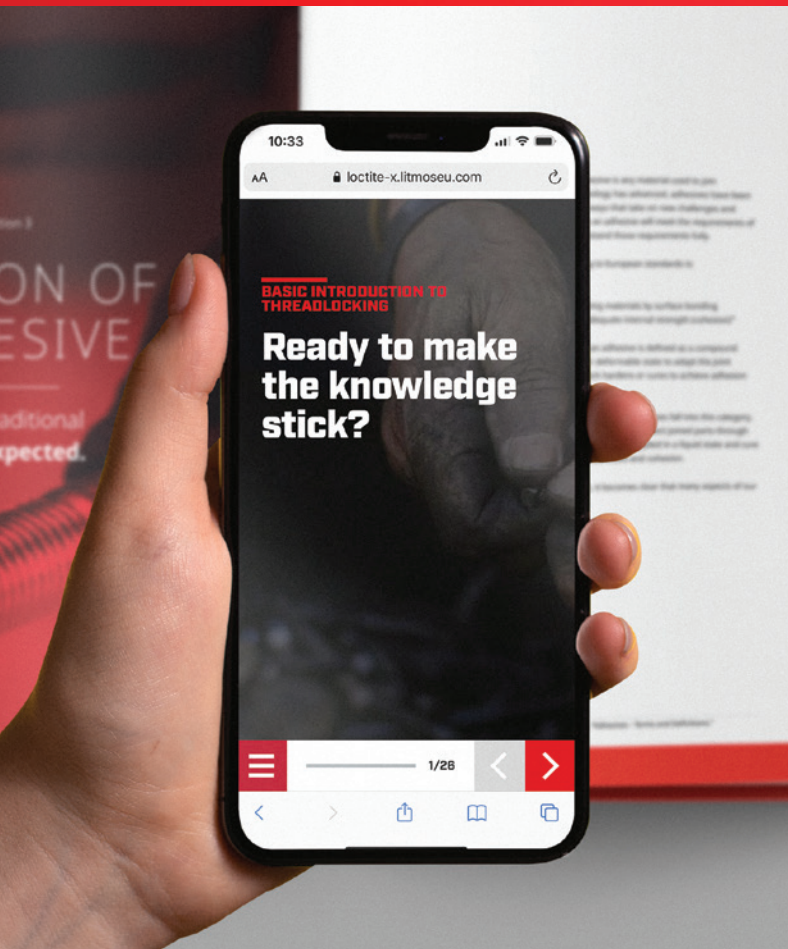
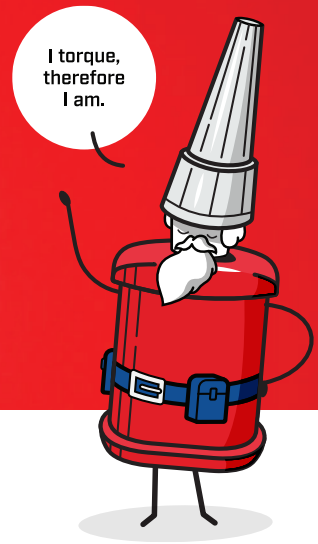

See what our first learners had to say:

"The best ever LOCTITE[®] App I have seen."

- Terry K.

"This interactive training is fantastic!"

- Danny C.

Want an even richer experience from this module? We're pleased to introduce you to LOCTITE^{®XPLORE}, our new e-learning platform designed for Assembly, Maintenance and Vehicle Repair Pros. LOCTITE^{®XPLORE} brings to life our LOCTITE[®] expertise in online learning modules. In our Threadlocking e-learning course, you will access additional knowledge, tools, how-to videos & live quizzes. You'll also meet Loc, our character who helps you make sure the knowledge sticks!

It's 100% free and fun. Each chapter is around 15 minutes. Once you've completed the course, we'll send you a digital LOCTITE[®] certificate !

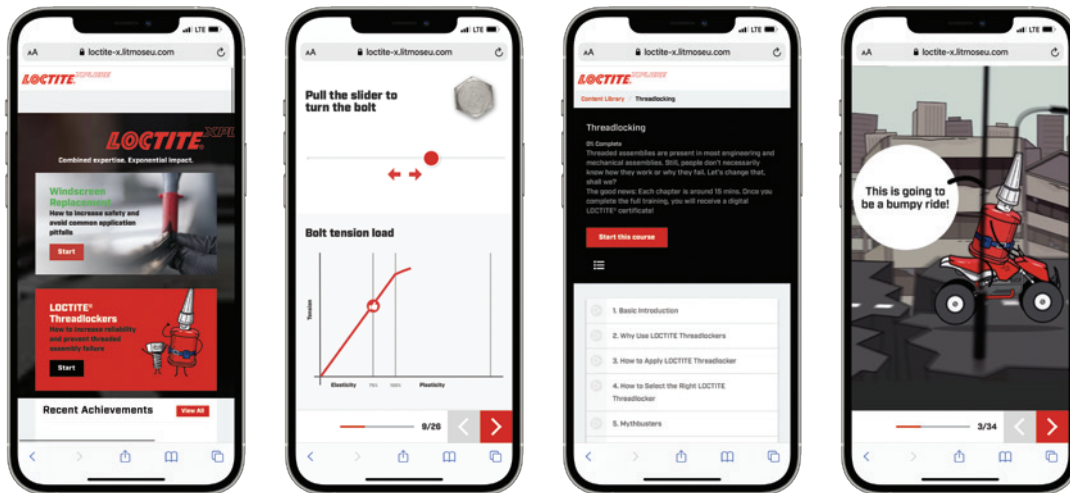

Getting started is fast and easy.
First, just register here:

Using your smart phone, scan here.



Having trouble with our QR code? Visit loctitexplore.com on your mobile device.

Look for the above QR code, it will be inserted throughout the module, where you can access additional knowledge, videos and demo tools on LOCTITE^{®XPLORE}.

Get certified now!



Section 1

FORWARD

Combined expertise.
Exponential impact.

In 1876, Fritz Henkel's love for science led him to recognize the need for a universal detergent based on silicate. From that day forward, Henkel's focus on solving customer challenges has helped us build a vast body of expertise as a global manufacturer of adhesives, laundry products and beauty care products. LOCTITE®, one of Henkel's flagship brands, reflects and drives much of that expertise. As the global leader in adhesives and sealants, our footprint in over 120 countries and our passion for solutions that help unlock the limitless potential of man and machine allow us to provide you, our customer, the local support you need to solve your maintenance and design challenges. Our global leadership position in the adhesives market could not have been achieved without the expertise, dedication and knowledge of LOCTITE® and our technical teams across the globe.

It also could not have been achieved without you, our customers. By inviting us into your challenges and embracing our solutions, you have helped us help you. Through our work for you, we have developed market-, industry- and technology-specific expertise that we put back to work for you. Many customers have commented on the expertise of the LOCTITE® teams they interact with. The compliment is well-earned, as our people include many patent holders and members of certification bodies. They are some of the finest minds in industry.

Now, just as you have enabled us to build our expertise, we want to empower you. While the expertise of our technical teams is a source of great pride to us, our greater goal is to help you solve your technical challenges by providing insight into adhesive technologies. This module, and our larger collection on our adhesive technologies and applications, is part of that effort.

We are proud to share our expertise with you—the expertise you have helped us build—in this module and, of course, in our face-to-face interactions. We hope the learning we've assembled here will help you make your machines more powerful, durable and efficient, and we look forward to helping you solve your challenges in the near future!

With pride and gratitude,



Dr. Nigel Fay
*Henkel Corporate Director
Product Development,
Engineering & Technical Service*

A handwritten signature in black ink that reads "Nigel Fay".



Dr. Kourosh Bahrami
*Henkel Corporate
Vice President*

A handwritten signature in black ink that reads "K. Bahrami".



Section 2

INTRODUCTION

Thank you for taking an interest in understanding threaded fasteners and threadlocking applications. Our goal with this book is to help you make informed decisions that improve the efficacy of bolted joints within assemblies and keep plant operations running smoothly and efficiently. By making our technical and scientific knowledge available, we hope to help you overcome design challenges, reduce scrap and increase the reliability of bolted joints. Ultimately, our hope is that you will use this expertise to overcome a wide range of engineering and maintenance challenges.

The content you'll find here explores adhesives and the development of threadlockers, including how they work, then examines all kinds of industrial threaded assemblies, what makes them work and why they fail. Finally, it provides detailed information on threadlocker usage and application to help guarantee the best results.

This book is the culmination of our 65+ years as the original manufacturer of chemical threadlockers. As we have developed and manufactured chemical technology and built expert engineering and product development teams, we have learned how to help shape advancements in manufacturing and maintenance processes. Many of our team members were involved in the development of this book, and it would not have been possible without their contributions. A look at their backgrounds will make it clear why.



Michael Feeney

Senior Application Engineer

11 years at Henkel

Current Location: Toronto, Canada

Product Technology Expertise: Machinery adhesives, Structural adhesives

As an application engineer, Michael has had a focus on threadlocking technology throughout his career, supporting manufacturing and maintenance operations in the US and Canada. His extensive engagement with customers and their applications has made him a leading expert in North America on threadlocking and machinery adhesive applications. Michael holds a degree in Mechanical Engineering from the University of Ottawa.



Rudolf Neumayer

Sales Excellence and Training Technical Lead

32 years at Henkel

Current Location: Munich, Germany

Product Technology Expertise: Anaerobic machinery adhesives, Cyanoacrylates, Structural adhesives

Over Rudolf's 32 years with Henkel, he has become one of our leading technical experts in Europe, supporting both manufacturing and maintenance operations. He has helped troubleshoot and specify threadlocking applications across a broad range of industries, such as heavy duty equipment, powered drive systems, automotive powertrains and general industrial manufacturing. Rudolf holds an engineering degree in plastics technology.



Dr. David Condrón

Product Development Technical Lead—Machinery Adhesives

16 years at Henkel

Current Location: Dublin, Ireland

Product Technology Expertise: Anaerobic adhesives, Cyanoacrylates

David has a background in organometallic chemistry with a Ph.D. from University College Dublin. He has been involved in several product development roles in the chemical industry and has worked in the development of acrylate-based adhesives for the past 16 years. David currently leads a team involved in the development of new anaerobic products for various applications, such as threadlocking, thread-sealing, retaining and flange sealing. A key focus of his research efforts is the development of new sustainable high performance threadlockers designed to cure on many types of metal substrate.



Chulsoo Woo

Technical Training Manager, Asia Pacific

34 years at Henkel

Current Location: Shanghai, China

Product Technology Expertise: Anaerobic adhesives, Structural adhesives, Light cure adhesives

Chulsoo started his career with LOCTITE® in 1987 as the first technical service engineer in South Korea. He has assisted with the qualification and specification of LOCTITE® Threadlockers in numerous applications, including automotive drive trains, heavy duty machinery, railway, electric motors, loudspeakers and elevators, to name a few. Chulsoo continues to take pride in helping customers increase the reliability and performance of their assemblies in manufacturing and maintenance while helping to reduce costs.

'Anaerobics have been, and will continue to be in my DNA.'



Dr. Shabbir Attarwala

Scientific Fellow

33 years at Henkel

Current Location: Rocky Hill, USA

Product Technology Expertise: Anaerobic adhesives, Cyanoacrylate adhesives, Structural adhesives

Shabbir received a Ph.D. in Organic Chemistry from Polytechnic New York University, holds over 100 patents and has published dozens of technical papers and presentations.

As a leading expert in his field, he has mentored and trained a number of scientists in the Henkel community and has played a key role in establishing research and development teams in North America, Asia Pacific, India, the Middle East, Africa and Turkey.

Additional contributors

Anne Brown Technical Director	Rocky Hill, USA
Bob Orme Senior Technology Specialist	Hemel Hempstead, UK
Chetan Hire, Ph.D Senior Development Chemist	Rocky Hill, USA
David Gettleson Equipment Engineer, Technical Customer Services	Hemel Hempstead, UK
Laura Lamard Global Marketing Customer Activation Manager	Bordeaux, France
Oliver Droste Senior Application Engineer	Munich, Germany
Sandra Sabella Lab Operations Engineer	Rocky Hill, USA
Steve Rayner Global Innovation Project Manager	Dublin, Ireland



Section 3

DEFINITION OF AN ADHESIVE

From traditional
to unexpected.

The simplest definition of an adhesive is any material used to join components together. As technology has advanced, adhesives have been used in increasingly innovative ways that take on new challenges and replace traditional methods. To ensure an adhesive will meet the requirements of an application, it is important to understand those requirements fully.

The definition of an adhesive according to European standards is:

EN 923:2015

'non-metallic substance capable of joining materials by surface bonding (adhesion), and the bond possessing adequate internal strength (cohesion)'¹

From a Henkel technical point of view, an adhesive is defined as a compound applied to a surface in a liquid, paste or deformable state to adapt the joint geometry on one or both surfaces, which hardens or cures to achieve adhesion and cohesion.

Many things we would not traditionally consider adhesives fall into this category. Threadlockers fulfil both of these definitions; they connect joined parts through adhesion and exhibit cohesive strength. They are applied in a liquid state and cure between the joint geometry to achieve adhesion and cohesion.

When we understand these definitions, it becomes clear that many aspects of our lives are touched by adhesives.

1. European Committee for Standardization, "Adhesives - Terms and Definitions."



Section 4

HISTORY OF ADHESIVES AND THREADLOCKERS

A rich history and
a bright future.

The science has changed but humans have been toolmakers and adhesive makers since the earliest days of human development. Stone tools from the Paleolithic era, 40,000–75,000 years ago, were bonded to wood, antler and bone with organic resins such as pitch and bitumen. One of the best preserved examples we have of adhesive use in tools is the Ötzi Axe² pictured in Figure 1.



FIGURE 1
A reconstruction of Ötzi's axe, which used pitch as an adhesive, 3400–3100 BCE.

Throughout the Industrial Revolution, the focus of manufacturing was volume: how many assemblies could be manufactured in the shortest time. Today's manufacturing and assembly industries also search for methods that allow for faster production while increasing the reliability of their products. Adhesives have and will continue to play a role in increasing efficiency and reliability.

In 1945, two GE chemists, Birger Norlander and Robert Burnett, discovered a material which they called 'anaerobic permafил'. They found that when they synthesized tetraethylene glycol dimethacrylate, heated it to between 65°C and 75°C (150°F–170°F), and bubbled air through it, an oxygenation reaction took place. When the liquid cooled, it would remain liquid for months, as long as aeration was continued as a bubbling air stream through the liquid at room temperature. When the air was turned off, the material would set up to a solid, highly crosslinked resin within minutes.²

In 1953, a stable formula and a practical application for Norlander and Burnett's discovery was developed. American professor Vernon K. Kriebel developed an anaerobic threadlocking adhesive in his basement laboratory at Trinity College in Hartford, Connecticut.

Kriebel's company, American Sealants, founded the LOCTITE® brand, a name chosen by Kriebel's daughter-in-law, Nancy Brayton Kriebel, and registered as the official trademark in 1956.³

2. Degano, *Hafting of Middle Paleolithic Tools*.

3. Grant, *Drop By Drop*, 17, 19, 21.

Section 4: History of adhesives and threadlockers

Sealant made its official public debut at a press conference at the University Club of New York on July 26 of that year, and a new era of mechanical reliability was ushered in with a solution that prevented vibrational loosening of mechanical fasteners, a frequent cause of machine failure. Since then, Anaerobic Technology has found applications in all market segments across manufacturing and maintenance. Key application areas include threadlocking and threadsealing, retaining, sealing, gasketing, flange sealing and structural bonding.

In 1963, American Sealants changed its name to the LOCTITE® Corporation. After Vernon Krieble's death in 1964, his son Robert H. Krieble, also a chemist, served as chief executive until 1985. In 1997, LOCTITE® was acquired as a flagship brand by the Henkel Corporation, a Fortune 500 company headquartered in Dusseldorf, Germany. Since then, LOCTITE® has remained a primary Henkel brand, providing solutions for many bonding, sealing and coating challenges. In recent years, the company has increased its focus on green and sustainable technologies.⁴

FIGURE 2 (LEFT)
Vernon K. Krieble, developer of the the first anaerobic threadlocking adhesive.



FIGURE 3 (RIGHT)
The original location of American Sealants Company, which would eventually become LOCTITE®.



4. Henkel. *History*, 2020.

A rich history and a bright future.



Section 5

THE BASICS OF ADHESIVES

building the foundation of
adhesive principles.

The basics of bonding

5.1

Today, adhesive bonds can be found in nearly every object around us, from shoes to smartphones, from toys to aircraft. Adhesives join surfaces through a chemical reaction that involves a paste or liquid curing to a solid. Curing may be initiated by several factors, including temperature, moisture, the presence of a catalyst or, in the case of threadlockers, a lack of oxygen. Once cured, adhesives exhibit two key characteristics that are important to differentiate: adhesion and cohesion. The combination of adhesion and cohesion in bonded assemblies enables a joint to withstand external loads.

Adhesion

5.2

Adhesion is an interaction between a substrate and an adhesive where the two meet. Two types of interaction result in good adhesion: one is a molecular interaction (for example chemical bonds, 'Van der Waals' forces), and the other is a mechanical interlocking called 'mechanical keying' in the assembly. The adhesive applied to the substrate flows into the valleys of the surface and, once cured, grips the surface. Molecular interactions on the other hand, rely on electron sharing/transfer or attractive forces between charged molecules at the interface.

Cohesion

5.3

Cohesion is an interaction between the molecules of a substance within an adhesive. This is a combination of 'Van der Waals' forces and covalent bond forces in the adhesive molecules. The material properties of an adhesive are defined by the cohesive strength and are independent of the adhesion strength between the adhesive and the substrate.

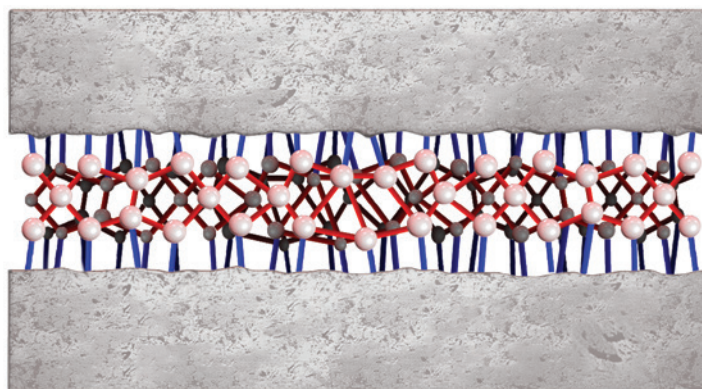

● Adhesive molecule — Cohesion — Adhesion

FIGURE 4
Adhesion and cohesion.

5.4

Understanding the bonding process

5.4.1

Overview of the bonding process

Each aspect of the bonding process requires the examination and control of a number of factors, but first we must understand the four main stages of the bonding process, as shown in Figure 5.

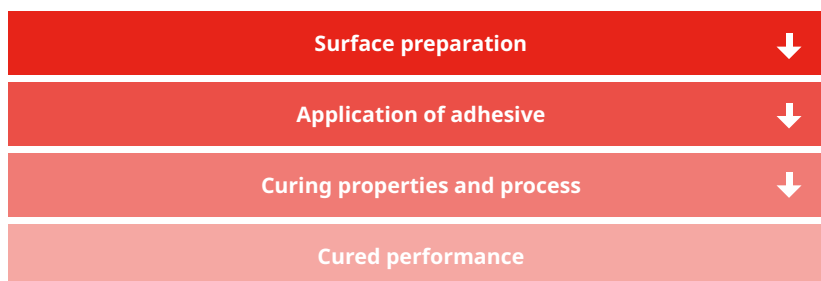

FIGURE 5
Overview of a typical bonding process.

5.4.2

Surface preparation

The adhesion properties of a bond joint are significantly influenced by the surface characteristics of the substrates. Proper cleaning and pre-treatment steps are necessary to achieve the strongest adhesive bonds (see Figure 7).

Adhesion is improved by:

- Removing unwanted surface films by degreasing or mechanical abrasion
- Activating the surface through the use of a primer
- Changing the surface activity by etching, corona treatment, low plasma treatment, etc.

In order to achieve the optimal mechanical, thermal and chemical performance of an adhesive, the bond surface must be free of contaminants that may affect adhesion to the substrate.

SOURCE OF CONTAMINATION	CONTAMINATION
Manufacturing process	Release agents, graphite content in cast iron, drawing lubricants
Handling	Oils
Environment	Moisture, dirt and dust
Machining processes	Cutting fluids, swarf, corrosion inhibitors
Inactive layers	Oxide layers (metals), protective oil, e.g. black oxide steel bolts
Residues from galvanic processes	Metallic protective coatings like Zinc, Nickel, Phosphate or Chromate
Cleaning processes	Residues from alkaline baths or industrial cleaners, corrosion inhibitors

TABLE 1
Sources of contamination.

Depending on the type of contaminant, it can be removed effectively by using the appropriate aqueous-based or solvent-based cleaners.

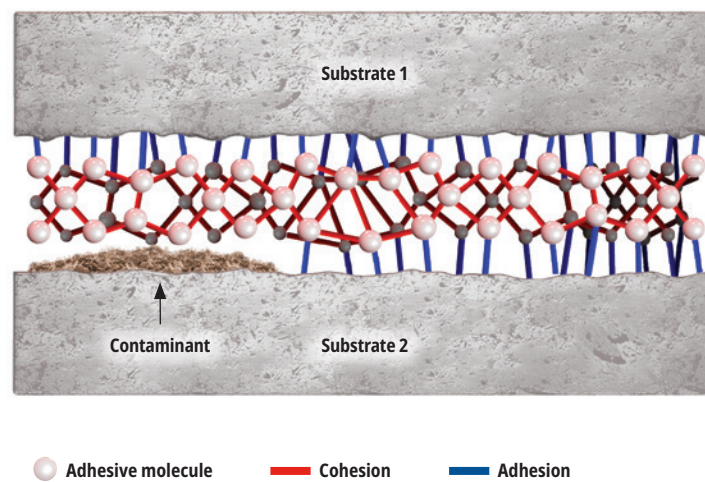

FIGURE 6
Contaminant on substrate surface affecting adhesion.

Cleaning

It's important to clean parts shortly before the adhesive is applied to ensure a contaminant-free surface. Parts that are cleaned far in advance of adhesive application may become re-contaminated prior to bonding if, for example, they are handled with bare hands, gather dust or are exposed to corrosion caused by humidity.

When addressing contamination and selecting the correct cleaner, there are a number of factors to consider: type of contaminant (inorganic/organic), polarity of contaminant, substrate compatibility, part geometry, health and safety regulations and type of process to be used.

Aqueous-based cleaners

Aqueous, or water-based cleaning is mainly used when large parts or large quantities of parts are cleaned in one bath process. For optimal performance, aqueous cleaning is usually done at temperatures of 60°C–80°C (140°F–176°F) with a specified immersion interval. The parts should then be rinsed with demineralized water to prevent mineral deposits, which may affect adhesion. Aqueous cleaners almost always contain corrosion inhibitors, so testing for compatibility with the adhesive is recommended.

Considerations regarding the use of aqueous cleaners are the significant drying time required, the added energy required to speed the drying process, flash rust and maintaining the bath solution. Another possibility is to add solvents to the cleaner, which reduces the cleaner's evaporation time.

Solvent-based cleaners

Solvent-based cleaning processes usually involve dip baths, closed solvent steam chambers or manual wiping processes (which are most commonly used to clean low volumes of assemblies immediately prior to bonding). Metallic swarf and inorganic components cannot be removed by solvent-based cleaners. However, if oil or grease (such as cutting fluid) is causing the inorganic soils to adhere to the surface, solvent-based cleaners are effective because they cause contaminants to lose their adhesion to the surface.



	SOLVENT-BASED CLEANER	AQUEOUS-BASED CLEANER
	Ideal prior to bonding	Dilution in water
	No residues left on substrate	Biodegradable
	Impurity dilution (oil, etc.)	Cleans organic and inorganic impurities
	Immediate evaporation	Compatible with most substrates
	Good for manual cleaning processes	No offensive smell
	Can attack plastics (e.g. stress cracking)	Need to mix and monitor specific concentration
	Does not clean inorganic impurities (e.g. salt)	Leaves surface residue, which can affect bonding. Needs rinse stage
	May have flammable labeling	Flash rust
	Contain VOCs (regulatory considerations)	Need to monitor contamination of wash solution

TABLE 2
Comparison of aqueous and solvent-based cleaners.





















SOLVENT-BASED CLEANERS			
CONTAMINANT	HYDROCARBONS	ALCOHOLS	KETONES, ESTERS
Cutting fluid			
Corrosion inhibitor			
Waxes			
Lubricants			
Liquid resins			
Liquid adhesives			
Fingerprints			
Silicone oil			
Release agent			

TABLE 3
Efficiency of solvent-based cleaners on contaminants.



-  Recommended cleaning agent
-  Acceptable cleaning agent
-  Not recommended as cleaning agent

TABLE 4
Efficiency of aqueous-based cleaners.

AQUEOUS-BASED CLEANERS			
CONTAMINANT	ALKALINE pH 9-14	NEUTRAL pH 4-10	ACIDIC pH 0-4
Cutting fluids	●	●	✓
Greases	✓	●	✓
Emulsions	✓	●	✓
Deep drawing oil	✓	●	✓
Deep drawing soap	✓	✓	✓
Hard oils	⊖	●	●

- ✓ Recommended cleaning agent
- Acceptable cleaning agent
- ⊖ Not recommended as cleaning agent

A good cleaner should remove all contaminants with one cleaning stage and dry quickly at room temperature without leaving residues. It must comply with health and safety standards of the region. User safety and environmental concerns regarding volatile organic compounds (VOC), biodegradability and other considerations should be taken into account. Finally, care should be taken to use a cleaner that does not attack the substrate the way solvents, for example, can crack or soften plastics and some alkaline cleaners may aggressively attack aluminium.

TABLE 5
Cleaning application details and considerations.

APPLICATION DETAIL	IMPORTANT CONSIDERATIONS
Type of contamination	The cleaner should be selected based on the chemistry of the contamination: polar/non-polar, inorganic/organic.
Process	To eliminate any residue being left behind on the surface, most cleaners need time to evaporate the carrier solution prior to bonding. It is also important to consider what type of cleaning process will fit best in a process (dip tank, spray, wipe).
Parts being cleaned	The cleaner must be compatible with the parts to ensure it will not negatively impact them.
Health and safety of operations	Cleaners should comply with health and safety standards to protect workers and the environment.



FIGURE 7
Cutting fluid during drilling operations may affect cure of anaerobic adhesives (threadlockers).

Application of adhesive

5.4.3

For optimal adhesive performance, the correct application is very important. For example, surfaces must be completely wetted with adhesive, and the position of the part and the gap of the desired bond also need to be considered. Vertical or horizontal positioning of the parts will dictate the dispensing methods and the ideal rheology.

Rheology: Viscosity, shear thinning, thixotropy

To select the best adhesive for a specific application, rheological properties such as viscosity, shear thinning and thixotropy need to be considered.

Viscosity is the internal resistance of a substance against a deformation caused by an external force. Some adhesives flow very easily, whereas other types of adhesives are so thick, they hardly flow at all. High viscosity essentially means a lot of force is needed to make it flow.

Thixotropy, or shear thinning, is the behaviour of fluids whose viscosity decreases as shear strain increases. Shear thinning is the most common type of non-Newtonian behaviour of fluids and is seen in many industrial and everyday applications. It is generally observed in polymer solutions (such as adhesives) and molten polymers, as well as in complex fluids and suspensions, such as ketchup, whipped cream, blood, paint and nail polish. Once the shear load is stopped, the liquid returns to its original viscosity.

Dispensing adhesives

There are a variety of options available for dispensing adhesives, from fully manual to fully automatic and everything in between. **Before selecting a dispensing method, consider these three factors:**

- Chemistry type
- Process requirements
- Package size

In many cases, these factors may be dependent upon each other; for example, chemistry stability may dictate package size and vice versa. Together, these three factors determine which equipment can be used to dispense an adhesive, and equipment is only chosen after these factors are thoroughly evaluated. Dispensing is discussed in greater detail in section 7.

5.4.4

The curing process

Most adhesives go through a curing reaction and transition from a liquid or paste to a solid polymer. There is a direct relationship between the curing action and the development of adhesive strength. Adhesive cure speeds vary greatly from hours to days and will typically be stated on a technical data sheet. Handling time, which is part of the overall cure time, is the time required for partial strength that allows a part to be moved to the next step in a process. Handling strength must be determined by the user based on the assembly process. Cure time is a longer period and is the time required for full or close to full strength. Cure speed can vary with many different factors, such as ambient conditions, catalysts, substrates, gap and the use of activators.

Maximum performance from the final cured adhesive is achieved by understanding the factors that affect cure and by mitigating any potential negative influences, such as cure inhibitors, insufficient mixing or environmental factors like temperature and relative humidity.

Bonding process requirements

In a bonding process, the cycle time and the number of pieces to be bonded are determining factors. Cure speed, fixture time, handling strength and clamping time are also considerations. Manner of application, for example dispensing of beads, dots and films, is determined by the viscosity and the flow behaviour of the adhesive. The number of bonding positions or process lines is determined by how long the bonded parts must be clamped before they can be moved from one station to another station. In automated processes, in-line monitoring is used to check whether the adhesive has been dispensed, for example, by scanning for a fluorescent substance in the adhesive.

Fixture time

There are several laboratory tests to measure fixture time. One such test defines it as the time needed for a standardized bond to reach a shear strength of 0.1 N/mm² (14.5 psi). Fixture time should not be confused with handling time, which is specified for each application individually.

The cure development profile is also commonly displayed on Henkel technical data sheets, represented in a graph of strength build over time. It is important to consider that any standardized test and cure speed will likely be impacted by factors such as substrate and ambient conditions.

Open time

Open time is defined as the maximum time from when the adhesive has been mixed (two-component), activated or applied and when parts can be assembled.

Full cure time

Full cure time is the time interval required for an adhesive to reach its full strength. A fully cured adhesive has achieved its intended mechanical and physical properties, like resistance to external forces and resistance to chemicals and thermal aging. The final strength is indicated in technical data sheets through various test methods and it will be dependent on gap size, environmental temperature and chemicals contacting the adhesive joint.

Cure temperature

Temperature is one of the most important variables when considering adhesive cure characteristics, as the cure speed will be inversely affected by a rise or fall in temperature. A general rule is: for every 10°C (18°F) that the temperature increases, the stated time required for the adhesive to cure will be halved. Conversely, a reduction in temperature of 10°C (18°F) will double the stated cure time. Depending on the chemistry, a point will be reached where curing has nearly stopped.

Many adhesives cure fully at room temperature (23°C, 73°F). However, higher curing temperatures cause faster cross-linking of adhesive molecules and a higher grade of cross-linking. In general, lower curing temperatures lead to a slower cure speed and a lower cross-linking.

Humidity

Some adhesive chemistries are moisture curing and rely on atmospheric humidity. An increase in humidity levels or a substrate with high moisture content will increase the rate of cure for these adhesive types. One caveat for moisture-curing adhesives is that increasing the temperature with the intention of speeding the cure time may have the opposite effect if the humidity is reduced.

Exotherm

Some adhesive curing results in an exothermic chemical reaction. Faster curing adhesives and larger adhesive masses will result in higher exotherm temperatures. The shape of the adhesive mass and the thermal conductivity of the substrate also play significant roles: a thin layer of adhesive over a large metal surface area will have a much lower exotherm than the same mass in a deep pour such as a potting application with less surface area and less thermally conductive surroundings. Care should be taken with fast-curing adhesives to ensure the exotherm remains within acceptable limits for the materials being bonded.

5.4.5

Performance and testing of cured adhesive

The typical cured performance of an adhesive is measured by its resistance to the load and environment of an application. Strength and environmental resistance testing ensures that the adhesive meets design requirements. Henkel recommends that testing be performed for all new adhesive applications under simulated or actual end-use conditions to ensure the adhesive meets or exceeds all required product specifications. Since assembly conditions may be critical to adhesive performance, it is also recommended that testing be performed on specimens assembled under simulated or actual production conditions.

FIGURE 8
Types of loads acting separately or in combination on bonded joints.

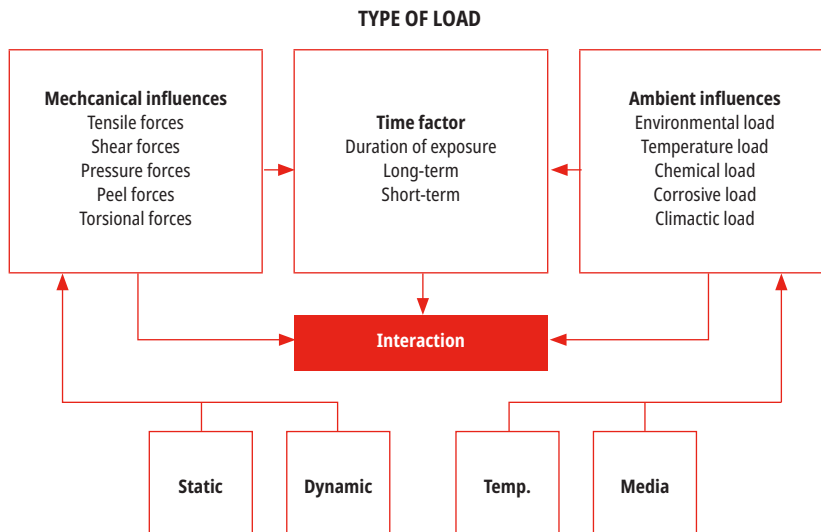

Cured adhesive strength

5.4.5.1

The strength of a bonded joint is determined by its resistance to shear, tension, compression, impact, peel and torsion loads. Many standardized test methods can be used to compare the strength of an adhesive and assist in product selection. It is important to consider the types of loads the joint will see in service to ensure that the appropriate test is used to qualify the adhesive.

Effect of environment on cured bondline

5.4.5.2

Temperature exposure can impact the strength of an adhesive bond joint. Heat aging and hot strength are two types of temperature tests performed to provide an indication of how an adhesive will perform at elevated temperatures.

The hot strength of an adhesive is determined by exposing the bonded joint to an elevated temperature and performing a strength test at the elevated temperature.

Heat aging is conditioning that exposes a bonded joint to an elevated temperature for a given period of time without exposure to stress. It is then brought back to room temperature, 23°C (73°F), and tested to determine the strength at room temperature. Heat aging is best suited to help understand the strength retention in applications when the parts might be subjected to extended periods of elevated temperature but brought back to room temperature prior to being subjected to forces. Custom temperature programs can be designed to simulate and test for real-life heat patterns on assemblies.

Chemical conditioning is conducted in a similar manner to heat aging. A bonded joint is exposed to a chemical or solvent for a given period of time, then removed and tested to determine the effect of this chemical exposure on the bond strength. Chemical conditioning is usually tested at room temperature immediately after removal from the chemical, but the test can also be conducted at an elevated temperature.

While there are many factors that affect the performance of an adhesive over the long term, temperature and chemical exposure are the most significant influences. It is important to simulate the operating environment as closely as possible in order to accurately predict performance. For example, a chemical at room temperature may not affect the performance of an adhesive as significantly as a chemical at an elevated temperature, as the combined conditions may be more severe than the sum of the individual influences.

Section 6

THREADED ASSEMBLIES

How they work. Why they fail.
And how to prevent it.



Threaded fastener mechanics

6.1

Threaded fasteners are primarily employed for their exceptional clamp load and ability to hold objects together, but their removability is also an important characteristic. For manufacturers, removability is often fundamental for maintenance, service or repair, even if only a small percentage of products ever need to be disassembled.



FIGURE 9
Threaded fastener.

Clamp load is exerted by creating tension in the fastener. When someone buys a nut and a bolt, with few exceptions, they are buying one thing: clamp load. Threaded fasteners provide an important certainty—they make it possible to predict how much force is going to be exerted and how long it will stay at that value. In addition, at some point, one may wish to remove the clamp load and disassemble the parts. Nuts and bolts fill this function well, but understanding and addressing the principles behind threaded fasteners will help ensure the expected long-term, reliable results.



For more content on **Clamp Load**, see **chapter 1** of the Threadlocker LOCTITE[®]XPLORE e-learning course.

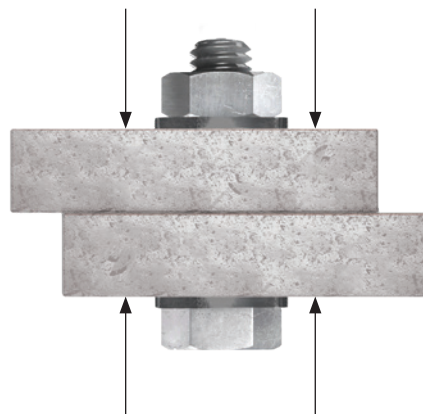
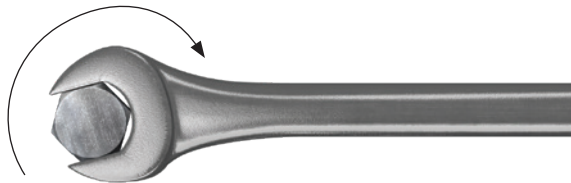

FIGURE 10
Clamp load is exerted by tension in the fastener.

To generate tension in the fastener and consequently clamp load, rotational force, known as torque, is applied. Torque is defined as a force about an axis of rotation. As a threaded assembly is tightened, torque causes it to twist or rotate. A clockwise torque to a right-hand threaded part causes one thread to climb the other, and any bearing surface (such as a clamping flange) between the male and female threaded fasteners provides resistance to the continued climbing of threads. Further torquing causes the fastener to elongate or stretch between the bearing surfaces until there is balance between the torque applied and the reaction force due to the sum of the fastener tension and friction.

FIGURE 11
Torque is the twisting or rotary force in a mechanism.



The relationship between these two forces is called the torque-tension relationship. Broadly speaking, for a given torque load applied to a fastener, a specific tension or clamp load will be generated by the fastener, dependent on friction and the fastener's diameter. **The equilibrium relationship is often expressed mathematically:**

EQUATION 1
Torque-tension - short form.

$$T = K D F$$



- T = Torque, N.m (in-lb)
- D = Nominal diameter of bolt, m (in)
- F = Induced force or clamp load, N (lbf)
- K = k-factor (unitless)

Play with the **K Factor Formula** in **chapter 7** of **LOCTITE[®]XPLORÉ** Threadlocking course.

The k-factor is an empirical constant that is dependent upon many influences, including friction, fastener size and material and assembly parameters. It has many names, including 'nut coefficient', 'torque coefficient', 'nut factor' and 'K value'. For consistency, this text will use the term 'k-factor' throughout.

Inclined plane

The inclined plane is the core concept of a threaded fastener that makes it so useful. If we were to roll a threaded fastener across a flat surface and at the same time 'unwrap' the thread, we would be left with something similar to the diagram shown in Figure 12. What was once a helical thread has now become an inclined plane. The angle of this inclined plane is controlled by the thread pitch.

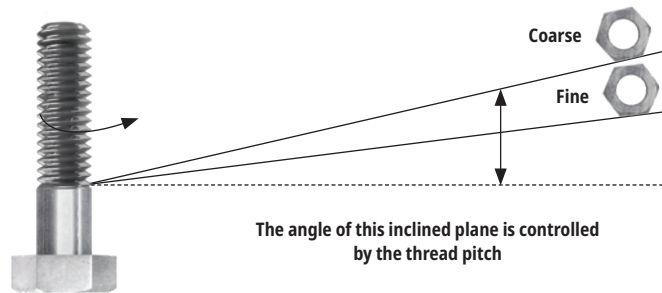

FIGURE 12
Correlation of thread pitch and inclined plane.

Typically, an M10 x 1.5 mm bolt would produce an inclined plane of approximately 3.0 degrees, and the approximate US equivalent 3/8" x 16 would produce an inclined plane of approximately 3.4 degrees.

When threaded assemblies reach the bearing surfaces, torque is transferred along the long axis of the bolt, causing it to stretch much like a spring. The more torque that is applied, the more the bolt elongates and, in turn, the greater the applied clamp load. If the direction of rotation is reversed, the clamp load is reduced, and the bolt returns to its original length.

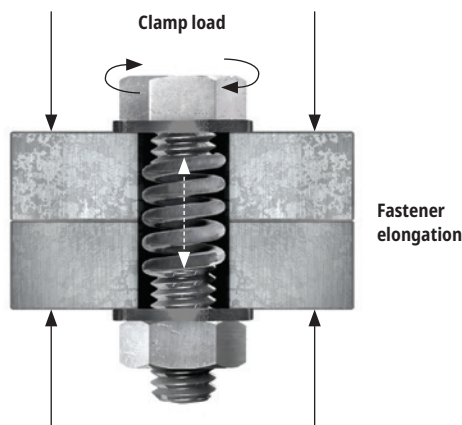
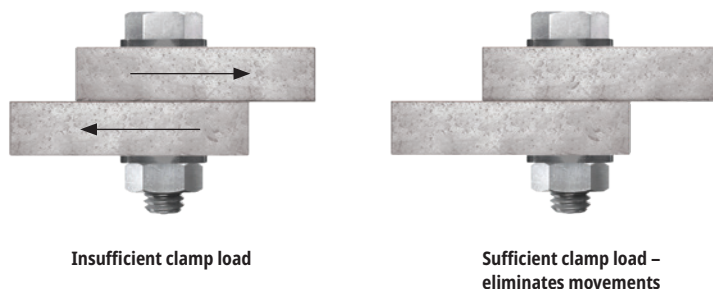

FIGURE 13
Torque applied is stretching the fastener similar to a spring and resulting in clamp load.

The clamp load is used to hold separate objects together and prevent them from moving independently of one another. The force that prevents this movement is friction.

FIGURE 14
 Clamp load holds separate objects together to prevent relative movement of the objects.



When external forces exceed the surface friction between the two clamped faces, movement occurs. This causes the fastener to fail because of the core design principle of threaded fasteners, the inclined plane.

FIGURE 15
 Free-body diagram during tightening.

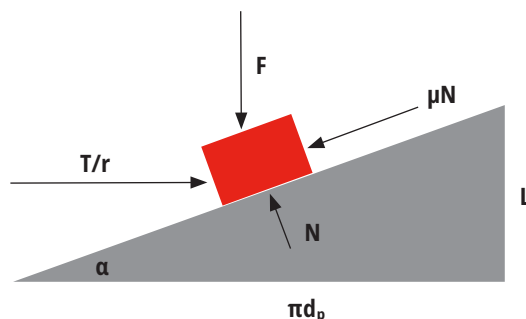

In Figure 15, the triangle represents one 360-degree segment of a bolt that has been figuratively unwrapped. The block represents an element of the nut bearing against the inclined plane formed by the unwrapped and flattened thread (the thread engagement between a nut and bolt). When the torque (T/r) applied to the nut is greater than the friction force (μN), the nut will climb the inclined plane, tightening the fastener. The friction force is proportional to bolt tension (F). Friction is low until bolt stretching starts to occur and the bolt tension increases. As friction increases with tightening, eventually, equilibrium will be achieved, and the nut will stop.

When the torque load is removed, the bolt tension will push in the direction that would cause the nut to move back down the incline plane, while the friction will resist in the opposite direction, preventing slipping (Figure 16).

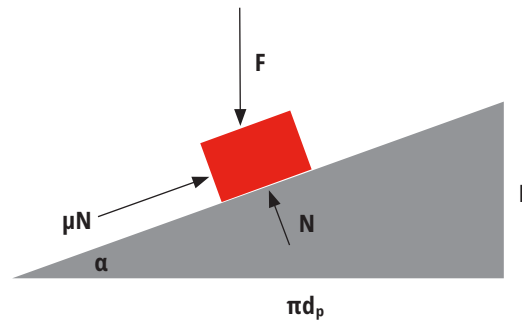

FIGURE 16
Free-body diagram
of static threaded
assembly.

If the mating surfaces of the threads are highly polished and smooth, there is less friction. This makes it more likely that bolt tension will cause the nut to move back down, loosening the assembly until equilibrium is achieved again.

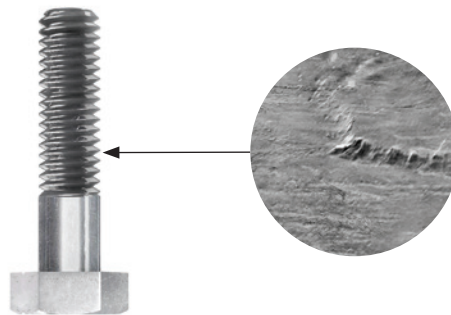

FIGURE 17
Thread surface finish.

The thread finish shown in Figure 17 represents a close-up view of a thread on a typical fastener. Notice the roughness of what would appear to the naked eye as a smooth thread. The roughness of this finish increases the friction between the threads of the fastener and the nut, which, in turn, prevents the fastener from the tendency to 'unwind' due to the stress of the tensile loading.



Getting the right clamp load

One consideration when choosing the right bolt is the expected service loads and how they fluctuate. When the clamp load is greater than the external loads on the joint, the bolts do not experience cyclic loads and therefore bolt fatigue is minimized.

For a required clamp load 'F', the engineer must choose the appropriate fastener. The relationship between clamp load and the stress in the bolt 'S' is expressed by the following equation:

EQUATION 2
Stress in the bolt.

$$S = F / A$$

Where 'A' is the tensile cross-sectional area of the bolt or, more usually, the sum of the areas of several bolts used to provide the clamp load. The size and number of bolts can then be determined from the torque tension equation:

$$T = K D F$$



In LOCTITE[®]EXPLORE **chapter 1**, you'll learn if your **nut or bolt is tightened just right.**

The target clamp load and equivalent target tensile load for each fastener should be considered within the bolt manufacturer's guidelines. This value is based on the tensile strength of the fastener classes (metric) and grades (imperial) and their tensile cross-sectional area. Manufacturers who wish their fasteners to be classified will certify that their materials meet the grade or class.

Hooke's law allows us to determine how the elongation of a fastener results in clamp load. Under most applications, target loads are kept within the elastic range of the fastener. Torque charts published by bolt manufacturers most often indicate a 75% proof load as the targeted value. This target ensures that the bolt is not stretched past its yield point. Going past the yield point causes permanent bolt elongation (yielding, or plastic deformation) of the fastener. If the bolt material is a precondition, the optimum value of 'S' is known and therefore 'A' can be calculated.

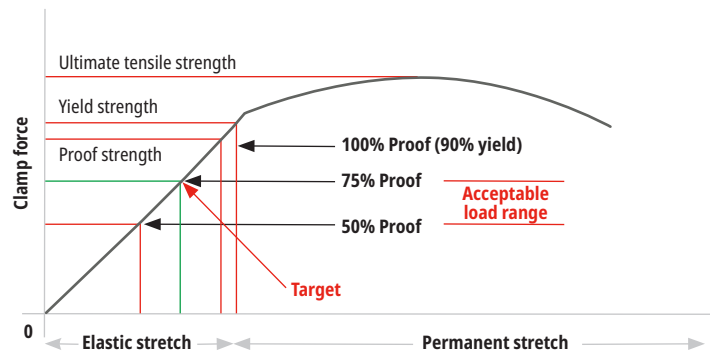

FIGURE 18
Clamp force vs.
elongation.

Controlling clamp load

6.3

There are several accepted methods for measuring clamp load. Three of the more common methods are:

1. Measuring the elongation or stretch of the fastener as it is tightened.
2. Measuring the clamp load directly.
3. Measuring the torque applied to the fastener.

Method 1

Measure bolt elongation

This method of measuring tension is extremely accurate, with accuracy generally within $\pm 5\%$. All threaded fasteners stretch under the influence of tensile loading. The extent of elongation per unit of increase in load is proportional for fasteners within their elastic limit and is determined by:

- A. The tensile strength of the material from which the fastener is made.
- B. The diameter of the fastener.
- C. The working length of the fastener.
- D. The fastener application.

For example, assume an M10 high-tensile steel fastener with a 25 mm (~1") working length elongates 0.05 mm (~0.002") for every 13350 N (~3,000 lbf) of tensile load. Achieving a clamp load of 26,700 N (~6,000 lbf) requires a fastener to be tightened to the point where its overall length is increased by exactly 0.10 mm (~0.004"). This method requires precisely flat surfaces on the ends of the bolt. The most common industrial fasteners are not flat at the end of the thread and will have markings on the bolt head to identify its strength. Accurate measurements would require machining these surfaces flat. Due to the added time and cost, this method is therefore unsuitable for most assembly or maintenance operations but is used in some industries and applications where extremely tight tolerances must be maintained.

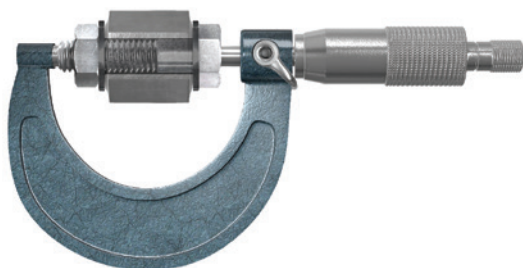

FIGURE 19
Measuring fastener elongation.

A variation of this method is the practice of measuring the 'turn of the nut'. Using a fastener with a 1.0 mm (0.04 in) pitch as a reference, we know that each 360-degree turn of the nut advances it 2.0 mm (0.08 in) along the axis of the bolt. Assume that each 1.0 mm (0.04 in) elongation of the fastener generates a stress of 146.8 kN (33,000 lbf).

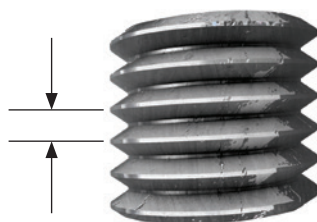

FIGURE 20
'Turn of the nut'.

To load this fastener to 24.5 kN (5,500 lbf), first advance the nut along the thread until it is in firm contact with the bearing surface, then tighten it a further 1/6 of a turn (60 degrees). This will elongate the fastener and give a clamp load of 24.5 kN (5,500 lbf). This is possibly the oldest known method of measuring fastener tension.

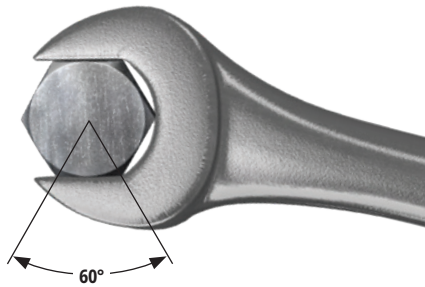

FIGURE 21
1/6 of a turn = 60°.



Method 2 Direct measurement

Clamp load can be measured electronically by means of a strain gauge, load cell or other type of force transducer placed under the nut or head of the bolt. This is often a very expensive method that usually requires that the measuring device be left in place after assembly. This method is limited to ultra-critical assemblies such as turbines and some high-speed machinery. This is considered to be the most accurate method, with a range of accuracy between 1 and 2%. A variation of this method involves load-indicating washers such as those used in aircraft. These washers are designed so that when they are subjected to load, they gradually deform to a position that indicates the load value.

Test the right bolt tension load in LOCTITE[®]XPLORE Threadlocking course, **chapter 1**.

Method 3 Measure torque

This is the simplest and most widely implemented method used in engineering. It is also the least accurate. The variables involved in using this method can result in errors of $\pm 25\%$. The margin of error can be magnified by coefficients of friction, lubricants, burrs on bearing surfaces, flexibility of the structure and operator error. Therefore, when torque is used to control clamp load, testing is recommended to determine either the coefficients of bearing and thread friction or the k-factor of the assembly configuration.

6.3.1

Determining the k-factor

The k-factor is the most simple way to describe the friction of a threaded assembly. The k-factor can be determined using a clamp load transducer along with a torque-measuring device. When a fastener is loaded and tightened into a clamp load transducer, it clamps onto a piston that generates hydraulic pressure internally. This pressure is indicated on a pressure gauge but is calibrated to the piston surface area to indicate clamp load.

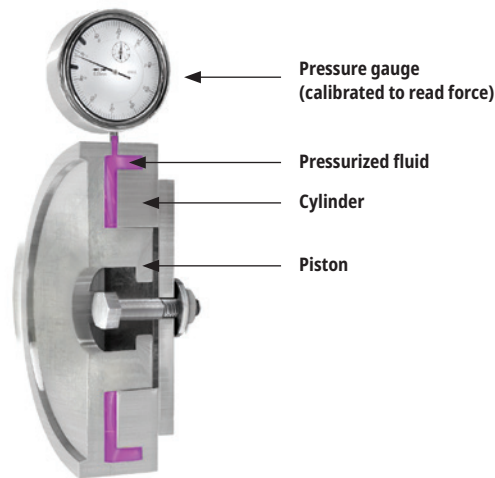

FIGURE 22
Clamp load transducer.



LOCTITE[®]XPLORER
Threadlocking course,
chapter 7 explains
the equations. Check
it out after reading this
section.

It should be noted that the k-factor does not describe a particular thread lubricant such as a grease, oil, anti-seize or threadlocker. It describes the friction of the specific assembly tested. When performing k-factor determination tests of a simulated threaded assembly, care must be taken to properly replicate the configuration of the bolted joint so that both thread friction and bearing friction are properly simulated. Over many test replicates using the specified hardware and torque tools, a realistic assessment of the expected variances in tension can be determined.

6.3.2

Mathematics of bolt tightening

As previously shown in Figure 16, to perform an analysis of a bolt, one 360-degree segment of a bolt is figuratively unwrapped. The fact that the face is tipped 30-degrees from the plane to the bolt axis is ignored. A diagram can then be drawn, as in Figure 23, where the forces are broken down into their vector components. The block represents an element of the nut bearing against the inclined plane formed by the unwrapped and flattened thread. Since the system is in equilibrium, all forces will balance one another. In other words, all the forces acting parallel to the ramp will sum up to zero, and the sum of all forces acting normal to the ramp will equal zero.

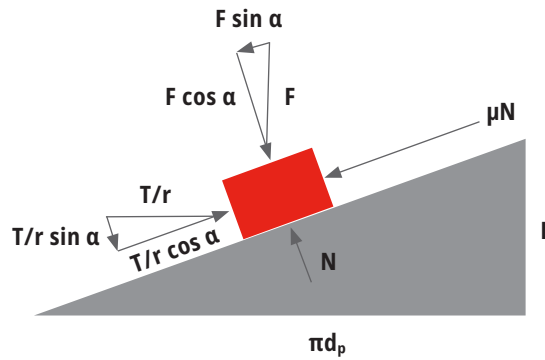

FIGURE 23
Free-body diagram of
nut and screw thread.

F = Force applied by the bolt
T = Torque applied to bolt
N = Normal force on friction surface
μ = Coefficient of friction = 0.15
dp = Diametrical pitch
α = Helix angle whose tangent = $L/(\pi dp)$
L = Lead of thread

$$\textcircled{1} \quad \sum F_{\parallel} = 0$$

$$\left[\frac{T}{r} \cos \alpha \right] - \mu N - F \sin \alpha = 0$$

$$\sum F_{\perp} = 0$$

$$N - F \cos \alpha - \left[\frac{T}{r} \sin \alpha \right] = 0$$

$$\textcircled{2} \quad N = F \cos \alpha + \left[\frac{T}{r} \sin \alpha \right] \text{ [a small value that can be dropped]}$$

$$\textcircled{2} \text{ into } \textcircled{1} \quad \left[\frac{T}{r} \cos \alpha \right] - F \cos \alpha - F \sin \alpha = 0$$

$$\textcircled{3} \text{ in lb-ft. } \rightarrow T = r \left(\frac{\mu F \cos \alpha}{\cos \alpha} + \frac{F \sin \alpha}{\cos \alpha} \right)$$

$$\rightarrow T = rF(\mu + \tan \alpha)$$

$$\rightarrow T = \frac{d_p}{24} F(\mu + \tan \alpha)$$

Using this formula, let's calculate the torque required to achieve the same 5000 lbf (22.2 kN) clamp force on a 3/8" coarse thread and a 3/8" fine thread (approximate metric equivalent M10 x 1.5 mm and M10 x 1.25 mm).

TABLE 6
Fastener parameters.

3/8" X 16 UNC ¹ (COARSE)	3/8" X 24 UNF ² (FINE)
F = 5000 lbf. (given)	F = 5000 lbf. (given)
α = 3.5° u = 0.15	α = 2.2° u = 0.15
d _p = 0.330"	d _p = 0.344"
N = 750 lbf.	N = 750 lbf.

¹ UNC - Unified national coarse

² UNF - Unified national fine

3/8" UNC:

$$\rightarrow T = \frac{d_p}{24} F (\mu + \tan \alpha) = \frac{0.33}{24} (5000)(0.15 + \tan(3.5^\circ)) = 14.5 \text{ lb-ft}$$

3/8" UNF:

$$\rightarrow T = \frac{d_p}{24} F (\mu + \tan \alpha) = \frac{0.344}{24} (5000)(0.15 + \tan(2.2^\circ)) = 13.5 \text{ lb-ft}$$

Therefore, fine threaded fasteners require less torque to achieve the same clamp load.

By assuming that the screw thread was 100% efficient and there was no friction, you can calculate how much torque is needed to induce the clamp load.

3/8" UNC:

$$T = \frac{d_p}{24} F (\mu + \tan \alpha) = \frac{0.33}{24} (5000)(0 + \tan(3.5^\circ)) = 4.19 \text{ lb-ft}$$

3/8" UNF:

$$T = \frac{d_p}{24} F (\mu + \tan \alpha) = \frac{0.344}{24} (5000)(0 + \tan(2.2^\circ)) = 2.7 \text{ lb-ft}$$

Let's now consider the effects of friction under the head of the bolt.

Again, with a 5000 lbf clamp load and assuming an effective bearing diameter of the nut of 0.400 in, the torque required to overcome the bearing friction is:

T = moment arm × force

D_e = effective diameter of bearing surfaces (3/8" nut = 0.40")

$$\frac{T}{r} = \mu F$$

$$T = r\mu F = \frac{d_e \mu F}{24} = \frac{(0.4)(0.15)(5000)}{24} = 12.5 \text{ lb-ft}$$

TIGHTENING TORQUE	3/8" X 16 UNC ¹ (COARSE)		3/8" X 24 UNF ² (FINE)	
To overcome thread friction	10.3 lb-ft. (14.0 N.m)	38%	10.8 lb-ft. (14.6 N.m)	42%
To overcome head friction	12.5 lb-ft. (16.9 N.m)	46%	12.5 lb-ft. (16.9 N.m)	48%
To create bolt tension	4.2 lb-ft. (5.7 N.m)	16%	2.7 lb-ft. (3.7 N.m)	10%
Total	27 lb-ft. (36.6 N.m)	100%	26 lb-ft. (35.3 N.m)	100%

¹ UNC - Unified national coarse

² UNF - Unified national fine

TABLE 7
Absorption of tightening torque.

Loosening torque

In a similar manner, loosening torque can be computed while accounting for the fact that the thread extension component assists the untightening process.

3/8" UNC:

$$T = \frac{d_p}{24} F (\mu + \tan \alpha) \frac{0.33}{24} (5000)(0.15 - \tan(3.5^\circ)) = 6.1 \text{ lb-ft}$$

3/8" UNF:

$$T = \frac{d_p}{24} F (\mu + \tan \alpha) \frac{0.344}{24} (5000)(0.15 - \tan(2.2^\circ)) = 8.0 \text{ lb-ft}$$

For total loosening torque, the bolt head friction component remains the same and must be added.

TABLE 8
Loosening torque.

LOOSENING TORQUE	3/8" X 16 UNC ¹ (COARSE)	3/8" X 24 UNF ² (FINE)
To overcome thread friction	6.1 lb-ft. (8.3 N.m)	8.0 lb-ft. (10.8 N.m)
To overcome head friction	12.5 lb-ft. (16.9 N.m)	12.5 lb-ft. (16.9 N.m)
Total loosening torque	18.6 lb-ft. (25.2 N.m)	20.5 lb-ft. (27.8 N.m)
Loosening torque as % of tightening torque	69%	79%

¹ UNC - Unified national coarse

² UNF - Unified national fine

Therefore, for UNC threads, loosening torque is 70% of the tightening torque, and for UNF threads, loosening torque is 80% of the tightening torque.

Influencing factors in achieving correct clamp load

Since torque control is the simplest and most common method for achieving the correct clamp load, it is important to understand why errors of ± 25% are typical. As was calculated in section 6.3, approximately 85–90% of the effort used to tighten a threaded fastener is spent overcoming the friction generated at these points. Only about 10–15% of the effort is used to generate the clamp load produced by the fastener as stored energy. Therefore, torque specifications are based on a prediction of the friction conditions.

TOTAL ABSORPTION IN A TIGHTENED BOLT (PERCENT OF TIGHTENING TORQUE)		
	UNC ¹	UNF ²
Bolt tension	16%	10%
Thread friction	38%	42%
Head friction	46%	48%
Total tightening	100%	100%
Loosening torque	70%	80%

TABLE 9
Torque absorption in tightening bolt.

¹ UNC - Unified national coarse

² UNF - Unified national fine

The short form of the torque-tension relationship (Equation 1) uses the k-factor to summarize friction for a given configuration. The analysis performed in 6.3.2 made an assumption that the coefficients of thread friction and bearing friction were equal at 0.15. Several long form torque-tension relationships have been derived that break down the geometry further and consider separate and unequal coefficients of friction for the threads and the bearing surfaces. One such example is the long form of Equation 1 from ISO 16047, as shown below:

$$T = F \left[\frac{1}{2} \times \frac{P + 1,154 \times \pi \times \mu_{th} \times d_2}{\pi - 1,154 \times \mu_{th} \times \frac{P}{d_2}} + \mu_b \times \frac{D_o + d_h}{4} \right]$$

EQUATION 3
Long form torque-tension relationship

T = Torque
F = Clamp Force
P = Pitch of the thread
 μ^{th} = Coefficient of friction between the threads
 μ_b = Coefficient of friction between bearing surfaces under nut or bolt head
d₂ = Basic pitch diameter of thread
D_o = Outer diameter of bearing surface
d_h = Clearance hole diameter of washer or bearing part

Even though this relationship provides greater detail, the relationship still requires an understanding of the coefficients of thread friction and bearing friction. There are many variables that make these values difficult to predict, including but not limited to:

- Substrate or types of materials
- Surface finish
- Thread tolerances
- Hole clearances
- Use of washers
- Cleanliness
- Lubrication
- How the threads were produced (cut or rolled)
- Speed of assembly
- Length of the engagement (tapped hole vs standard nut)
- Hardness of bearing materials

Fastener variability

It is important to consider variations between fasteners even when they have identical specifications. There are likely to be significant differences between manufacturers, batches and even parts within a batch.

In an experiment conducted by Henkel, it was found that surface finish, along with the variances in under-head bolt design varied greatly between manufacturers. When torqued to the recommended level, fasteners from different manufacturers exhibited significantly different clamp loads.⁵

5. Feeney, *Reliable Threaded Fastener Assemblies*.

Hardware specified as 5/8" x 11 UNC grade 5 zinc-plated steel (approximate metric equivalent is M18 x 2 mm, class 8.8) was sourced from five different manufacturers. This grade of fastener was chosen because it was recommended by bolt suppliers as the most commonly sold to general industry customers. Identical hardened washers from a single manufacturer were used throughout the experiment to control this variable.

The bolts were torqued in 'as-received' condition using a constant torque value, and the clamp load was measured. The result was a 21% deviation in clamp load between manufacturers, or 4100 lbf (18.2 kN) (see Figure 25).



FIGURE 24
Visible variation in fasteners with the same specification from different manufacturers.

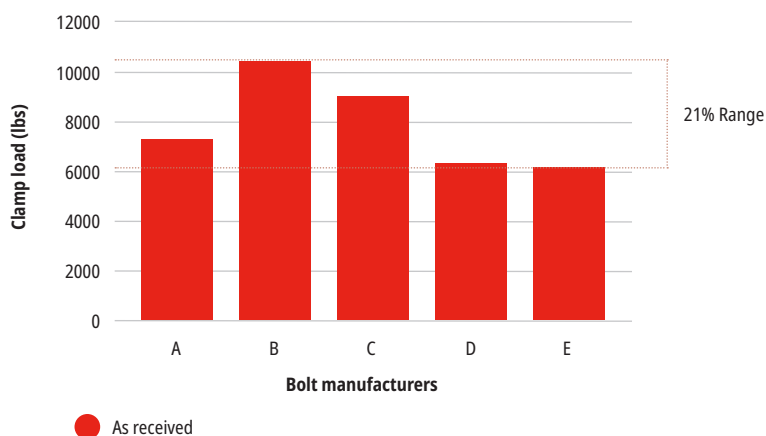

FIGURE 25
Average clamp loads for various bolt manufacturers.

Galling

Galling is wear caused by friction and the buildup of heat between two sliding surfaces. When threaded fasteners are assembled or loosened, heat can be generated very quickly. This effect rapidly changes the friction conditions and may cause the sliding surfaces of the metals to soften and fuse together. A high coefficient of friction between threads and low thermal conductivity in the metals increase the probability of galling during assembly or disassembly. Table 10 shows the thermal conductivity of common metals used for fasteners. Stainless steel is particularly susceptible to this phenomenon. The threads should either be lubricated or assembly speeds should be reduced to avoid galling.

TABLE 10
Thermal conductivity of metals.

THERMAL CONDUCTIVITY OF METALS		
METAL	BTU/HR•FT•°F (IMPERIAL)	WATT/CM•°C (SI)
Copper	231	4
Aluminium	136	2.35
Brass	69	1.19
Zinc	67	1.16
Steel	32	0.55
Stainless steel*	8	0.14

* Stainless steel is most likely to gall

Lubrication

Lubrication of a threaded assembly will provide more predictable friction and therefore more predictable clamp load. Figure 26 shows a plot of the bolt tension achieved for a given tightening torque on a grade 5 black oxide steel bolt (Class 8.8 is approximate equivalent). A molybdenum disulfide-based anti-seize provided the highest levels of lubrication, while a solvent-cleaned assembly had the highest level of friction. The use of a lubricant does not eliminate all other variables of friction, nor does it eliminate torque-tension scatter, but it does help to reduce scatter. Therefore, the presence of a lubricant and the underlying friction conditions still need to be known and should be tested for a given configuration.

It should also be noted that lubrication of an assembly and the reduction of input torque also reduces the bearing friction and thread friction that hold a threaded assembly together, thus making self-loosening more probable. This topic is discussed in greater detail in section 6.4.2.

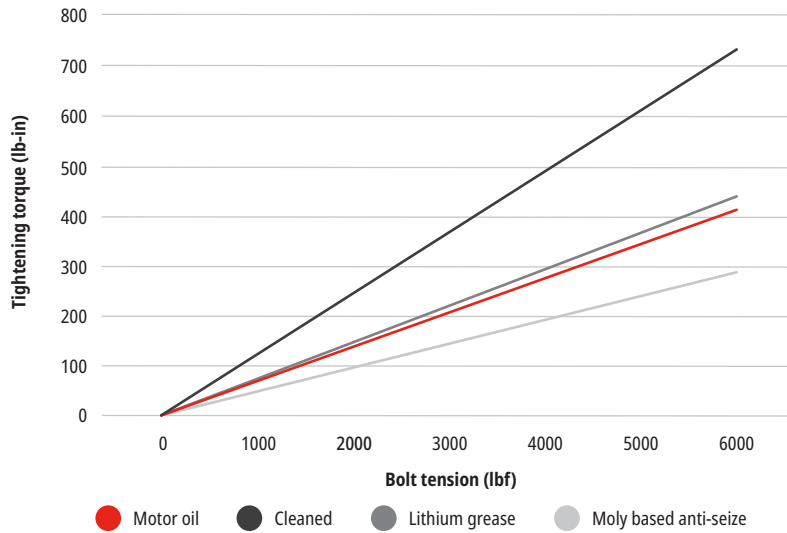

FIGURE 26
Torque-tension plot 3/8" UNC grade 5 - black oxide.

Washers

Washers play an important part in maintaining torque-tension relationships. They are most useful as a means of providing a solid bearing surface for fasteners to work against. By using a hardened washer in conjunction with a threaded fastener, the accuracy of the torque-tension relationship is improved for the following reasons:

- A. The washer generally provides a smooth surface for the bearing surface of the fastener to act against, resulting in lower frictional losses in this area.
- B. The washer spreads the fastener load over a greater surface area.

This is particularly important when clamping soft materials such as alloys. The hard material of the fastener tends to 'settle' into the softer alloy over a period, causing loss of clamp load. Softer materials are more likely to 'yield' or plastically deform. Spreading the load over a larger area helps reduce the probability of this occurring.

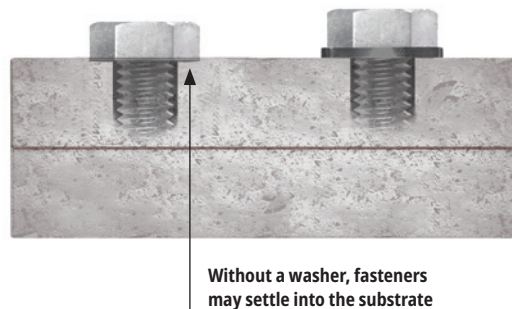

FIGURE 27
Embedment of fastener in bolted substrates.

6.4

Fastener failures

6.4.1

Common myths about threaded fasteners



For 15 mins of fun, **debunk other common myths** in LOCTITE[®]XPLORE **Threadlocking course, chapter 5.**

Among design engineers, technicians, reliability experts and mechanics, these are some of the many common myths about threaded fasteners:

'A bolt that is properly torqued to standard tightening guidelines will never loosen under any circumstances'. In fact, external forces may overcome the static friction of the assembly and cause transverse sliding, which may lead to a loss of clamp load in as few as 100 cycles.

'Fasteners require more torque to loosen than to tighten'. As was calculated in 6.3.2, loosening takes 70–80% of the tightening torque; it is easier to go 'downhill' than it is to go uphill.

'I know it is tightened properly because I torqued it myself'. The specified torque may be reached, but friction may prevent the target clamp load from being achieved. Torque specifications rely on an assumption of friction, which accounts for 85–90% of the input.

This section about fastener failures looks at the reasons threaded assemblies fail and helps further invalidate some of these myths.

6.4.2

Why threaded assemblies fail

With the amount of friction generated between the mating threads of fasteners, it is hard to imagine that they would lose their clamp load. Unfortunately, they do, and often at a great cost. Fasteners fall out of machinery, causing expensive downtime and repair bills as well as possible injuries.

The loss of clamp load in fasteners occurs for many reasons. Some of the most common reasons are:

1. Failure to correctly tension the fastener during assembly
2. Excessive tension in the fastener or over-tightening and stripping threads
3. Relative movement between clamped surfaces (the most common reason for loss of clamp load)
4. Relaxation
5. Fatigue effects
6. Corrosion of the assembly

Failure to correctly tension the fastener during assembly

For optimum performance, fasteners must be installed at the correct tension. A torque wrench or other suitable device may be used to achieve the specified torque, but this is only part of ensuring accurate bolt tension is achieved. The torque specification may have been created using different assemblies, resulting in different thread friction from the nut and bolt and different bearing friction from the nut or underside of the bolt head against the part or washer. The torque specification itself may have been developed with a single fastener size and its K value used to extrapolate for other sizes. On critical assemblies, more accurate means (such as 'turn of the nut' or the fastener elongation method) are specified. However, even when these measures are taken, loss of clamp load and failure are still a possibility.

There is a limit to the tensile loading of any fastener. This is known as the elastic limit. As noted earlier, a fastener begins to stretch when subjected to tensile loading and contracts when the load is released. If a fastener is stretched beyond its elastic limit, it loses its elastic properties and is unable to return to its original length. Consequently, it can no longer provide the intended clamp load. The elastic limit of a fastener lies very close to the yield limit. Common causes for fastener breakage during assembly include incorrectly set clutches on power drivers, the use of torque multipliers on wrenches, uncalibrated torque wrenches or lack of operator training.

The maximum load a fastener can sustain without suffering permanent deformation is referred to as its proof load. For general application in the field, where dynamic loading is common and disassembly is often required, fasteners are generally not stressed above 75% of their proof load capabilities. Limiting the load on fasteners accommodates impact and sudden shocks that occur at frequent intervals and prevents failure under these conditions.

Relative movement between the clamped surfaces

Relative movement between the clamped surfaces is the most common reason for loss of clamp load and fastener tension. There are many causes for such movement. Mechanical stress imposed on a structure, such as shock, impact load or bending, may overcome the friction generated between the clamped surfaces. Functional loads, such as internal pressure, side-loaded pivots or shock, are often observed as vibration. Relative movement is a problem that has plagued the industry since the first threaded fastener was designed. The reason threaded fasteners are unable to resist the relative movements on their own is directly related to the design principle of all threaded fasteners: the inclined plane.



Looking for adventure?
Help us fix a Quad bike failure and see why it's breaking. Visit [LOCTITE[®]XPLORE](#) Threadlocking course, **chapter 6**.

As mentioned previously, bearing friction and thread friction retain the clamp load. In Figure 28, a cross section of a class II threaded assembly is shown (approximate metric equivalent is a 6g-6H tolerance). Class II and 6g-6H fasteners make up the vast majority of all industrial fasteners on the market. As you can see, there is very little metal-to-metal contact between the engaged threads. A class II assembly only achieves 15% metal-to-metal contact on the thread flanks at this level of magnification. That means that 85% of the area is a non-contact surface and therefore is not being utilized to hold that assembly together.

FIGURE 28
Fastener metal-to-metal contact.

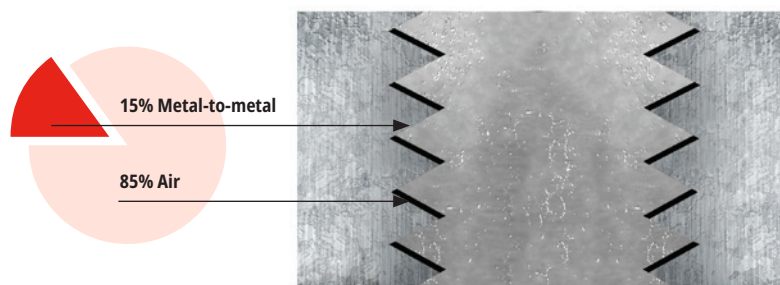

This clearance is by design; it ensures the male and female threads can be assembled relatively easily. However, this is also the reason threaded fasteners are able to self-loosen. For an M10 x 1.5, 6g-6H, there will be from 0.032–0.344 mm in lateral clearance (3/8" x 16, Class 2A/B fastener will have 0.0013–0.0114" clearance), which is the amount that the nut and bolt can move relative to each other. This relative movement is called transverse sliding.

An experiment was performed using a simulated object and inclined plane to see how an object moves when a transverse force is applied to the side of the object. When the object was pushed sideways, it slid down and then stopped. With another sideways push, it slid down and stopped again. Subsequently, when there was a continuous sideways push, the object continued to slide down. This experiment demonstrates that if sideways movement is produced in torqued screw threads, the threads can unwind all by themselves. The higher the clamping forces, the less likely there is to be sideways movement, but if sideways movement occurs, the force will unwind the threads regardless of its magnitude.⁶ In a threaded fastener assembly, this is known as self-loosening.

6. Junker, "New Criteria for Self-Loosening."

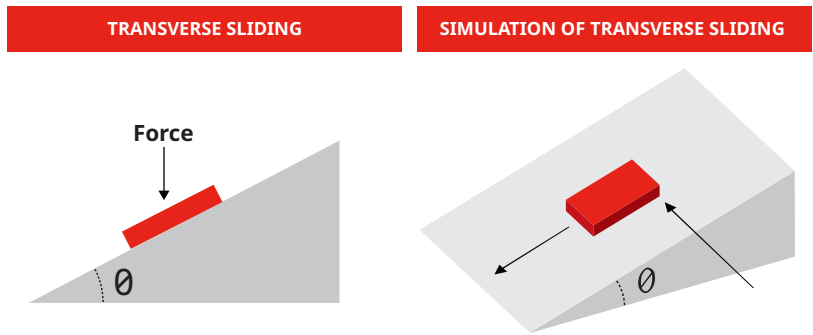

FIGURE 29
Transverse sliding simulation.

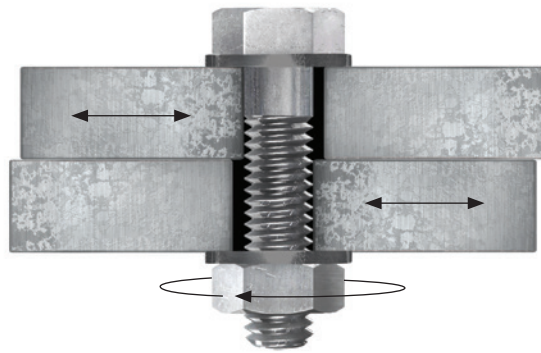

FIGURE 30
Self loosening.

Causes for relative movement

Bending

Suppose that a bolted assembly consisting of two parallel members, clamped together, is subjected to a bending load. As the two members bend and create concentric arcs, a difference in length between the inner and outer member emerges. This puts the inner member in compression and the outer member in tension, which creates shear load between the members, resisted by friction. When that friction is overcome, transverse sliding starts and self-loosening can occur.

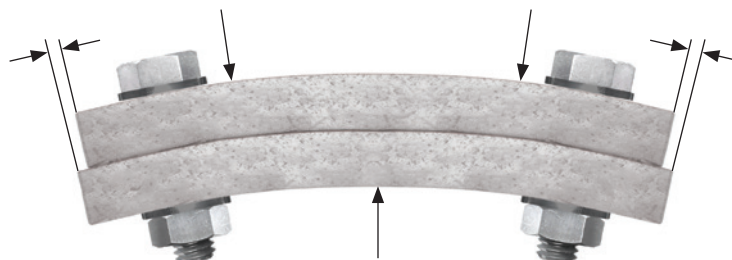
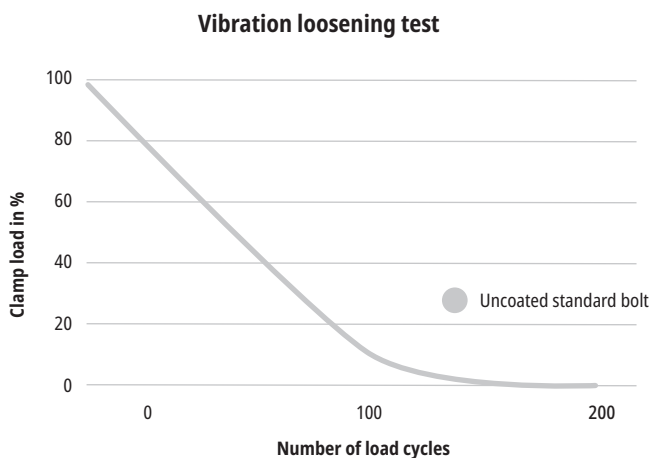

FIGURE 31
Bending of clamped member leads to transverse forces.

Vibrational loosening

Vibrational loosening is one of the most difficult causes of self-loosening to predict because it cannot be determined mathematically. Therefore, the best approach to determine the response to an assembly is experimental testing. Tests done at NASA/Goddard⁷ on structures under high vibrational loads of varying frequency found that vibrational energy had a significant effect on the structures being bolted. If the structure's response to the vibration caused bending or sideways sliding, possibly from inertial forces, the bolts loosened just as they did under slow sliding from single impacts. The frequency of the vibration determined how quickly the loosening occurred.

FIGURE 32
Vibrational loosening test of standard bolt



One structure tested was a simple composite cantilever beam composed of two steel blades bolted together. Slow movements of bending by hand caused loosening of the 1/4" (approximate metric equivalent is M6) bolt after about 100 cycles.

FIGURE 33
Simple composite cantilever beam composed of two steel blades bolted together.



7. Kerley, *An Application of Retrodution*.

Rates of thermal expansion

All materials expand and contract with changes in temperature. However, when two clamped members have different thermal expansion rates, a change in temperature will cause one member to expand more than the other. In the case of the heads of an inline six automobile engine, differing expansion can cause as much as 1.5 mm (~0.060") total change under extreme temperature cycling. When the change in expansion or contraction is restrained, it induces thermal stress. For a properly tightened assembly, friction provided by the clamp load alone resists the stress, but when the thermal stress exceeds friction, relative movement occurs and therefore transverse sliding and self-loosening begin. For every temperature cycle, the transverse sliding will reduce clamp load, possibly losing all clamp load.

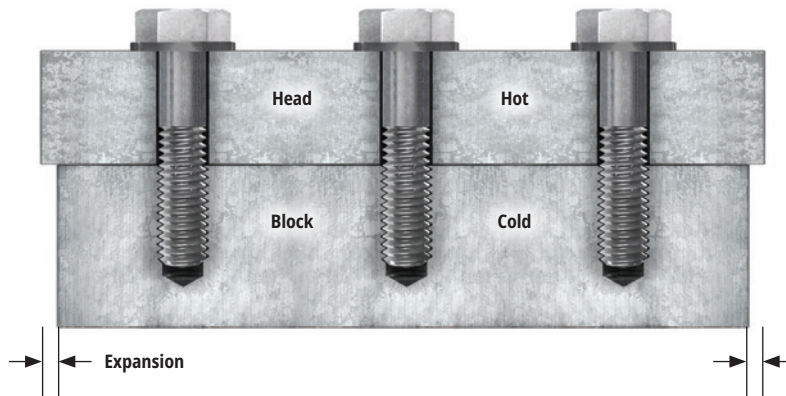
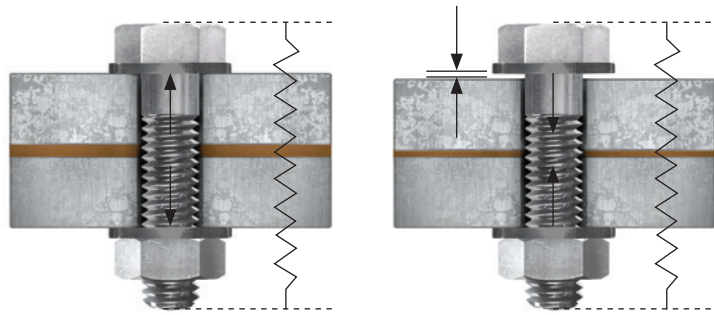

FIGURE 34 Differing thermal expansion (head of inline 6 cylinder engine).

Relaxation

When a fastener is stretched to the target clamp load, it may only be stretching a few thousandths of an inch or a fraction of a millimeter. This means that any small reduction in stretch will result in a loss of clamp load. Materials under compression, particularly the light alloys which are commonly used in machinery manufacture, may deform under the clamp load from threaded fasteners. As the material under the head of the fastener is displaced, loss of clamp load occurs. If the assembly has been painted prior to assembly or includes a gasket, the problem is further compounded. The loss of clamp load allows leakage to occur, as well as independent movement between the clamped forces. This causes further damage to the gasket by abrasion. The movement also helps the fastener to self-loosen. Once the unwinding process has begun, rapid deterioration of the gasketed joint follows.

FIGURE 35
Relaxation of bolted assembly (before and after).



Fatigue effects

The fatigue strength of a bolted joint is evaluated in two ways: fatigue of the bolt, and fatigue of the bolted material. The properly tightened bolt will not fail by fatigue in a rigid joint. Initial bolt tension will stay relatively constant until the external tension load on the joint exceeds the bolt load.

In an experiment by Fastenal™,⁸ three identical ½"-13 x 6" grade 8 hex cap screw assemblies were torqued to 3 different clamp loads: 12,000 lbf, 9,000 lbf and 6,000 lbf. The recommended clamp load for this fastener is 12,750 lbf. Each assembly was subjected to a 12,000 lbf external load. A load cell was placed under the head of the bolt and another on the frame of a tensile tester. Assembly 'A' represents the ideal condition and the joint has been properly tightened. Assembly 'B' and 'C' simulate a joint that has either not been properly tightened or has experienced loosening over time. The results show that fasteners with higher clamp loads experience less change in fastener load. When these loads were modelled in axial fatigue tests, the results showed that the properly tightened assembly would never experience a fatigue failure.

FIGURE 36
Fatigue failure experiment.

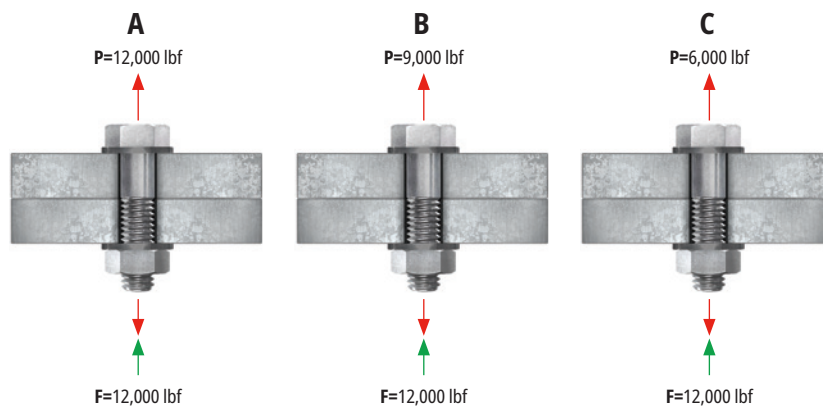

8. Olson, *Preload Influences*, 6, 7.

METAL	A	B	C
Minimum load	12,000	9,000	6,000
Maximum load	12,806	12,322	12,279
Amplitude	806	3,322	6,279
R ratio (min/max)	0.94	0.73	0.49
Cycles to failure	∞	434,266	43,314

TABLE 11
Fatigue failure
experiment results.

If designers do not permit the calculated service load to be greater than the bolt pre-load, the bolt will experience no appreciable stress variation, and without stress variation, there can be no failure by fatigue, regardless of the number of load cycles on the joint.

This is not the case where considerable flexibility is present. Variable stress in screw or bolt fastenings increases with the flexibility of the connected parts. If flexibility is too great, the variable stress present may be high enough to cause eventual fatigue failure of the fastener regardless of the initial bolt pre-load.

Corrosion of the assembly preventing disassembly

Threaded fasteners are employed primarily for their clamp load to hold objects together, but also for their removability. With 85% of the surface area open to air, the joint is open to exposure to salt water, humid air and other corrosive chemicals or environments. These environments will oxidize the metals and can lead to seizure of the assembly. This is an important consideration for maintenance and repairs. The corrosive chemicals and environments described above can act as an electrolyte. When two dissimilar metals are in contact in the presence of an electrolyte, galvanic corrosion occurs. In this situation, one metal becomes the anode and the other metal becomes the cathode. The anode metal will be dissolved into the electrolyte and deposited on the cathode metal. For larger diameter bolts, disassembly may be impossible with the tools available. Once corrosion has occurred, it is quite difficult to disassemble with hand tools, and the fastener may have to be cut with a torch and replaced. As corrosion also reduces bolt strength, the risk of a catastrophic failure increases.



FIGURE 37
Corrosion between
threads.

6.4.3

Traditional mechanical ways to prevent failure

Various methods and devices have been used over the years to reduce or prevent loss of clamp load in threaded fasteners. These solutions mainly assume that the joint is properly tightened to the target clamp load. Any solution for clamp load loss must consider both relaxation and self-loosening.

Bolted joint best practices

The reliability of a bolted joint is increased by implementing the following best practices:

- The surfaces under the bolt head and nut should be smooth and clean. A spot facing operation can be performed if necessary.
- The bolt hole should be chamfered to eliminate burrs and provide clearance for bolt head-to-body fillet. This also reduces the potential stress concentrations and post assembly relaxation.
- A stiff joint and a flexible bolt provide the maximum joint-to-bolt stiffness ratio, minimizing the effects of external loads and temperature change on bolt stress.
- Hard washers should be used to provide a smooth and more predictable surface and distribute contact stresses.
- The bolt and nut should be of identical materials to minimize differential thermal expansion and galvanic corrosion.
- The bolt should extend two full threads past the outer end of the nut when fully tensioned to ensure all nut threads are resisting the tensile load.
- The bolt hole should also be large enough to avoid any interference during assembly but small enough to maximize the bearing surface area and to minimize slip distances.
- The mating joint surfaces should be clean, flat and parallel to each other to reduce stress concentrations, especially bending stresses, and to minimize relaxation due to settling.
- The bolt hole axis should be perpendicular to join-member surfaces to reduce stress concentrations.
- The bolt head and nut should be readily accessible for accurate clamp load control during tightening. The most accurate tightening tools and appropriate procedures should be used.
- For the tightening process, lubricant should be used for the washer and the threads.

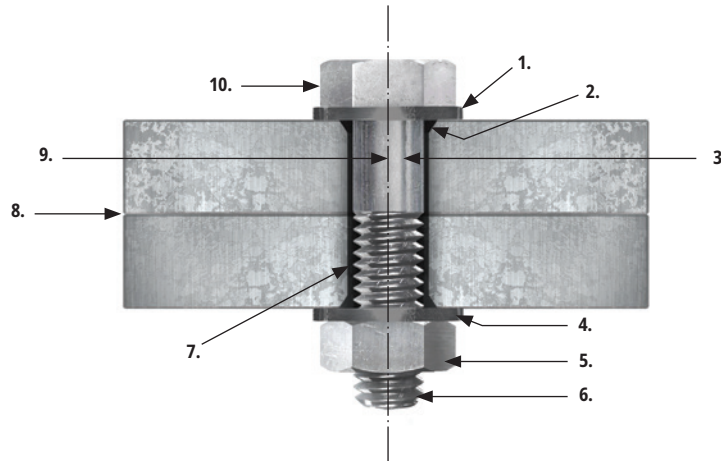

FIGURE 38
Reliable bolted joint (10).

1. **Surfaces** under the bolt head and nut should be smooth and clean. Spot face, if necessary.
2. **Bolt hole** should be chamfered to eliminate burrs and provide clearance for bolt head-to-body fillet. This eliminates potential stress concentrations and post-assembly relaxation.
3. **A stiff joint and flexible bolts** provide the maximum practical joint-to-bolt stiffness ratio, minimizing the effects of external loads and temperature change on bolt stresses.
4. **Hard washers** distribute contact stresses uniformly.
5. **The bolt and nut** are of similar or identical materials to minimize differential thermal expansion and galvanic corrosion.
6. **The bolt** extends two full threads past the outer end of the nut.
7. **The hole** is large enough to avoid cramping or interference during assembly but small enough to minimize slip distances and maximize head, washer and nut-to-joint bearing surfaces.
8. **Joint surfaces** are clean, flat and parallel to each other, reducing stress concentrations—especially bending stress.
9. **The bolt hole axis** is perpendicular to joint-member surfaces to reduce stress concentration.
10. **The bolt head and nut** are readily accessible for accurate preload control during tightening. Use the most accurate tightening tools and procedures that cost permits.

Preventing relaxation

6.4.3.1

If the elasticity of the assembly can be increased to compensate for the expected amount of deformation under load, then the drop in pre-stress force can be significantly reduced. Below are some of the methods and devices used.

Length/diameter ratio

When a fastener is properly tightened, it stretches until the target clamp load is achieved. For two bolts of the same diameter but of different lengths, the longer bolt will elongate more when each is tightened to the same clamp load. Therefore, with an equal reduction in elongation caused by relaxation, the reduction in clamp load is less for the long bolt compared to the short bolt. A high bolt length to bolt diameter ratio is one of the most effective solutions to relaxation when the space is available for a long fastener. However, this may not be practical in some designs. Historically, a length/diameter ratio > 6 has been considered optimum.

Load distribution devices

The use of flange head bolts, flange head nuts and hardened washers reduces the surface pressure that the fastener applies to the bearing surface and thus reduces settling. As noted in section 6.3.3, hardened washers are important for providing a smooth surface for the bearing surface of the fastener to act against, resulting in lower frictional losses. For clarity: this should be considered when eliminating a hardened washer in favour of a flange head bolt or nut. The coefficient of bearing friction may become less predictable when the bearing surface is the clamped part.

Spring washers

Split ring washers, Belleville™ washers, toothed and fan-type washers, bolts and nuts with pressed-on spring head washers or concave bearing washers are all types of spring washers. However, the clamp load they create is only equal to the clamp load needed to compress them, which is significantly less than the target clamp load of a typical structural assembly. These washers are unsuitable for securing bolts of property class 8.8 (grade 5 is the US equivalent) or higher. Under constant compression, over time these devices may relax, losing their ability to create clamp load. Additionally, they cannot prevent self-loosening of the threaded assembly if relative movements exist between the stressed parts.

FIGURE 39
Spring washer and
serrated tooth washer.

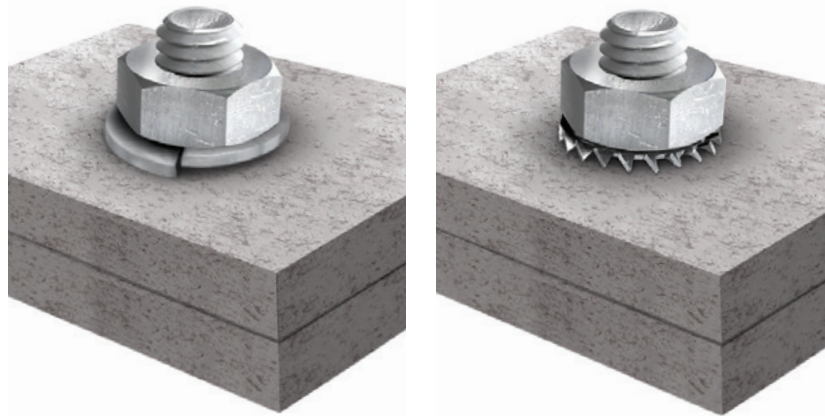

6.4.3.2

Preventing self-loosening

Experts agree that a threaded fastener will not loosen unless the friction forces existing between male and female threads are either reduced or eliminated by some external mechanism acting on the bolt and joint.⁹ Several solutions to the self-loosening problem have been implemented with varied success.

Use of high tensile strength bolts

The friction in a threaded assembly that prevents slipping is directly proportional to the tensile stress of the fastener or the clamp load it is exerting. The use of high-tensile strength bolts may allow clamp loads that are high enough to prevent relative movement. However, higher clamp loads may also worsen relaxation.

9. Brickford, *Introduction to the Design*.

Locking devices

Many locking devices have been engineered to prevent self-loosening over the years. They can be categorized into 4 types:

- Positive locking
- Free-spinning
- Prevailing torque
- Adhesive threadlocking

Positive locking

The earliest attempts involved using lock wires or split pins in conjunction with castellated nuts, along with bolts that had holes drilled for them to accept these locking devices. These are effective measures for preventing loss of fasteners; however, they do not prevent the loss of clamp load. In addition, there are other disadvantages that should be considered. Fasteners must be the correct length for the application. Often, lining up the hole in the bolt with a castellation of the nut requires either backing off the nut or over-tightening it. Consider the difficulty and loss of time to an industry that assembles many components each day, perhaps using thousands of threaded fasteners.



FIGURE 40
Castellated nut with split pin.

Lock wires are commonly used in applications where a dislodged fastener, if broken, may become caught up in other parts of a machine. In instances such as a broken fastener lost in an aircraft engine, the failure could be catastrophic.



FIGURE 41
Locking wires.

These types of locking devices cannot prevent the initial loosening of fasteners, which is the primary cause of most equipment failures. As fastener manufacturing skills and processes have improved, more complex methods of locking have been developed.

Free-spinning types

The free spinner device can be a nut, a bolt or a washer and can freely run down with minimal torque. This form of locking device creates interference with the bearing surfaces during final tightening and must be loaded to work effectively.

The captive-washer types (which can be internal or external) rely upon the sharp edges of the washer digging into the softer bearing surfaces of the fastener and the clamped object. The serrated-tooth variety, both nut and bolt, work in a similar fashion. However, as the serrations are part of the fastener, they need only dig into the bearing surface of the clamped object.

There are several disadvantages to these types of devices:

- A. When serrated teeth dig into the bearing surface, more torque is lost to friction. Higher assembly torque is needed to compensate for this loss.
- B. If for any reason the locking element is disengaged from the bearing surface or fastener tensile load decreases, the locking action ceases to function.
- C. Over a period, the serrations tend to settle into the bearing surfaces, and the clamp load decreases or is lost.
- D. The aggressive serrations tend to gouge out the bearing surfaces, particularly on softer alloys, resulting in the need to repair or replace otherwise sound components.

Of the free-spinning types, the serrated-tooth variety, both nut and bolt, are considered more effective.



FIGURE 42
Serrated tooth bolt and nut.

Wedge locking washers

Wedge locking washers are a type of free-spinning device, but their function is more unique and their design is more complex. A pair of wedge-locking washers with radial teeth on opposite surfaces grip the surface under the bolt head. The inclined plane of the mated locking wedges is at a greater pitch than the screw thread. To loosen the fastener, the pair of washers must be rotated with their angled teeth sliding 'uphill' over each other, briefly increasing the tension on the bolt until the peaks pass each other and release this tension. Therefore, tension must increase before loosening can occur. As with other free-spinning devices, the device must be loaded to allow the radial teeth to grip the surface and prevent each washer from rotating relative to the bearing surface of the part and the nut/bolt head. The grip they provide is limited with hardened surfaces, and the radial teeth may damage the bearing surfaces. These devices do not seal the joint and require more torque to obtain the target clamp load. They are effective, but they're also the most expensive locking mechanism on the market.

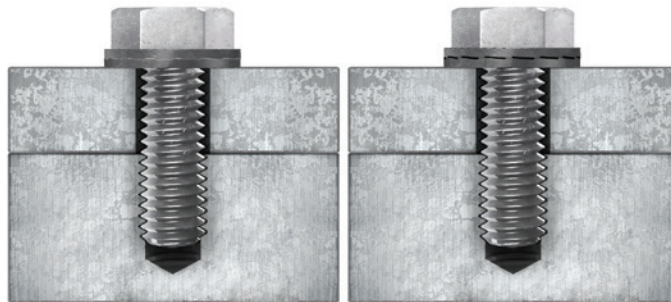

FIGURE 43
Wedge locking washers.

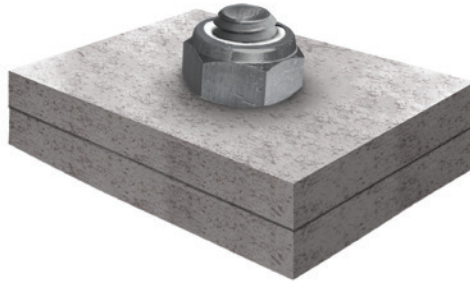

FIGURE 44
Damage done to nut surface from radial teeth.

Prevailing-torque types

Nylon insert nuts do not provide sufficient thread friction to prevent vibrational self-loosening, as was shown in Figure 32. While they do prevent the assembly from vibrating apart due to the prevailing torque provided after loss of clamp load, they are ineffective at maintaining clamp load in high vibration environments and do not seal the threads from corrosion.

FIGURE 45
Nut with nylon insert.



Another locking method involves distorting the thread during manufacture. This is accomplished by indenting certain areas of a nut, or, in the case of set screws and some bolts, by producing a distorted-thread profile.

FIGURE 46
Deformed thread nut.



This, in turn, creates a binding effect between male and female threads. Due to the added friction, prevailing-torque type devices require additional torque during tightening to achieve the target clamp load. They also require torque to thread onto the fastener before they engage the bearing surface. This means they cannot be finger tightened. They may also be prone to corrosion, as they do not seal the threads, and are limited to a single use.

Threadlockers

6.5

Adhesive threadlocking

By applying adhesive that cures between the threads, the degree of freedom for lateral movements is eliminated as the gaps between the threads are completely filled, and at the same time thread friction is increased after the adhesive has cured. These adhesives are known as adhesive threadlockers and will be covered in detail in section 6.5

The LOCTITE® Threadlocker solution

6.5.1

The introduction of adhesive threadlocking products eliminated many of the design faults and shortcomings of threaded fasteners. Threadlockers are anaerobic adhesives, which cure to a tough solid state when deprived of atmospheric oxygen (air). The cured product is a thermoset plastic, which cannot be liquefied by heating and resists most solvents. These products are specifically designed to lock and seal threaded components.

Features, benefits and advantages of threadlockers

Torque resistance

Threadlockers lock more reliably than traditional free-spinning, prevailing-torque or positive lock types because they generate both break-loose and prevailing torque. Break-loose torque is the initial effort required to start rotation of a threaded fastener that has been locked using mechanical or chemical means. Prevailing torque is the effort required to maintain rotation of a threaded fastener after any locking mechanism has been released.

Protection from corrosion and seizure

Traditional locking devices can be used in combination with lubricants and anti-seize compounds to protect against corrosion; however, the reduction in friction caused by these materials may also compromise the function of the assembly. Adhesive threadlockers prevent threaded fastener seizure from corrosion by sealing threads against the entry of moisture.

Controlled strength

The strength of adhesive threadlockers can be controlled by product selection. LOCTITE® Threadlockers are graded by their various strengths into three distinct classifications: Low strength, medium strength and high strength. This versatility allows removability if desired, or a strong bond that is highly resistant to loads, chemicals and temperature extremes.

Reduced inventory

As liquids, adhesive threadlockers fit any size assembly. Stocks of various sizes of mechanical threadlockers are not required, thereby reducing the cost of large inventories.

Thixotropy

Many threadlocker grades are thixotropic by design. This feature minimizes the tendency for liquid product to ‘migrate’ into areas where it is not required or wanted. The thixotropy also improves the gap-filling ability of the product.

Reduced torque tension scatter

Some threadlocker grades have a lubricant incorporated in their chemical composition. This is used to reduce the torque tension ‘scatter’ associated with threaded fasteners. In the fastener variability study discussed in section 6.3.3, which found differences in average clamp load for ‘dry’ assemblies using 5 bolts with identical specifications varied by up to 21%, a lubricating medium-strength threadlocker was also tested. The results showed that the average scatter was reduced to 12%.

FIGURE 47
Effect of fastener variability with threadlocker.

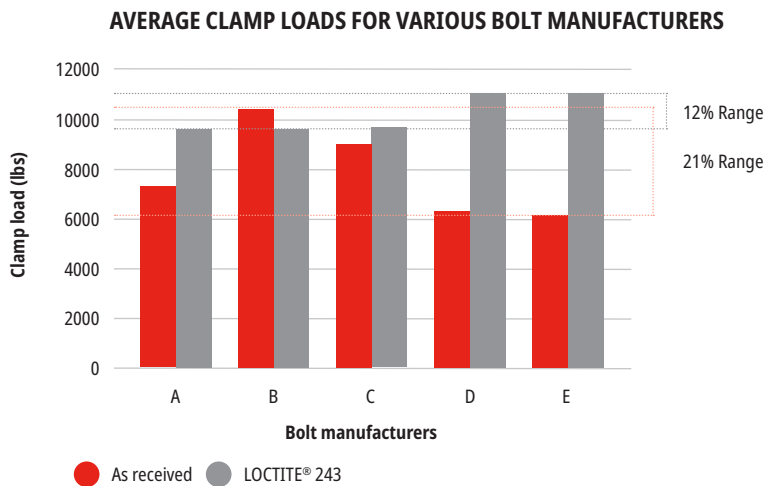

Technical data for lubricants and other thread treating materials will often have the k-factor values listed such as those shown in Figure 48. These values were obtained on 3/8" x 16 (metric approximate M10) nuts and bolts, where the nut was torqued. Both the threads and the nut face were lubricated. Note that the data shown is specific to the configuration. An unlubricated bearing surface, either nut or bolt head, can almost double the K value. The variation in friction and therefore in values for K, is wide, since it is the result of extremely high pressure between surfaces that may be rough, smooth, oxidized, chemically treated and/or lubricated. It should also be noted that typically there is significant scatter within a batch of fasteners from a single manufacturer. Some threadlocker grades provide equal levels of lubrication to oil and greases, and when they are used, the torque tension scatter is narrowed, which provides consistent bolt tension and improves reliability (see Figure 48). Materials like graphite and/or molybdenum disulfide-based lubricants can provide less scatter. Friction absorbs 80-90% of the

tightening torque. Therefore, it is prudent to test a particular assembly configuration in a torque testing device, as described in section 6.3, to determine proper torque values for assuring good control of bolt tension.

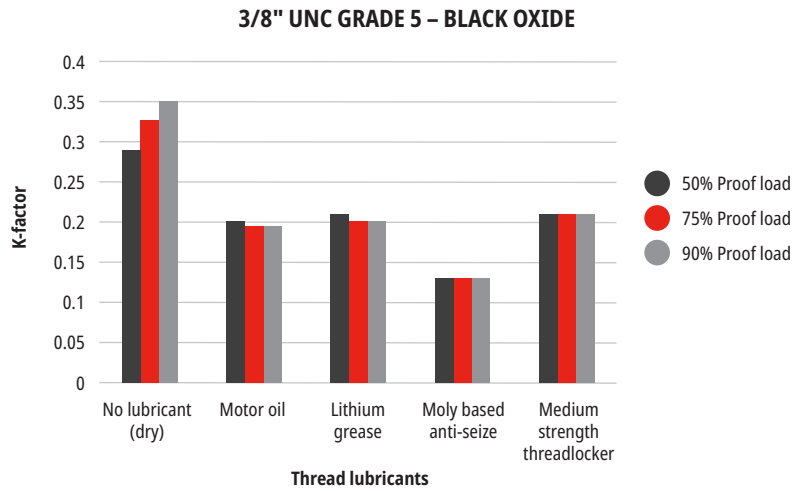

FIGURE 48
Comparison of k-factor in black oxide 3/8" UNC grade 5 bolts.

Locking performance

One of the most well-known and aggressive tests for measuring resistance to

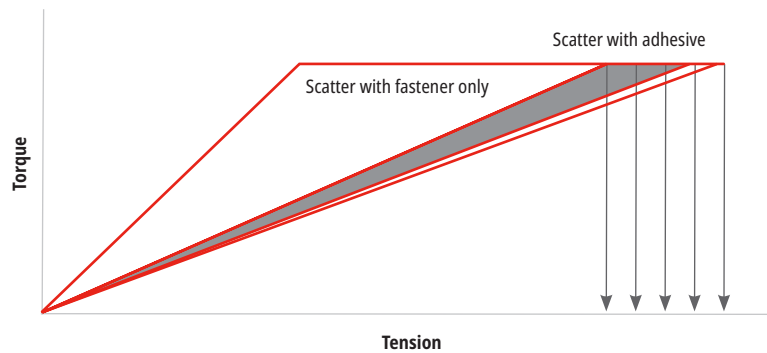

FIGURE 49
Torque-tension scatter: shaded area is with threadlocker, unshaded is without.

self-loosening is the 'Junker Test', also known as the transverse shock test. This test was described in 1969 by German engineer Gerard Junker, who performed extensive research into vibrational loosening.¹⁰ The test machine uses an eccentric cam that generates a controlled amount of transverse displacement to the tightened assembly being tested. A roller bearing between the clamped parts of the assembly allows for free transverse movement, unrestrained by friction. Load

10. Junker, "New Criteria for Self-Loosening."

sensors in the equipment directly measure the clamp load and can generate a curve showing the loss or retention of various devices. The results provide relevant data for comparing the performance of locking devices in regards to self loosening, but is not used to simulate total design.

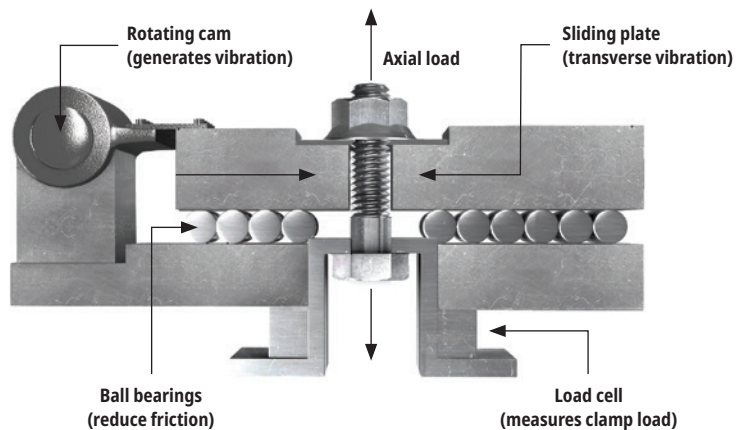

FIGURE 50
Junkers 'transverse shock machine'.

As can be seen in Figure 51, LOCTITE® Threadlocker has the best clamp load retention performance among those tested. Most traditional locking devices fail this test, resulting in loss of clamp load.

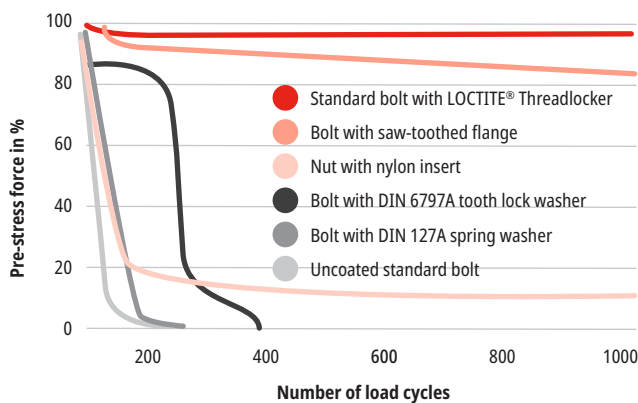

FIGURE 51
Clamp load retention tests - transverse shock machine.

Improved fatigue resistance

Test results indicate that rigid members bolted together by relatively elastic bolts offer the best method to prevent fatigue failure. However, LOCTITE® Threadlocking products fill all the voids inside the thread, allowing no room for micro-movement of the threaded fastener.

Anaerobic cure mechanism

COMPARATIVE PERFORMANCE OF LOCKING DEVICES						
LOCKING DEVICE	LUBRICITY	TORQUE-TENSION CONTROL	LOCKING PERFORMANCE	FREE-SPINNING ASSEMBLY	ADJUSTABILITY	SIMULTANEOUS THREAD SEALING
Thread-locker	Excellent	Excellent	Excellent	Yes	Poor	Yes
Plastic nut insert	Fair	Fair	Poor	No	Poor	No
Deformed nut/bolt	Poor	Poor	Poor	No	Fair	No
Plastic patch	Poor	Good	Good	Yes	Good	No
Wedge locking washers	Poor	Good	Good	Yes	Good	No
Serrated head	Poor	Poor	Good	Yes	Fair	No

TABLE 12
Comparative performance of locking devices.

Anaerobic curing is a chemical reaction that turns a liquid anaerobic threadlocker into a solid thermoset polymer. Figure 52 shows the chemical reaction simplified into four steps.

In step 1, the anaerobic adhesive is in a liquid state. The methacrylate monomers are represented by white spheres, the peroxide initiator by red spheres and the oxygen with blue diamonds. As long as oxygen can diffuse through the volume of adhesive, the adhesive will remain liquid.



See how a very tough and durable thermoset polymer is formed in LOCTITE[®]XPLORE Threadlocking course, chapter 2.

In step 2, when anaerobic adhesive is applied onto the metal surface (the bolt), the adhesive extracts metal ions. These extracted metal ions help decompose the peroxide initiators into highly reactive free radicals. In the presence of air, these free radicals react with oxygen and become unreactive.

In step 3, when the mating part (the nut) contacts the adhesive on the first part, oxygen is no longer available. Additionally, more reactive free radicals are generated, since both metal surfaces are in contact with adhesive. Under these conditions, the reactive radicals start reacting with monomers; they join; and the monomer becomes the free radical, which in turn reacts with another monomer. In this fashion, monomers are being added to form a growing polymer chain.

In step 4, these growing polymer chains eventually react either with another growing polymer chain, forming a crosslinked polymer network, or with other components of the formulation. Both reactions terminate the polymer chain growth. Thus, a very tough and durable thermoset polymer is formed.

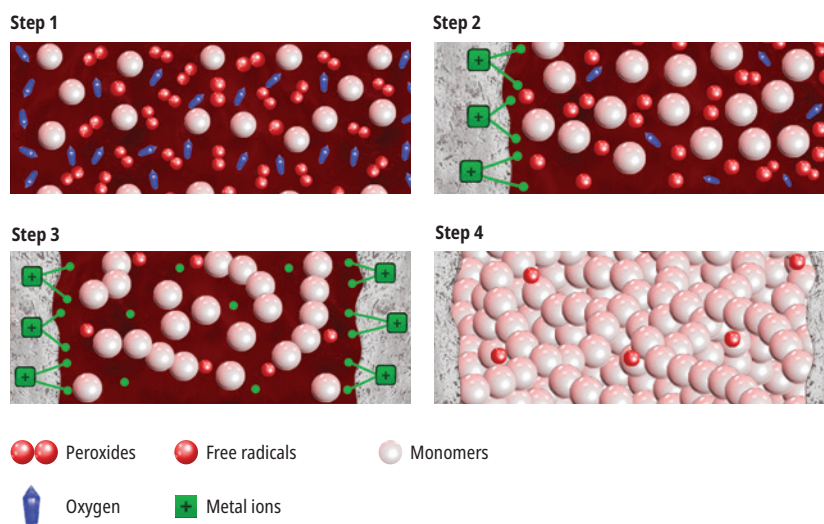

FIGURE 52 Anaerobic cure mechanism.

6.5.3

Factors influencing anaerobic curing

When designing a new process, it is important to consider the factors that affect the curing speed of an anaerobic threadlocker: substrate, temperature and gap between the substrates.

Substrates

6.5.3.1

Metal ions from the substrate are involved in promoting cure of the adhesive. Hence, metals are the most relevant substrates for anaerobic adhesives. The metal substrate should contain metal ions capable of existing in different oxidation states, for example, copper (Cu⁺, Cu²⁺) and iron (Fe²⁺, Fe³⁺). In practice, many metal substrates provide the necessary levels of these ions to effectively initiate cure of the anaerobic adhesive. Substrates can be grouped into those considered active, which provide a plentiful supply of metal ions, and those that are passive, which provide limited quantities of these metal ions. Substrates used in the manufacture of fasteners can be broadly categorized according to their activity and ability to initiate cure of anaerobic adhesives (Table 13). However, this is only intended to be a guide, as within a category such as stainless steel, activity can vary considerably.



Test several metals and see whether or not the adhesive will cure in LOCTITE[®]EXPLORE Threadlocking course, **chapter 2**.

ACTIVE	PASSIVE	INACTIVE
Copper	Low copper aluminium	Anodized aluminium
Brass	Stainless steel	Plastics
Bronze	Zinc plating	Painted and lacquered finishes
Iron steel	Zinc dichromate	Silver*
Nickel*	Hot dip zinc galvanizing	Gold*
Manganese	Zinc flake coated steels	Ceramics*
Zinc phosphate	Magnesium	
Black oxide	Cadmium	
Aluminium alloys (contains Cu)	Titanium	
	Chrome	
	Nickel*	
	Tin	
	Metal oxide	
	Chromate layers	
	Ceramics*	
	Silver*	
	Gold*	
Fast curing	Slow curing	Very slow/no curing

TABLE 13
Anaerobic adhesive cure speed and substrate activity.

*Due to differences in grades, these materials may be included in two categories

Substrate types

For anaerobic adhesives, the most important aspect to consider is the composition and cleanliness of the substrate surface. This makes it important to understand how platings or finishes may affect anaerobic curing. A fastener classified as a steel fastener could be transformed from an active substrate to a passive one if certain types of coatings are applied, for example, painting the surface. In practical terms, it is relatively easy to check the activity by conducting tests with the adhesive. In general, though, the following overview can serve as a guide for different platings and finishes.

Zinc plating

This is the most commonly used type of plating and involves deposition of a layer of zinc to the metal by electrochemical means for the purpose of corrosion protection. The finish is white to blue-grey in colour. This type of finish is generally considered passive with regard to anaerobic adhesives.

Other plating finishes

Cadmium and chrome (chromium) plating finishes are less used now due to environmental impact. Nickel plating provides a highly reflective finish with good corrosion and wear resistance. Anaerobic products generally cure well on this substrate.

Chromate

Chromate is a general term for a variety of secondary finishes applied to plating to further improve corrosion protection. A popular example is zinc dichromate, which is generated by treating a zinc plate with dichromate to produce a yellow finish. Fasteners treated in this way are less active with regard to anaerobic adhesives. Nevertheless, many anaerobic adhesives are capable of full cure on these surfaces without the need to use an activator.

Hot dip zinc galvanizing

This involves dipping parts in molten zinc. The grey coating provides excellent corrosion protection, but the coating is thick and irregular. For anaerobic products, this is a passive substrate.

Phosphate and oil

This finish is a zinc phosphate-based conversion coating combined with an oil dip for improved corrosion protection. For anaerobic adhesives, the substrate itself is active, but the oil should be removed by degreasing for optimum performance.

Black oxide

Black Oxide, or blackening, is a conversion coating that uses various processes to generate a layer of magnetite (Fe_3O_4). It is commonly used on ferrous metals for corrosion resistance. The oil present on this type of fastener should be removed by degreasing prior to use with an anaerobic adhesive. The substrate itself is active with regard to anaerobic adhesives.

Stainless steel

Stainless steel is a popular choice due to its excellent corrosion resistance properties. There are many grades of stainless steel. The 300 series is most often used to produce fasteners, with types such as 304 and 316 most often encountered. Stainless steel often undergoes a passivation process, which involves dipping in nitric acid to remove iron particles. Stainless steel can be considered a passive substrate with regard to anaerobic adhesives, although some adhesives have been developed that cure on many types of stainless steel.

Anodized aluminium

Anodizing is a process of building up an oxide layer electrochemically. Aluminium is particularly suited for this process, and the resulting anodized surface has improved resistance to corrosion. For an anaerobic adhesive, this surface is passive, and application of an activator may be required to initiate cure of the adhesive.

Zinc flake coatings

Zinc flake coatings are sacrificial coatings that contain zinc and/or aluminium elements that oxidize sacrificially to ensure the metal substrate to which they are applied remains corrosion free. In terms of application, a zinc flake coating process consists of dipping the component into a liquid bath of the coating plus an organic or non-organic binder and spinning off the excess or spraying the coating onto a part. This is followed by curing the coating at high temperature (up to 300°C (572°F)).

The use of zinc flake coatings by major OEMs (original equipment manufacturers) worldwide has increased substantially due to the requirements for prolonged corrosion resistance and improved health and safety. The following brands provide this type of coating technology: Geomet™, Dacromet™, and Magni™.

Plastics

Use of anaerobic threadlockers with polymer coated metal (i.e. powder coatings) or plastic fasteners is not recommended. These substrates will not effectively initiate cure due to the lack of metal ions unless the gap between threads is very small, in which case very slow cure may be observed. Anaerobic threadlockers can be used if one of the threaded parts is metal and the other one is plastic. However, proper testing needs to be carried out to verify sufficient adhesion and integrity of the plastic. Anaerobic threadlockers can attack certain plastics and lead to stress cracking. If both threaded parts are plastic, consider using a cyanoacrylate-based adhesive.



FIGURE 53
Different bolt substrates and coatings.

- a. Clear zinc
- b. Zinc dichromate
- c. Zinc flake coated
- d. Hot-dip galvanized
- e. Black oxide
- f. Brass
- g. Stainless steel

6.5.3.2

Temperature

A threadlocker's cure can be accelerated with increased temperature. Figure 54 shows typical threadlocker cure profiles for room temperature, elevated and lower temperatures. There are limitations to how high/how fast this accelerated cure can be achieved, as above about 150°C (302°F), some chemical components will evaporate and be lost. Heat may also be used to cure anaerobic threadlockers on passive substrates where an activator is not desired. It is important to check the temperature of parts rather than relying on air temperature, as metals may not be equilibrated to room temperature. Additionally, the effect of temperature on viscosity must be considered. At lower temperature, viscosity will be higher, and the threadlocker may not spread on parts as easily as at room temperature. If the product is in paste form, it may be difficult to apply at a lower temperature.

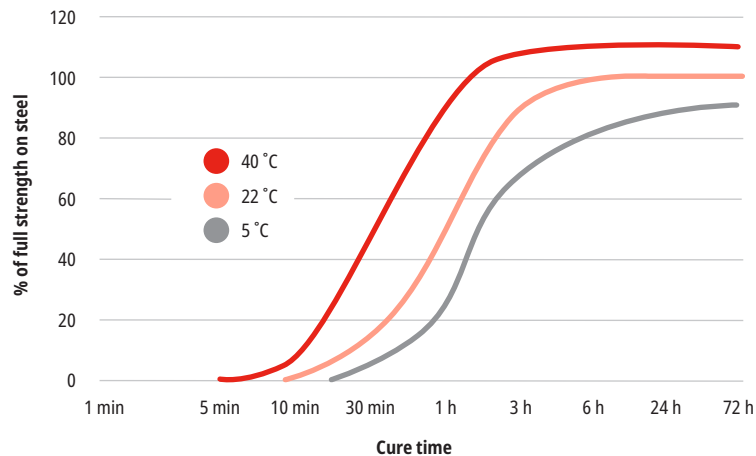

FIGURE 54
Typical temperature dependence of cure behaviour.

6.5.3.3

Gap between the substrates

The curing reaction of the adhesive is slower in larger gaps. Due to the complexity of threaded fasteners, the bond gap is difficult to measure. Machined pin and collar specimens with defined gaps were bonded using a threadlocker, and the shear strength of the assemblies were tested to display the concept of cure speed vs bond gap. Threadlocker adhesive needs the metal ions from the substrate surface in order to cure effectively. Larger bond gaps lead to slower diffusion of the metal ions through the adhesive. For assemblies with large gaps, an activator can be used to reduce cure times.

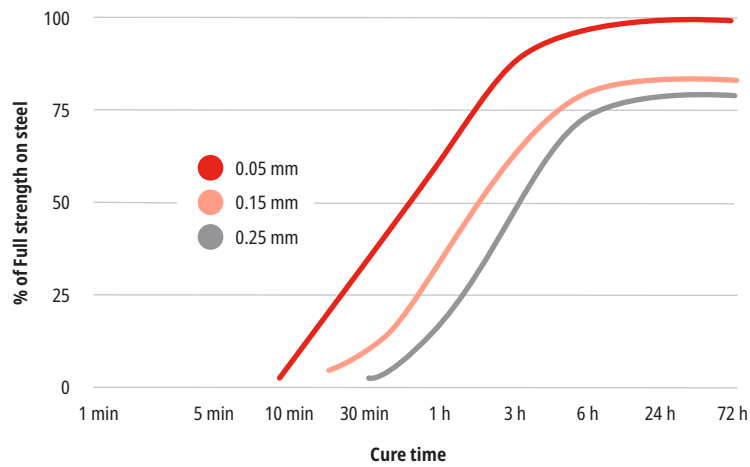

FIGURE 55
Effect of bond gap on cure speed.

Surface preparation for threadlockers

6.5.4

Correct surface pre-treatment is necessary for optimum bonding. Bond strength is determined to a great extent by the adhesion between the joint surfaces and the adhesive, so it's important to clean surfaces thoroughly. The more thoroughly the surfaces are cleaned, the stronger the adhesive joint will be.

Complete removal of oil, grease, dust and other residual dirt from the bond surface is required for optimum bond strength. Solvents that evaporate without leaving residues are suitable for this. Alkaline or acid-based aqueous cleaning systems almost always contain corrosion inhibitors. If these remain on the cleaned bond surfaces, they may reduce the adhesion of the adhesive. If such cleaning systems are to be used, preliminary tests should always be carried out. In every case, substrates must be thoroughly rinsed or wiped off.

If special degreasing baths are used for larger production runs, it is advisable to pre-clean very dirty surfaces so the cleaning batch is not contaminated.

Manual cleaning

For manual cleaning, apply a fast evaporating cleaner from its container (pump spray or aerosol) and wet a white, lint-free cloth. Wipe the cloth in one direction only, not back and forth. For nuts and bolts, wrap the cloth around the threads and turn the fastener. Clean the part until it no longer discolours the cloth. For through holes or blind holes, apply cleaner and clear the hole with clean, dry compressed air. It is possible to assist the chemical degreasing process by separating dirt from the surface through mechanical action, for example, by rubbing with a stiff brush.

FIGURE 56
Cleaning a bolt with
LOCTITE® cleaner and
wipe.

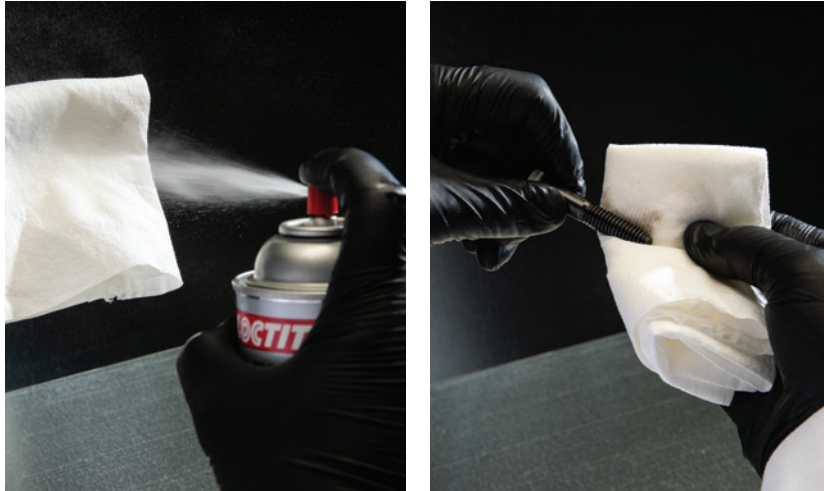

Reuse of a fastener with threadlocker

When a threadlocked bolt is disassembled and needs to be reused, cured threadlocker will need to be removed from the bolt threads. Cured product can be removed with a combination of soaking in a solvent and mechanical abrasion such as a wire brush.

FIGURE 57
Cleaning a bolt with a
brush.



Chemical preparation: Activators

6.5.4.1

One approach commonly used to improve the performance of LOCTITE® Threadlocker on certain lower activity metals and/or to increase the depth of cure, is to treat the substrate with a solution of a transition metal compound and/or an activator in a volatile solvent.

For some adhesives, an activator is necessary to initiate curing, while for anaerobic threadlockers, the activator is an option to ensure full cure on passive substrates or speed up curing. Unlike primers, activators normally do not improve the adhesion but improve the cohesion of an adhesive by guaranteeing cure.

Activators can be solvent based or solvent free. The activator is applied on one surface, for example on the through hole or on the nut, and the adhesive is applied on the other surface, for example on the bolt thread. The curing process begins immediately after two parts have been joined. The time until the assembly reaches operating strength depends on the adhesive reactivity, the substrate, the gap and the environmental temperature.

Activators for threadlocking adhesives are used for:

- Passive substrates
- Cold temperatures of < 5°C (41°F)
- Curing through larger gaps
- Accelerating cure speed

Activators are particularly useful on passive substrates such as stainless steel, zinc-plated bolts or zinc flake coatings, etc., as they are also used to initiate the curing process and provide a more robust cure.

In assembly processes, activators are also used to increase cure speed on active metal substrates and to achieve operating strength faster, for example to make it possible to move assembled parts from one assembly station to the next assembly station without affecting the bond line.

At cold environmental temperatures, for example in the field for maintenance and repair applications, the cure speed of anaerobic adhesives can become unacceptably long. This is a phenomenon that affects most polymers because the reactivity of polymer crosslinking processes drops at cold temperatures.

6.6

Application of product



True or False: Wicking grade is the preferred solution for overhead assemblies?

See the response in **chapter 3** of **LOCTITE[®]XPLORE** Threadlocking course.

The application of threadlocker to threaded fasteners is an important consideration for performance. For maximum reliability, the clearance between the engaged nut and bolt should be filled with the adhesive. Depending on the configuration of the assembly, different techniques are needed.

Standard nuts/bolts and through holes

Apply a liquid threadlocker onto the bolt and proposed tightened nut engagement area. To apply a semi-solid threadlocker, completely fill the root of the bolt threads at the engagement area. Any excess threadlocker is pushed along with the nut as it is tightened. The volume of threadlocker needed depends on the size of the fastener and engagement area. A few free-falling drops is a typical volume required for an M10 or 3/8" bolt. A minimal amount of threadlocker squeezing out from the nut and bearing surface interface indicates that a sufficient volume of product has been used to fill the clearance. If an assembly is particularly susceptible to galling, additional threadlocker may be used along the length of the bolt to lubricate the threads as the nut is threaded on.

FIGURE 58
Proper application of threadlocker on a through hole. Placement of threadlocker must be closer to the end of the bolt.

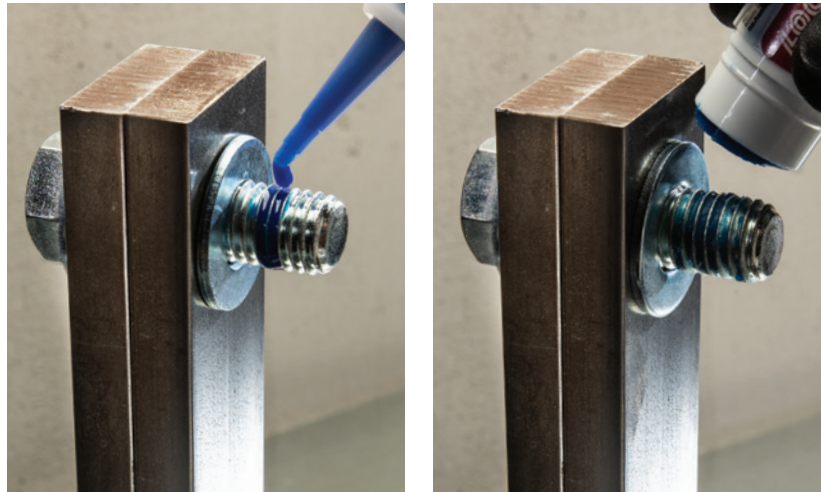

Post assembly

When a threaded assembly has already been assembled and torqued to the target clamp load, a wicking grade threadlocker can be used. This is particularly suitable for locking adjustment and/or set screws or for preventative maintenance on existing equipment. Product should be applied at the nut and bolt junction, as shown in Figure 59. Avoid touching the bottle tip to the metal.



FIGURE 59
Proper post assembly application; wicking threadlocker.

Blind hole

Improperly applied threadlocker in a blind hole application can cause incomplete coverage of the engaged threads. When product is only applied to the bolt, the liquid threadlocker creates a seal with the female threads and traps air. As the air resists compression, it escapes by pushing threadlocker out through the clearance when the bolt is further engaged, which prevents the threadlocker from entering the blind hole and properly coating the threads. For blind hole applications, drops of liquid threadlocker should be applied down the female threads into the bottom third of the hole or the bottom of the hole. Once the bolt threads become engaged with coated blind hole threads, the air will push threadlocker towards the exit of the hole, creating proper coverage. To ensure complete coverage, it is suggested that threadlocker also be applied to the threads where the threads of the nut and bolt are engaged, as shown in Figure 60.

In rare circumstances, tightening of a fastener into a blind hole can cause hydraulic fracturing of the casting. The incompressible liquid threadlocker at the bottom of the hole will need to flow up the threads to escape. Greases, anti-seize lubricants and high viscosity threadlockers will resist flowing out and for this reason are not recommended for blind hole applications unless assembly speeds are very low. High speed on-torquing devices such as impact guns are best avoided for tightening fasteners into a blind hole, as it will create shock loads.

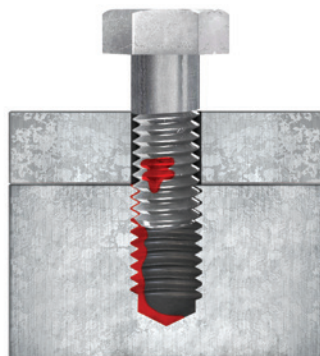

FIGURE 60
Correct application of threadlocker in a blind hole.

6.6.1

Properties of threadlockers

Threadlocker properties in an uncured state influence how the product performs when being applied to nuts and bolts, while the properties in a cured state relate to the performance of bonded assemblies in their service environments.

6.6.1.1

Uncured threadlocker properties

Viscosity

Viscosity is a measure of resistance to flow at a given shear rate. It is one of the most important properties to consider in choosing a product. Threadlockers have viscosities ranging from thin, like water, to semi-solid. Some threadlocker products are designed as thixotropic liquids, which do not flow without shear force, preventing drips, but thin out when nuts and bolts are assembled.

Oil tolerance

For optimal adhesion, surfaces should be clean and free of contaminants. However, it is not always realistic to have completely clean surfaces. Many LOCTITE® Threadlockers can still cure and adhere on lightly oil-contaminated surfaces. Testing has demonstrated compatibility with engine oils, corrosion prevention oils and cutting fluids, which are the most common contaminants found on nut and bolt surfaces.

Lubricity

How lubrication reduces torque-tension scatter is described in section 6.3.3. Some LOCTITE® Threadlockers have additives that help lubricate the assembly as well as oil and grease. However, the effect of this property is dependent on the threaded fasteners used in the assembly.

Fluorescence

Threadlockers may contain additives that are fluorescent under UV light. This acts as a quality control or troubleshooting tool to check whether the threadlocker product was used during the assembly.

Cured threadlocker properties

The performance of threadlocker products is tested using standardized nuts and bolts. The majority of those tests are listed below.

Break-away torque

The torque required to break the bond between the nut and the bolt when rotating an unseated assembly is known as 'break-away torque'. For this test, standardized nuts and bolts are assembled using a threadlocker product. The nut is screwed on to expose 2-3 threads on the bolt tip (shown in Figure 62). This unseated assembly is then cured for a specific time period at a specific temperature. The torque required to break the bond between the nut and the bolt is measured using semi-automated torque measuring equipment.

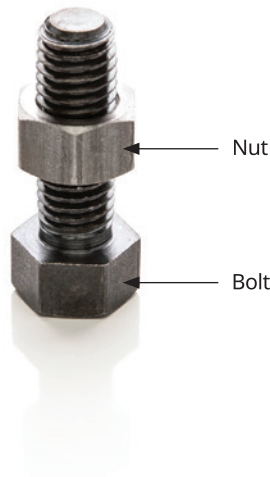

FIGURE 61
Assembly for break-away torque measurement.

Break-loose torque

Similar to break-away torque, break-loose torque reflects the torque required to break the bond between a standardized nut and the bolt in a seated assembly, typically torqued to 5 N.m. While break-away torque is an indicator of threadlocker strength alone, break-loose torque is more relevant to the clamp load and friction involved in a real-life fastener application.

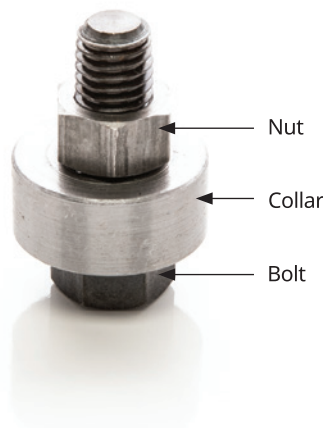

FIGURE 62
Assembly for break-loose torque measurement.

Prevailing torque

After the initial breakage of the bond, the average torque measured during the 360-degree rotation of the nut is known as ‘prevailing torque’. This torque is measured after the break-away or break-loose torque measurement. A typical output from the break torque measurement is shown in Figure 63. The Y-axis in the plot is the measured torque, and the X-axis is the revolution of the nut measured in degrees. As seen in Figure 63, even after the initial break, there is continued resistance to the nut rotation. The prevailing torque value is normally measured at 180 degrees of rotation.

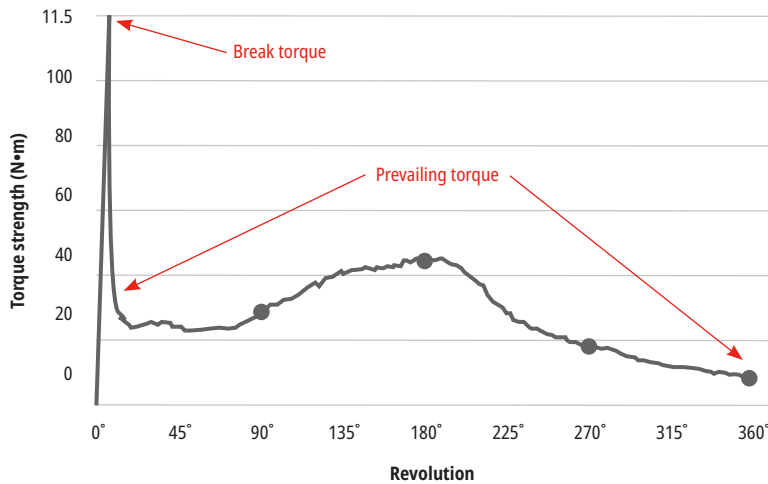

FIGURE 63
Break-torque and prevail-torque.

Shear strength of threadlockers

Shear strength in a threadlocker is the shear force required to break the threadlocker adhesive bond. High tolerance pin and collar test specimens are used to perform this testing. Detailed information regarding this testing is provided in section 12.6.2. While torque testing uses rotational force to evaluate the adhesive strength in a threaded assembly, this test uses compressive force to push an unthreaded pin that is adhesively bonded to the inner diameter of a collar. Due to the high dimensional tolerances of the specimens, this method provides the best estimate of the true shear strength of threadlockers.

Torque augmentation

Torque augmentation compares the break-loose torque of an untreated assembly when tightened from 0–90% proof load to the break-loose torque of the same assembly with a locking device. This is an important characteristic that describes how much torque it will take to disassemble a standard bolt and nut assembly when they have been tightened. Threadlockers provide a controlled increase in torque depending on the selected threadlocker strength, whereas most locking devices do not provide torque augmentation.

The value is normally described as a percentage but can also be measured as an absolute torque value increase. In section 6.3.2, we saw that the normal break-loose torque of a coarse thread bolt is approximately 70% of the torque that has been applied (for a fine thread bolt, the value is approximately 80%). Once cured, a threadlocker will provide torque augmentation in relation to the strength of the threadlocker. The break-loose torque of low strength threadlockers only increases by approximately 3% over untreated fasteners when tightened to 75% proof load. Medium strength threadlockers provide torque augmentation of approximately 25%, and high strength threadlockers provide approximately 40–75% augmentation depending on other factors.

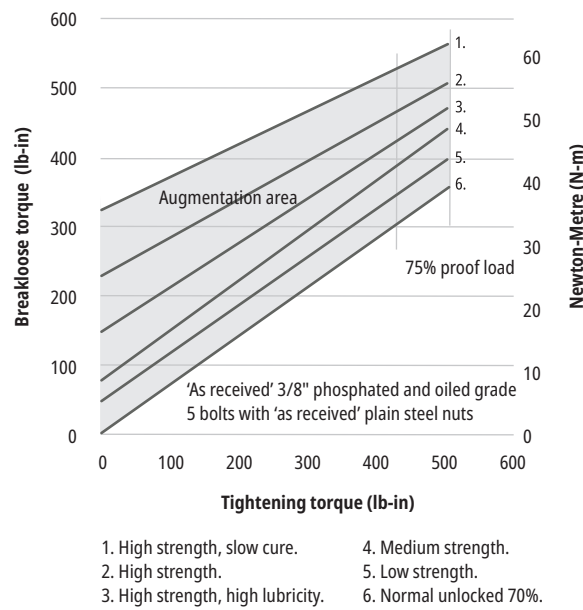

FIGURE 64 Torque augmentation.

Temperature resistance

The effect of high temperature on threadlocker strength is assessed based on hot strength, where a cured assembly is tested at a desired temperature, and heat aging, where a cured assembly is heat-aged at the desired temperature and for the desired time, then tested at room temperature.

Hot strength

The break-away or break-loose torque measured at an elevated temperature are reported as their hot strength. Usually, assembled and cured nuts and bolts are left in the oven for 1–2 hours before they are measured. This is to ensure that the entire assembly is heated to the desired temperature. Figure 65 plots the results of multiple tests to show the effect of temperature on strength. This testing shows that the threadlocker has the strength to prevent bolt loosening at elevated temperatures.

FIGURE 65
A typical hot strength plot for a threadlocker product.

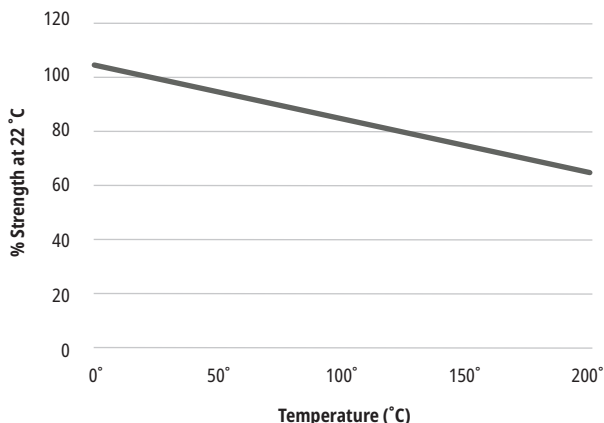

Heat aging

Assembled and cured nuts and bolts are aged for the time (as shown on the X-axis in Figure 66) at a desired temperature. Aged assemblies are removed at specific time points and allowed to cool down to room temperature before break torque measurement. A typical heat-aging plot reported on a technical data sheet is shown in Figure 66.

FIGURE 66
A typical heat aging plot for a threadlocker product.

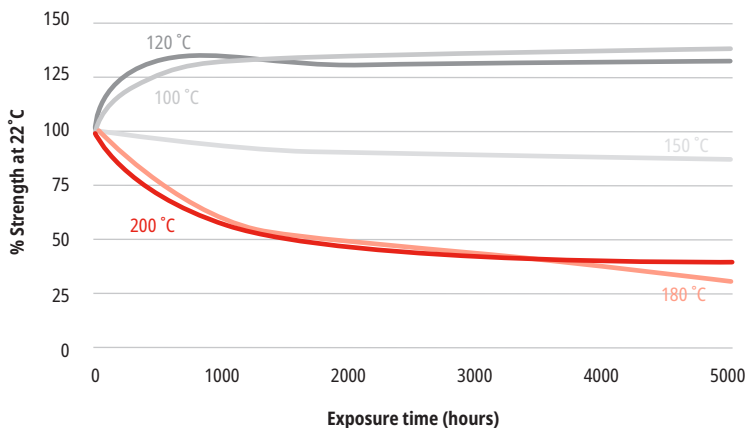

In some cases, hot strength and heat aging tests are combined. In this test, samples are aged at elevated temperatures and tested at the aging temperature at specified time intervals, as shown in Figure 67.

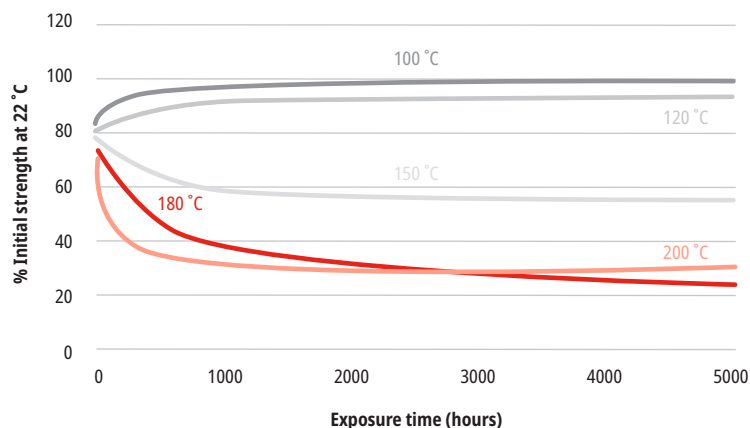

FIGURE 67
A typical heat aging/
hot strength plot for a
threadlocker product.

Environmental resistance

A bolted assembly is often exposed to various environmental factors and/or chemicals in its service life. For testing the effect of these factors, the nut and bolt assembly is exposed to the appropriate environmental conditions or chemicals and the break-away torque is measured after a certain period of exposure. For many threadlocker products, this data is reported on the TDS. A typical example of a chemical resistance table is shown in Table 14.

ENVIRONMENT	°C	% OF INITIAL STRENGTH		
		500 h	1000 h	5000 h
Motor oil	125	110	115	115
Unleaded gasoline	22	100	95	100
Brake fluid	22	105	110	125
Water/glycol 50/50	87	120	125	130
Acetone	22	85	85	80
Ethanol	22	95	90	90
E85 Ethanol fuel	22	95	100	95
B100 Bio-diesel	22	110	110	125
DEF (AdBlue®)	22	61	59	70

TABLE 14
Chemical and
environmental resistance
of cured threadlockers.

6.6.2



To find the right product, use our **Product Selector Tool** in **chapter 4** of the Threadlocker LOCTITE[®]XPLORÉ e-learning course.

Product selection

It is critically important to understand the exact requirements of an application in order to provide the best solution. One must consider variables that affect the assembly process as well as variables that affect the performance of the threadlocker during the equipment's service life.

How strong does it need to be?

The strength of a threadlocked assembly is one of the most important considerations for selection. Strength is directly related to how much surface area is bonded by the threadlocker. There is a full portfolio of products to meet the strength requirements of various applications.

Does the assembly need to be removable?

If threaded fasteners were designed never to be removed, then only one threadlocking compound would be needed: the strongest available. Most assemblies that are held together with threaded fasteners, however, will at some time be dismantled for repairs, maintenance or adjustments.

Screws are normally tightened using slots or recesses in the head of the screw. The physical size of the slot limits the amount of torque that can be applied to the fastener without causing damage. Furthermore, screws usually have long threaded sections, resulting in large engagement areas. Using a high strength threadlocker under these circumstances will result in the screw being permanently locked into the job. Attempts at removal will usually result in broken screws or damaged screw-head recesses. The torque augmentation capability of low shear strength threadlockers is such that the resulting break-loose torque is only approximately 3% greater than that of an untreated assembly when tensioned to 75% proof load. Where only low assembly torque is used (screwdriver tight), the augmentation percentage will be higher without exceeding fastener torsion strength during disassembly.

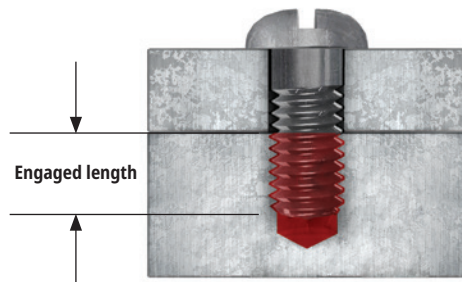

FIGURE 68 Engaged length.

Threadlockers used on nuts and bolts are usually higher strength grades than those used for screws. This is because of the relative size of these fasteners and the methods of assembly (i.e. wrenches and sockets), which allow for more torque to be applied without damage to the fastener.

In addition, the amount of thread engagement area is reduced. The usual length of engagement for standard nuts and bolts is generally somewhere in the range of 0.8–1.0 times the nominal diameter of the bolt. This, in turn, means that the threadlocking medium must be of a higher strength in proportion to the surface area it acts on. Medium-strength threadlockers will provide torque augmentation approximately 25% greater than the break-loose torque of untreated fasteners when tensioned to 75% proof load. This latter value is generally equal to or slightly higher than the recommended tightening torque for the fastener. This is not applicable for bolts threaded into tapped holes, where the engagement length may be much higher.

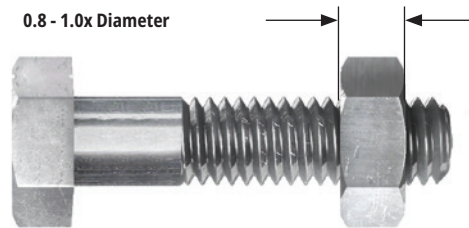

FIGURE 69
Engagement-to-diameter ratio.

Studs and highly stressed fasteners usually require threadlockers that offer a greater locking strength than those used for nuts or screws. Break-loose torque is significantly higher than for untreated fasteners when tensioned to 75% proof load. Torque augmentation is around +40 to +55%.

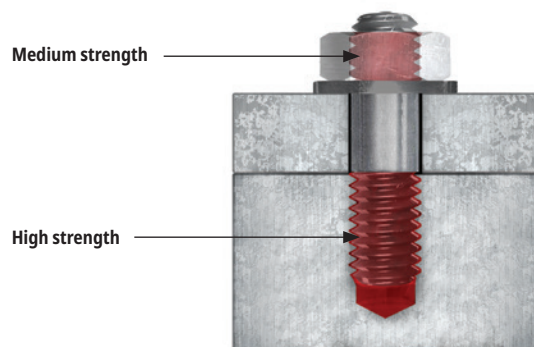
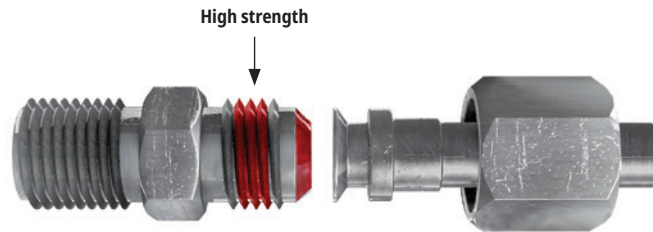

FIGURE 70
Stud locking.

The highest strength threadlockers are recommended in applications where extra chemical resistance is required, such as in refrigeration fittings and assemblies where aggressive solvents are encountered.

FIGURE 71
Refrigerant fitting.



Another type of product that possesses outstanding chemical resistance properties is the slow curing, high viscosity, high-strength threadlocker. The higher viscosity improves its gap-filling abilities. These tend to have the highest shear strength of the threadlocking grades, and torque augmentation increases roughly 75% over the break-loose torque for similar untreated fasteners when tensioned to 75% proof load.

How fast does it need to cure?

An assembly operation can take only seconds, or it can take hours. The cure speed of the threadlocker can be an important criterion. Additionally, since the surfaces, temperature, gap and cleanliness all have an impact on how fast a threadlocker will cure, each of these parameters must be considered.

What are the fastener materials?

Active metals will cause the threadlocker to cure faster than passive metals. Adhesion to the fastener material may also vary the full cured strength of the assembly. Some products are more sensitive to the surface activity than others. Cure speed vs substrate curves on the technical data sheet provide guidance for this decision. The use of an activator may be required when passive and inactive metals have been specified or when cure speed needs to be accelerated.

How long does the assembly operation take?

If an assembly operation is very fast, it is important to consider whether the threadlocked assembly needs to be cured sufficiently before proceeding to the next step in the assembly. For a clamped assembly, the metal-to-metal friction often provides handling strength, but heat curing or use of an activator can reduce cure times.

Does the assembly require a torque sequence?

For many precisely tensioned assemblies, a torque sequence may be specified in the tightening procedure. Some of these operations can take minutes or even hours for large equipment. If a threadlocker cures too quickly, it will add friction to the assembly process. Slow curing threadlockers are best suited for these applications.

What's the right viscosity?

For most applications, a low to medium viscosity threadlocker is well suited for direct application to a nut or bolt; however, in some circumstances, viscosity becomes a primary consideration in product selection.

Is the joint pre-assembled?

If the components are pre-assembled, the viscosity of the threadlocker will be a primary consideration. The threadlocker will need to wick into the threads by capillary action, and this requires a wicking grade viscosity.

Are the parts overhead?

When parts are in an orientation where a liquid would drip off the part, a high viscosity or semi-solid material would be preferred.

What diameter are the fasteners?

Threaded fasteners are designed with some clearance between their mating surfaces. As standard bolts have larger clearances between their mating surfaces, they require more product to fill them. The thixotropic, high viscosity or semi-solid varieties will easily fill the clearances in threaded fasteners without migrating to other areas of the assembly.

What are the health and safety requirements?

As adhesive threadlocker is a chemical product, health and safety protocols must be considered. The SDS of any threadlocker should be reviewed before use, and exposure limits for workers should be assessed. Threadlockers are generally considered low-risk chemicals. However, some grades of threadlockers have few health and safety concerns. These formulas do not compromise on performance. Innovation in this area is continuous to keep up with changing standards and regulations.

How will it be applied?

There are several different ways to apply a threadlocker depending on the situation. A complete procedure should not only specify the product to be used but the method by which it is best applied. If threadlocker is applied to a through hole, blind hole or post-assembly, different methods of application are needed to ensure optimum performance (see 6.6). Automated, semi-automated or manual dispensing equipment can also be used for applying threadlocker and involve a separate list of criteria. An overview of dispensing is covered in the next section.



QUIZ!

As a rule of thumb, threadlocker cures within 90 minutes?

To see if you were right, go to **chapter 2** of the Threadlocker LOCTITE[®]XPLOR^E e-learning course.

What are the environmental conditions after cure?

When it comes to the cured performance of a threadlocker, the major considerations are the self-loosening resistance the threadlocker provides and whether the threadlocker will be able to function given the environmental factors, chemical resistance and temperature resistance. LOCTITE® anaerobic products will generally resist water, natural or synthetic lubricating oils, fuels, organic solvents and refrigerants. The cross-linked thermoset polymer is particularly stable in view of the geometry of the connection in which they are normally used. As applied to closely fitting metal parts, usually only a feather edge of cured material a few tenths of a millimeter in thickness is exposed to any working fluid, even in high-pressure sealing applications. Consequently, even the turbulent action of solvents will not erode the hard, cured resin during the life of the assembly.

LOCTITE® Threadlockers, like most organic materials, lose strength at elevated temperatures. Most show significant strength retention at temperatures up to 150°-180°C (300°-360°F). High temperature formulations can offer working temperatures to 230°C (450°F).

6.7

Validation of assemblies

Throughout the design process, testing can be performed to help validate various performance characteristics, leading to stronger and more reliable final assemblies. To establish real-part data on developmental product prototypes, Henkel offers comprehensive engineering tests and evaluation capability on customer parts or simulated customer parts. Henkel also has long-term and dynamic test capabilities for simulated or real customer parts.

Performing k-factor or coefficients of friction testing to accurately determine the tightening torque specification leads to an assembly with the desired clamp load. Knowing that assemblies are exposed to different conditions, testing can also be performed to better predict final performance.

Due to the complexity of the response that vibrations create on a structure, experts believe that testing for vibration resistance on a simulated joint is not sufficient. The unknown interactions and factors of a simulated joint may give misleading results. If possible, the test should be repeated with the actual joint.

How they work. Why they fail. And how to prevent it.



Section 7

DISPENSING

A variety of dispensing options **to accommodate a range of applications.**

Why dispensing equipment?

7.1

Dispensing equipment enables the controlled and accurate application of liquid adhesives such as threadlockers. Using dispensing equipment will provide the following benefits:

- Better quality
 - Improved accuracy of volume dispensed
 - Improved placement accuracy of dispensed adhesive
 - Improved repeatability
- Reduced cost
 - Correct volume applied means less wasted adhesive
 - No excess means less clean up and scrap
 - Better application process leads to improved efficiency
- Improved health and safety
 - Reduced operator contact with the adhesive

Henkel operates on a total solution approach that provides the following benefits:

- Unique individualized customer-centric solutions
- One source for all your needs
 - One supplier for the adhesive
 - One supplier for the dispensing equipment
 - One supplier responsible for the overall application
- The component parts in our equipment that contact the adhesive have been selected for best compatibility with the adhesive technology
- Having the right materials for the adhesive provides confidence that the equipment is the right choice for the adhesive and application
- Henkel becomes an extension of a customer's engineering resource pool for all their needs:
 - Adhesive
 - Equipment
 - Testing
 - Product design

7.2

Dispensing technology

There are two main types of liquid dispensing technology:

1. Pressure/time dispensing
2. Volumetric dispensing

7.2.1

Pressure/time dispensing

Pressure/time systems work by applying air pressure to transport the adhesive from container to dispenser tip. The adhesive is then dispensed for a set time. There are two main types of this system, and each one is suitable for different types of pack sizes. The two main types are:

1. Syringe dispenser – small pack sizes, typically 30 ml
 - Air pressure is applied through the top of the syringe, which pushes the piston/plunger towards the bottom of the syringe, dispensing the adhesive out of the dispenser tip.
 - No air pressure is applied when not dispensing.
 - A vacuum suck-back valve can be applied to the syringe after dispensing so the adhesive is drawn back up the dispenser tip, which prevents drips (2–3 mm max).
 - The amount of liquid that is dispensed can change as the syringe empties. This is because the space behind the plunger increases and takes longer to fill with air.
2. Two-litre reservoir – larger pack sizes, 250 ml up to 2 l
 - Adhesive bottle is placed directly into the reservoir.
 - Air pressure is applied to force the adhesive from the bottle up the product feedline to the dispenser valve.
 - Low level indicators ensure the adhesive level in the reservoir is monitored to prevent operation when empty.

A variety of dispensing options to accommodate a range of applications.



FIGURE 72
Pressure/time
dispensing system
diagram.

The dispensed volume is influenced by the following factors:

- Pressure
- Time
- Viscosity (batch or temperature variation)
- Valve stroke (valve dependent)
- Needle diameter

The correlation between adhesive viscosity and temperature is quite clear: as temperature rises, viscosity drops (Figure 73). Despite variable viscosity, pressure/time dispensing is suitable for most threadlocking applications. When extremely high accuracy is required, alternative volumetric dispensing equipment should be considered.

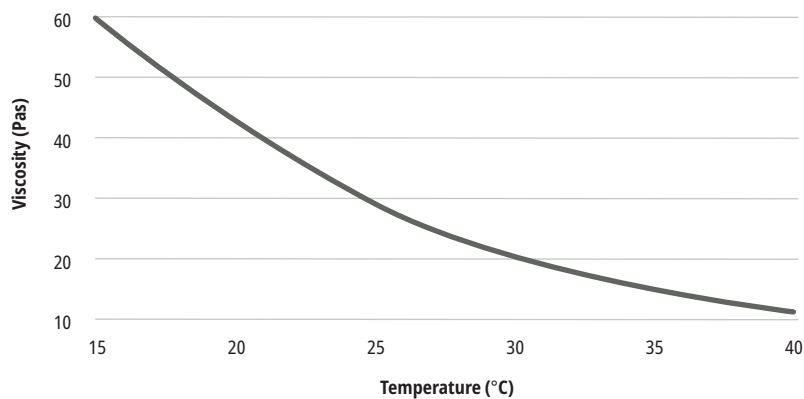

FIGURE 73
Temperature viscosity
relationship.

TABLE 15
Advantages and disadvantages of pressure/time threadlocking dispensing systems.

PRESSURE/TIME DISPENSE	
ADVANTAGES	DISADVANTAGES
<ul style="list-style-type: none"> • Easy setup and simple to operate • Reliable, low maintenance • Suits standard LOCTITE® bottles • Suits all viscosities to 100,000 mPa • Lower cost 	<ul style="list-style-type: none"> • Not volumetric • Volume dispensed affected by temperature • Volume dispensed affected by viscosity • Approximate rule—An increase of +10°C in temperature reduces viscosity by 50%

7.2.2

Volumetric dispensing

Volumetric dispensing systems are designed to positively displace a given volume of adhesive each cycle. This method of dispensing eliminates the variations in dispensed volume experienced due to viscosity changes that may be observed with pressure/time systems.

There are two types of volumetric systems:

1. Peristaltic pumps
2. Progressive cavity pumps

7.2.2.1

Peristaltic pumps

Peristaltic pumps are commonly used for precise dispensing of fluids. This can be seen by their use in hospitals for administering fluids and medications. They are ideal for adhesives, as the adhesive is contained within a feed line with no direct contact with any moving parts.

Peristaltic pumps work as follows:

- The product tube is alternately compressed and relaxed.
- Rotating rollers pass along a length of the tube, compressing it completely. This creates a seal between the input (suction) and output (discharge) sides of the pump.
- The relaxing of the tube creates a strong vacuum, which draws the adhesive up to the pump.
- The adhesive does not come into contact with any moving parts.
- This pump is a volumetric pump and thus, dispenses accurate volumes.

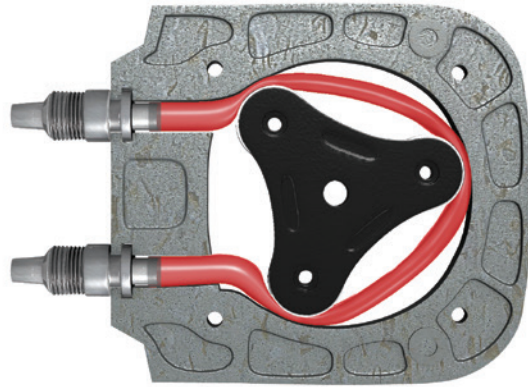

FIGURE 74
Internal workings of peristaltic dispensers.

Progressive cavity pump

7.2.2.2

LOCTITE® uses a progressive cavity system known as an eccentric rotor pump. This works on the following principles:

- A rotor, also known as an auger or an Archimedes screw, has a defined number of small cavities of a fixed shape and volume.
- As the rotor rotates, it interfaces with a stator, which has a female Archimedes screw thread that is offset to that of the rotor. The defined amount of adhesive is moved from one cavity to the next until it is expelled from the dispenser's tip.
- This means the volumetric flow rate is proportional to the rotational speed of the rotor.
- This makes it virtually independent of fluctuations caused by temperature and viscosity.
- Low pressure air feed can be used, as the pump is self priming.
- They can be adjusted to provide a controlled flow rate or precise drop size. This is achieved by a separate control unit.
- There are different versions based on minimum volume dispensed and flow rate.



FIGURE 75
Progressive cavity pump.

The dispensed volume is influenced by the following factors:

- Rotation speed
- Duration of rotation

The graph below shows that the volumetric system is independent from temperature changes and has improved accuracy and repeatability compared to a pressure/time system.

FIGURE 76
Dispense volume comparison between pressure/time and volumetric dispensing.

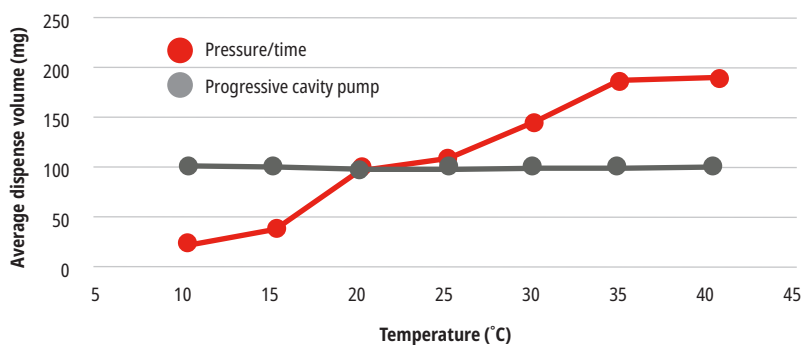

TABLE 16
Advantages and disadvantages of volumetric dispensing system.

PROGRESSIVE CAVITY PUMP	
ADVANTAGES	DISADVANTAGES
<ul style="list-style-type: none"> • Volumetric • Accuracy +/- 1% • Repeatability > 99% • Accurate and adjustable flow rate control • Seal-sealing, suck-back to prevent dripping • Easy to replace parts • Used for filled and unfilled products • Suitable for low to high viscosity products 	<ul style="list-style-type: none"> • Higher cost compared to pressure/time system • Not suitable for highly abrasive products • Stator is a wear part • Requires an external motor drive

Manual dispensing

7.3

There are three main options for dispensing threadlocker using a manual process:

1. Peristaltic and progressive cavity version hand pumps
2. Digital benchtop peristaltic dispensers
3. A controller/reservoir with a valve

Manual hand pumps

7.3.1

As thread locking is primarily a small drop application, manual hand pumps are an excellent choice for quick and accurate manual application of threadlocker. They are ergonomically designed for ease of use and handling. The hand pump connects directly to standard anaerobic threadlocker bottles, enabling a quick changeover when the bottle requires replacement.



FIGURE 77
Hand pumps for manual dispensing of threadlockers.

Benchtop digital peristaltic dispensers

7.3.2

This is essentially the same principle as a peristaltic hand pump except the pump is motorized to provide more control and features. It is designed for smaller volume and pack sizes. The benefits this brings over a hand pump or pressure/time system are as follows:

- Air-free dispensing, meaning no air in the adhesive.
- Forward and reverse motor control. This means the bottle can be placed on either side of the motor, and it provides a no suck-back feature for drip prevention.
- Simple and convenient load mechanism for product tube replacement.
- Digital motor speed adjustment and display for better control.
- Digital timer display.

- Programs for multiple different parts can be stored.
- Dispensing is initiated by a finger switch on the applicator pen, by a button on the unit or by a foot switch.
- Accurate dispensing from an applicator pen.
- Ideal for small drop dispensing.

FIGURE 78
Digital benchtop
peristaltic dispenser.



7.3.3

Controller/reservoir with valve

These are pressure/time systems and work as previously described in section 7.2.1. They enable dispensing of threadlockers direct from larger bottles (250 ml). They are simple to use, reliable and low cost. A complete system includes the following items:

- A controller
- A reservoir
- A handheld valve
- A finger switch or a foot switch for dispensing the threadlocker

For ease of use and to save space, the controller and reservoir can be integrated into one unit.

The system is connected to external power and air supply. This provides control over the time and pressure used for dispensing.

A variety of dispensing options to accommodate a range of applications.

The valve is connected to the controller and actuated via air pressure. There are different types of valves designed to accommodate different viscosities of threadlocker and different flow rate capability. Handheld valves generally have a single actuator, which means they open with air pressure and close with spring force. Some valves have stroke control. This can vary the amount the valve opens, allowing either more or less threadlocker to flow through the valve.

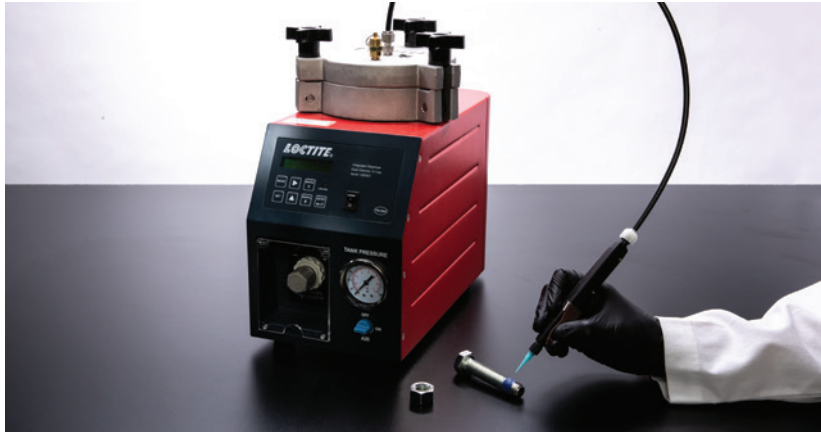

FIGURE 79
Dual channel controller.

Automated dispensing

7.4

All controllers, reservoirs and valves can be integrated into either a semi-automatic or fully automatic process. A semi-automatic process requires some input from an operator, such as presenting a bolt to a sensor, which triggers the dispensing of threadlocker adhesive from a valve onto the bolt. A fully automatic process is one where there is no input required from the operator, such as when a dispensing valve is connected to a robot and is triggered by a higher ranking controller such as a programmable logic controller (PLC).

The two main dispensing technologies used for automated dispensing equipment are pressure/time and volumetric.

7.4.1

Automated Pressure/time system

A pressure/time system requires:

- **A controller**—Integrating a semi-automated or automated process requires a more advanced controller with many more functions, such as flow sensing and a PLC signal interface.
- **A reservoir**
- **A valve**—More robust and industrial types of valves are required for this type of system.
- **Accessories (optional)**—For example, an advancing slide to move the valve into dispensing position and retract it after dispensing has occurred.

Automatic dispensing valves are connected to the controller and actuated via air pressure. There are different types of valves designed for different viscosities, flow rate capabilities and suck-back requirements. Automatic dispensing valves are available in single acting and double acting versions. The single acting valves open with air pressure and close by spring force. Double acting valves open and close with air pressure, with an additional spring closure to ensure they are failsafe and close in the event of a loss of air supply. Double acting valves have the added benefit of a suck-back feature. These valves also have stroke control to adjust the flow by varying the amount the valve opens, either allowing more or less threadlocker to flow through the valve.

A variety of dispensing options to accommodate a range of applications.

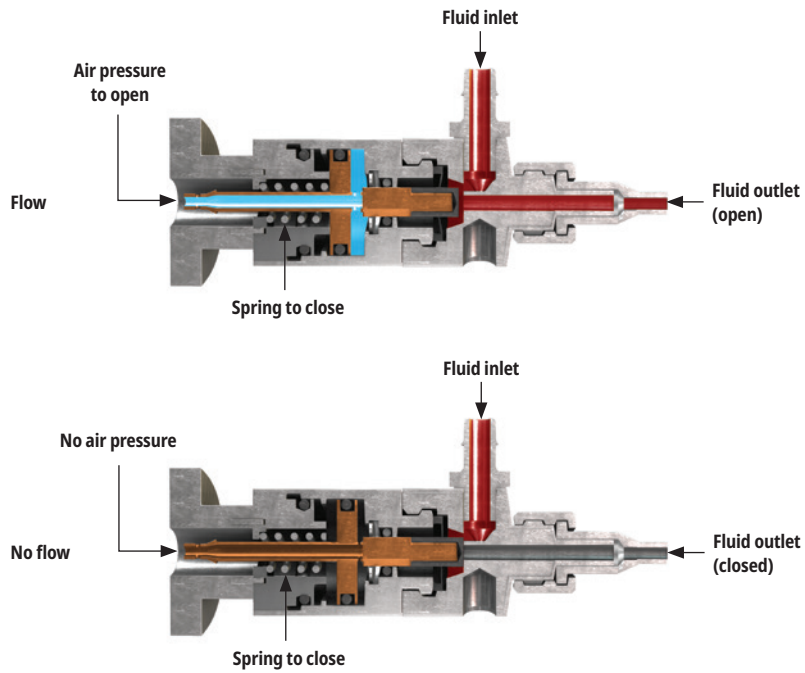

FIGURE 80
Single acting valve.

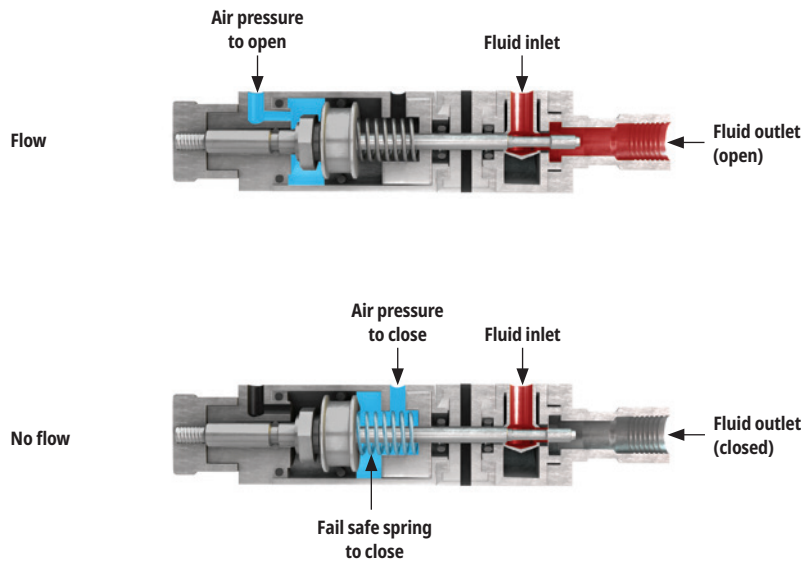

FIGURE 81
Dual acting valve.

7.4.2

Volumetric automated system

If a volumetric system is required for greater accuracy, it will require:

- **A rotor pump controller**—This controls pump speed, volume dispensed, reservoir pressure and low-level warnings.
- **A reservoir**—As in previous sections.
- **A rotor pump**—As described in section 7.2.2.2.

Figure 82 shows a volumetric rotor pump and its controller. The reservoir used would be the same as that used for pressure/time systems. As described in section 7.2.1, the rotor pump is fed by adhesive at low pressure, meaning the same reservoir can be utilised.

FIGURE 82
Reservoir/controller and volumetric pump system utilized for the automation of threadlocking adhesives.



7.5

Equipment selection

When selecting the appropriate dispensing equipment, there are a few things that need to be considered. Automated systems generally use pressure/time, as described in section 7.2.1, or volumetric for higher accuracy, as described in section 7.2.2.2. Knowing how many valves or rotor pumps need to be controlled and the accessories that are required for the dispensing system can also help determine equipment needs. For example, two valves running at the same time for a quick cycle time will require a controller that can control two valves simultaneously. Some other considerations are listed below.

- Volume of adhesive required per component
- Accuracy of volume dispensed
- Yearly volume of components

A variety of dispensing options to accommodate a range of applications.

- Cycle time
- Number of valves/rotorpumps
- Accessories required
- Semi-automation or full automation required
- Part geometry
- Product viscosity
- Cost/budget

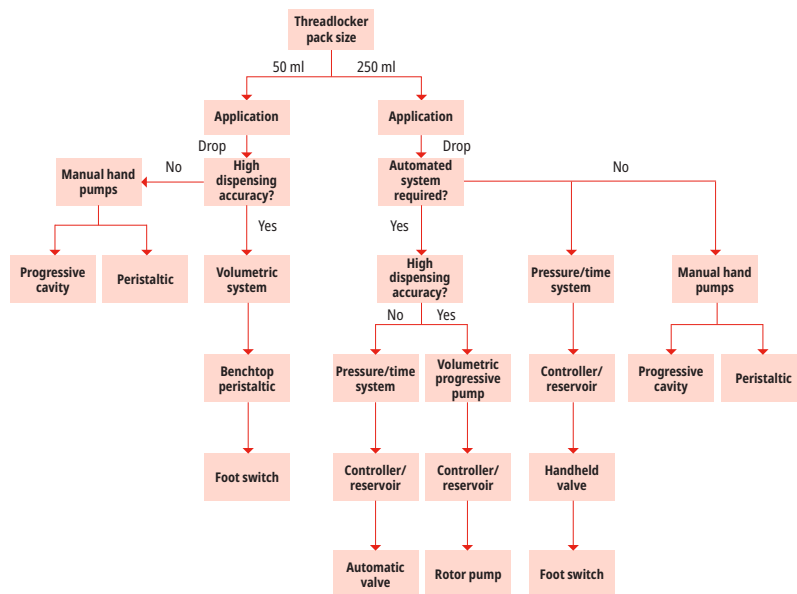



FIGURE 83
Decision tree on best dispensing method.



Section 8

TROUBLESHOOTING

How to diagnose—and prevent—**bonding challenges.**

LOCTITE[®]
1507

When a failure arises in a bonded joint, it is important to troubleshooting to understand the root cause of the issue so it can be avoided in the future. Three key areas should be investigated: parts, process and product (3Ps).

Parts

What does the failure look like? Failure mode analysis is a key aspect of bonded joint troubleshooting, and the subject will be covered in section 8.1.

Process

How was the product applied?
How were the parts assembled?
How was the adhesive cured?

Product

Was the product within its shelf life?
How was the product stored?
Has the failure occurred in multiple batches or lots?
Is this the correct product for the application?

Continued questioning is an important part of troubleshooting to fully understand the problem. Ask yourself ‘what do you actually know?’. Avoid making assumptions in answering each question.

Failure mode analysis

8.1

When assessing the performance of an adhesive by destructive testing or troubleshooting a failed assembly, the most valuable observations that can be made are of the failure mode. There are three main adhesion failure modes: adhesive failure, cohesive failure and substrate failure.

Adhesive failure

Adhesive failure occurs when the bonded assembly is subjected to a load that exceeds the adhesion, causing failure at the interface of the adhesive and the bonded parts. This failure mode is visible by the adhesive residue remaining on one of the two parts. In the case of a threadlocker, the adhesive would be completely stuck to either the male or female thread, as shown in Figure 84.

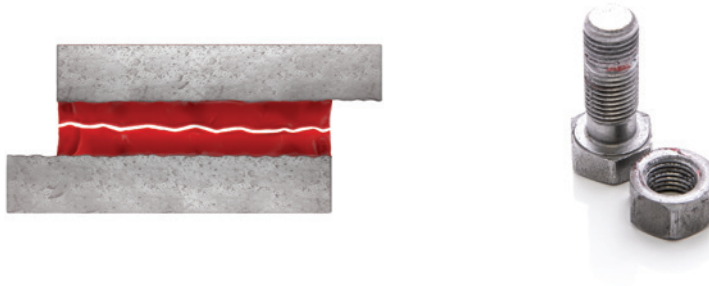

FIGURE 84
Adhesive failure.

Cohesive failure

Cohesive failure is when the fracture has occurred within the adhesive itself. In this failure mode, the adhesion strength was not exceeded. As shown in Figure 85, adhesive residue is visible on both the nut and the bolt.

FIGURE 85
Cohesive failure.



Substrate failure

Substrate failure is when the load exceeds the strength of one or the other of the bonded parts. This does not suggest failure of the adhesive but is nonetheless undesirable. For a threaded assembly, this may present itself as stripped threads, damaged screw head recesses and sheared screw heads during disassembly.

FIGURE 86
Substrate failure.



Root causes

8.2

There are three common root causes of unexpected failure:

Incomplete coverage of the bond area

Incomplete coverage of the bond area can be due to insufficient application of adhesive, or due to adhesive being pushed out of the adhesive bond joint, either by air displacement or pressure applied to the joint. Many products contain fluorescent additives that allow detection under UV light. This can be an important feature to aid in detecting the presence or traces of an adhesive.

Insufficient adhesion to the substrate

The second root cause can be observed when adhesive failure is observed on the parts. When adhesive fails on a substrate at a strength lower than expected, the root cause of the insufficient adhesion to the substrate can be due to incompatibility with the substrate or to contamination. If the contaminant and its source is unknown, analytical science techniques such as infrared spectroscopy or energy-dispersive X-ray spectroscopy (EDS) may be needed to identify it. This will help find the source so future contamination can be prevented.

Incomplete curing of adhesive

In failure mode analysis, cohesive failure tells us that the adhesive has successfully bonded to both surfaces. However, it is also possible that the adhesive has not achieved its full cohesive strength. In other words, it has partially cured. In order to achieve the expected strength within an assembly, it is important to make sure that the adhesive is completely cured. There are a variety of reasons why an adhesive would not achieve full cure. Adhesives in contact with some materials can experience interactions that will limit the curing reaction and result in insufficient cure. For example, when an anaerobic material is in contact with nitrites, a corrosion inhibitor found in lubricants, cleaners and protection fluids, the curing reaction can be inhibited. Ambient temperatures can also influence the curing rate of an adhesive. At cold temperatures, most curing reactions will typically slow down, which will result in a slower strength build up than observed at higher temperatures. Part-to-part variations in the dimensions of the bond gap between substrates can also impact the cure speed of the adhesive.

When troubleshooting finds the root cause of a failure, the solution to the issue is often easy or simple to implement.



Section 9

SHELF LIFE

How we maintain
product performance

During the development of each product, a thorough stability study is performed to ensure consistent product performance throughout its shelf life. Appearance, viscosity, cure speed and strength on a controlled test specimen are some of the quality specifications that a product must meet. Most threadlocker products can be stored at room temperature for two years. The adhesive is stabilized in the package by various means.

Packaging

Anaerobic adhesives remain liquid (stabilized) in the presence of oxygen. The anaerobic bottles are intentionally filled half-way so the oxygen in the empty space will prevent the threadlocker from curing. Additionally, the bottles are made from air permeable low-density polyethylene, ensuring the presence of sufficient oxygen to prevent curing.

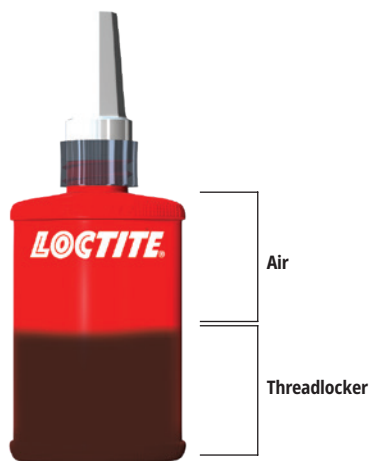

FIGURE 87
Illustration showing a half-filled bottle.

Additional stabilizers

The adhesive formulation also contains additives to stabilize prematurely generated free radicals and any metal ion contamination.



Section 10

CERTIFICATIONS AND STANDARDS

Independent testing
to ensure suitability.

Product certifying organizations

10.1

In some markets it is desirable and sometimes mandatory that independent laboratory testing be done to establish the suitability of a material for its intended use. The Underwriter's Laboratory (UL) and NSF International, originally the National Sanitary Foundation, are two organizations that provide certifications relevant to machinery adhesives.

The Underwriter's Laboratory (UL)

The UL's purpose is to evaluate materials, devices, products, equipment, construction methods and systems with respect to hazards that affect life and property. The UL's approvals do not extend to the products assembled with these materials. Separate approvals must be sought for assembled products. For instance, a gas meter assembled with an approved machinery adhesive needs separate approval even though the sealant is approved for the application.

NSF International (NSF)

The National Sanitation Foundation does not allow materials in potable water systems or food processors to have extractable chemicals or detectable taste or odor. Machinery adhesives are detectable after cure. However, individual mechanisms using machinery adhesives can be approved after appropriate cleaning and testing.

Test standards

10.2

Testing standards and performance specifications for machinery adhesives have been established by government agencies and industrial organizations in several countries. Henkel's machinery adhesives are tested according to internationally recognized standards from the International Standards Organization (ISO), United States Military Standards and ASTM International (formerly American Society for Testing and Materials).

International Standards Organization

The ISO is an independent, non-governmental international organization with a membership of many national standards bodies. The organization has standardized many test methods relevant to machinery adhesives, including ISO 10964, ISO 10123 and ISO 16047.

US Military Standards

Military standards MIL-S-22473 and MIL-S-46163 were written to establish the requirements and test standards for single-component machinery adhesives. They are intended to be a means of classifying the adhesives and do not address engineering design purposes. These military specifications have been inactivated for new designs, and ASTM D5363 is the intended replacement.

ASTM International

ASTM International is a voluntary standards developing organization and has standardized test methods relevant to machinery adhesives, including ASTM D5649, ASTM D4562 and ASTM D5648-01. ASTM D5363 is a specification that also aims to be a means of classifying anaerobic adhesives.



Section 11

APPENDIX

Contact

11.1

Find out how you can put our expertise to work for you. Visit henkel-adhesives.com, and select your region to find global technical support for your facility.

Chemical compatibility chart

11.2

LIQUIDS					
Abrasive lubricant	+	Alcohol	+	Aluminium potassium	+
Abrasive slurry	+	Allyl alcohol	+	Aluminium sulphate	+
Accumulator acid	10%	Amyl alcohol	+	Amine	+
Acetaldehyde	+	Butyl alcohol	+	Ammonia anhydride	-
Acetamide	+	Ethyl alcohol	+	Ammonium bisulphite	+
Acetate solvents	+	Hexyl alcohol	+	Ammonium borate	+
Acetic acid	10%	Isopropyl alcohol	+	Ammonium bromide	+
Acetic ether	+	Methyl alcohol	+	Ammonium carbonate	+
Acetone	+	Propyl alcohol	+	Ammonium chloride, sal ammoniac	+
Acetyl chloride	+	Alkaline solution (alkaline salt water)	+	Ammonium chromate	+
Acetyl salicylic acid	+	Alum	+	Ammonium copper formate	+
Acetylene (liquid)	+	Chromic alum	+	Ammonium formate	+
Acidic alum earth	+	Potash alum	+	Ammonium hyposulphite	+
Acrylic acid	+	Sodium alum	+	Ammonium iodide	+
Acrylonitrile	+	Alum earth	+	Ammonium molybdate	+
Activated carbon	+	Aluminium acetate	+	Ammonium oxalate	+
Activated silica	+	Aluminium bicarbonate	+	Ammonium persulphate	+
Active aluminium oxide	+	Aluminium bifluoride	+	Ammonium phosphate	+
Aftershave	+	Aluminium chloride	+	Ammonium picrate	+
Albumin	+	Aluminium hydroxide, alum earth	+	Ammonium silicofluoride	+

+ = Experience has shown that LOCTITE® products are resistant

° = Preliminary tests or resistance tests are recommended

% = LOCTITE® products are only resistant up to the given concentration

— = LOCTITE® products are not recommended, or may be used only after evaluation

Section 11: Appendix

LIQUIDS (CONTINUED)					
Ammonium sulphate	+	Barium hydroxide	10%	Bromine cyanide	+
Ammonium sulphide	+	Barium sulphate	+	Cadmium cyanide	+
Ammonium thiocyanate	+	Battery acid	10%	Bromine solution	°
Ammonium flouride	+	Bauxite (see aluminium)	+	Bronze cyanide	+
Amyl acetate	+	Beef extract	+	Butadiene	+
Amyl chloride	+	Beef stock	+	Buttermilk	+
Amylamine	+	Beer	+	Butyl acetate	+
Aniline	+	Beet juice or pulp	+	Butyl alcohol	+
Aniline dyes	+	Bentonite (emulsifying agent)	+	Butyl amine	+
Animal blood	+	Benzaldehyde, bitter almond oil	+	Butyl cellosolve	+
Animal fat	+	Benzene acid	+	Butyl chloride	+
Antibiotics	+	Benzene hexachloride	+	Butyl ether - dry	+
Antichlorine solution	+	Benzene hydrochloride	+	Butyl lactate	+
Antimony salt	+	Benzine	+	Butyraldehyde	+
Antimony trioxide	+	Benzol, benzene	+	Butyric acid	+
Antioxidant agents	+	Benzotriacide	+	Butyric acid	10%
Apple juice, apple wine	+	Beryllium hydrogen sulphate	+	Cadmium sulphate	+
Argon	+	Bicarbonate (liquid)	+	Cadmium Chloride	+
Armeen	+	Bilge medium	+	Plating solution	+
Arochlorine	+	Bitter almond oil	+	Calcium acetate	+
Aromatic gasoline	+	Bleached lime	+	Calcium bisulphate	+
Aromatic solvents	+	Bleaching bath	°	Calcium carbonate	+
Arsenic acid	+	Blood - animal	+	Calcium chlorate	+
Asbestos mass	+	Blood - human	+	Calcium chloride	+
Ash slurry	+	Blood substitute	+	Salt solution	+
Asphalt emulsion	+	Borax - liquid	+	Calcium citrate	+
Aureomycine	+	Bordeaux mixture	+	Calcium ferrocyanide	+
Aurous cyanide	+	Boric acid	+	Calcium formate	+
Aviation fuel	+	Brake fluid	+	Calcium hydroxide	+
Bacitracine	+	Brandy	+	Calcium hypochlorite	+
Bacterial media	+	Brine		Calcium lactate	+
Barium	+	Alkaline	+	Calcium nitrate	+
Barium acetate	+	Electrolytical	+	Calcium phosphate	+
Barium carbonate	+	for pickling	+	Calcium silicate	+
Barium chloride	+	Bromine	-	Calcium sulphamate	+

+ = Experience has shown that LOCTITE® products are resistant
 ° = Preliminary tests or resistance tests are recommended
 % = LOCTITE® products are only resistant up to the given concentration
 — = LOCTITE® products are not recommended, or may be used only after evaluation

LIQUIDS (CONTINUED)

Calcium sulphate	+	Chlorinated water	+	Cold brine	+
Calcium sulphite	+	Chlorinated wax	+	Common resin in alcohol	+
Camphor	+	Chlorine - dry	-	Concentrated nitric acid	-
Cane sugar (liquid)	+	Chlorine - liquid	-	Copper chloride	+
Cane sugar (refined)	+	Chlorine bleach	-	Copper chloride gasoline	+
Carbitol	+	Chlorine dioxide	°	Copper cyanide	+
Carbon disulphite	+	Chlorocarbon	+	Copper naphthenate	+
Carbon sugar	+	Chloroform	+	Copper pickle	+
Carbowax	+	Chloroform - dry	+	Copper plating (acidic)	+
Carboxyl methyl cellulose	+	Chlorophyll	+	Copper plating (alkaline)	+
Carnauba wax	+	Chlorosulphonic acid	-	Copper sulphate	+
Casein	+	Chocolate syrup	+	Coppering process (acid)	+
Casein water paint	+	Chrome bath	10%	Coppering process (caustic solution)	+
Cashew oil	+	Chromic acid	10%	Cottonseed oil	+
Castor oil	+	Chromic acid (50% cold)	°	Creosote	+
Caustic ammonia, ammonium hydroxide	°	Chromic acid (50% hot 40°-80°C)	-	Creosote oil	+
Celane	+	Chromic acid cleanser	10%	Creosotic acid	+
Cellosolve	+	Chromic sulphate	+	Cuprammonium format	+
Cellulose acetate	+	Chromium - liquid	10%	Cyanide solution	+
Cellulose pulp	+	Chromium acetate	+	Cyanuric chloride	+
Cellulose xanthate	+	Chromium chloride	+	Cyclohexane	+
Cement slurry	+	Citric acid solution (cold)	°	Cylinder oil	+
Cement, dry	+	Citric acid solution (hot)	°	DDT	+
Cement, liquid	+	Citrus juice	+	Detergent	+
Cereal oil	+	Citrus (concentrated)	+	Developer liquid	+
Cereal pulp	+	Clay	+	Dextran	+
Chalk	+	Coaltar	+	Dextrine, starch gum	+
Chemical pulp	+	Coating paint	+	Diacetone alcohol	+
Chestnut mordant	+	Cobalt, acidic	+	Diamyl amine	+
Chloramine	+	Cobaltous chloride	+	Diatom deposits, diatom earth	+
Chloric alcohol	+	Coconut oil	+	Diazo acetate	+
Chlorinated brine	+	Cod liver oil	+	Dibromic ethyl	+
Chlorinated kerosine	+	Coffee (concentrated)	+	Dibutyl phthalate	+
Chlorinated paper pulp	+	Coke dust	+	Dichlorethyl ether	+
Chlorinated solvents	+	Cola syrup	+	Dichlorophenol	+

Section 11: Appendix

LIQUIDS (CONTINUED)					
Dicyandiamide	+	Ethylene glycol	+	Furfural	+
Dielectric liquid	+	Excrement, excreta	+	Gallic acid	5%
Diethyl amine	+	Face cream	+	Gallium sulphate	+
Diethyl ether	+	Fatty acid amine	+	Gamma globuline	+
Diethyl glycol	+	Fatty acids	+	Gelatine (edible gelatine)	+
Diethyl sulphate	+	Fatty alcohol	+	Gelatine emulsion	+
Diglycol acid	+	Ferment	+	Glucol acid	+
Dimethyl formamide	+	Ferric chloride	+	Glucone acid	+
Dimethyl sulphine	+	Ferric floc	+	Glucose, starch sugar	+
Dioxan (dry)	+	Ferric sulphate (10%)	+	Glue emulsion	+
Dioxidene	+	Ferric sulphate		Glutamic acid	+
Dipentene pinene	+	Ferric sulphate (saturated)	+	Gluten, tirtizine	+
Diphenyl	+	Ferrous nitrate	+	Glycerine C.P.	
Dister lubricant	+	Fertilizer solution	+	- USP alkaline solution	+
Distilled water	+	Fibre bagasse	+	Glycine hypochloride	+
Distillery mash	+	Fine dust (dry)	+	Glycol acid	+
Distillery waste water	+	Flotation concentrates	+	Glycol amine	+
Drinking water	+	Fluorides	+	Glyoxal	+
Dyeing liquid	+	Fluorine gases and liquids	+	Glycocoll, glycine	+
Elaxal bath	+	Fluorolube	+	Gold monochloride	+
Emulsified oils	+	Flux	+	Grain pulp	+
Enamel	+	Foam generator	+	Grain sugar	+
Enamel frit	+	Foam latex	+	Granodine	+
Enzyme solution	+	Foamite	+	Grape juice	+
Epichloric hydrine	+	Formaldehyde (cold)	+	Grape pulp	+
Ergosterol solution	+	Formaldehyde (hot)	°	Grapefruit juice	+
Ethyl acetate, acetic ether	+	Formic acid (cold)	+	Grease lubrication	+
Ethyl alcohol, spirit of wine	+	Formic acid (hot)	°	Green potassium soap	+
Ethyl amine	+	Formic acid aldehyde (cold)	+	Grinding coolant	+
Ethyl cellosolve	+	Formic acid aldehyde (hot)	°	Ground siliceous earth	+
Ethyl format	+	Freon	(see gases)	GRS latex	+
Ethyl gasoline	+	Fruit juices	+	Hair tonic	+
Ethyl silicate	+	Fuel oil	+	Halo wax	+
Ethylene diamine	+	Fuming nitric acid	-	Halogen tin plating	+
Ethylene dichloride	+	Fuming sulphuric acid	-	Halon solution	+

+ = Experience has shown that LOCTITE® products are resistant
 ° = Preliminary tests or resistance tests are recommended
 % = LOCTITE® products are only resistant up to the given concentration
 — = LOCTITE® products are not recommended, or may be used only after evaluation

LIQUIDS (CONTINUED)					
Heptane	+	Iron ore taconite	+	Liver extract	+
Herb juice	+	Iron vitriol	+	LOX (liquid O2)	-
Hexachlorobenzene	+	Isobutyl alcohol	+	Magnesite	+
Hexadiene	+	Isobutyraldehyde	+	Magnesium bisulphate	+
Hexane	+	Isocyanate resin	+	Magnesium carbonate	+
Hexaphosphate	+	Isooctane	+	Magnesium chloride	+
Hexyl alcohol	+	Isopropyl acetate	+	Magnesium hydroxide	+
HtH	+	Isopropyl alcohol	+	Magnesium magma	+
Hydrazine	+	Isopropyl ether	+	Magnesium sulphate	+
Hydrazine hydrate	+	Itaconic acid	+	Maize kernels	+
Hydrochloric acid	°	Jet propulsion fuel	+	Maize oil	+
Hydrocyanic acid	10%	Kaolin	+	Maize syrup	+
Hydrofluoric acid	-	Kelp sludge	+	Maize water	+
Hydrogen	+	Kernel oil	+	Maleic acid	+
Hydrogen bromide	10%	Kerosine	+	Maleic anhydride	+
Hydrogen fluoride gas	°	Ketone	+	Malt residuum	+
Hydrogen peroxide	+	Lactic acid	+	Malt syrup	+
Hydrogen peroxide concentrate	°	Lactose	+	Maltose, malt sugar	+
Hydroponic solution	+	Lapping abrasive	+	Manganese chloride	+
Hydroquinone	+	Lard	+	Manganese sulphate	+
Hydrosilicofluoric acid	+	Latex rubber	+	Mannite solution	+
Hydroxypropionic acid	+	Latex, natural	+	Mayonnaise	+
Hypochloride	+	Latex, synthetic	+	Melamine resin	+
Ice cream	+	Laundry bleach	+	Melted sugar	+
Infusorial earth	+	Laundry blue	+	Menthol	+
Ink	+	Laundry water	+	Mercaptan, thio-alcohol	+
Insecticide	+	Lead arsenate	+	Mercuric chloride	+
Iodine benzene	+	Lead fluoride	+	Mercuric nitrate	+
Iodine in alcohol	+	Lead oxide	+	Mercury	+
Iodine solutions	+	Lead sulphate	+	Mercury (dry)	+
Iodine		Lecithine	+	Methane	+
- potassium iodide	+	Lemon juice	+	Methanol, methyl alcohol	+
Ion exchange liquid	+	Lignine extract	+	Methyl acetate	+
Iron ore oxide	+	Linseed oil	+	Methyl bromide	+
Iron ore phytate	+	Lithium chloride	+	Methyl carbitol	+

Section 11: Appendix

LIQUIDS (CONTINUED)					
Methyl cellosolve	+	Nitrating acid	-	Vegetable oils	+
Methyl chloride (not adhesive)	°	Nitric acid	10%	Oleic acid cold	+
Methyl ethyl ketone	+	Nitric acid 20%	°	Oleic acid hot	+
Methyl isobutyl ketone, isopropyl acetone	+	Nitric anhydride	-	Orange juice	+
Methyl lactate	+	Nitroacrylic sulphonic acid	+	Ore pulp	+
Methyl orange	+	Nitrobenzene, dry	+	organic dyes	+
Methylamine	+	Nitrocellulose	+	Oxalic acid	+
Methylene dichloride (not adhesive)	+	Nitrofurane	+	Ozone, liquid	-
Milk	+	Nitroguanidine	+	Paint (for vehicles)	+
Milk chocolate	+	Nitrohydrochloric acid	-	Paint (linseed based)	+
Milk of magnesium	+	Nitroparaffin, dry	+	Paint (water-soluble)	+
Mineral oil, white	+	Nitrosyl chloride	+	Palm oil	+
Molasses, edible	+	Norite carbon	+	Palmitic acid	+
Molasses, raw	+	Nuchar	+	Paper mill waste	+
Molten asphalt	+	Nutrient fat	+	Paper pulp	
Molten ceramic	+	Oakite	-	Bleached	+
Molten paraffin	+	Oils		Chlorinated	+
Molten phosphor	+	Animal oils	+	Washed and bleached	+
Monochloroacetic acid	+	Castor oil	+	With amum	+
Monochlorobenzene	+	Coconut oil	+	With dye	+
Monochrome solution (alk.)	+	Cod liver oil	+	Paper rags	+
Morphalin	+	Creosotic oil	+	Paradichlorobenzene	+
Mustard	+	Emulsified oils	+	Paraffin oil kerosine	+
Naphtha, paraffin, rock oil	+	Fish oil	+	Paraformaldehyde	+
Naphthalene	+	Fuel oil	+	Peanut oil	+
Neoprene emulsion	+	Grain oil	+	Pectine	+
Neoprene latex	+	Linseed oil	+	Penicillin	+
Niacin	10%	Lubricating oil	+	Penta-erythrite solution	+
Nickel	+	Mineral oil	+	Pentachloroethane	+
Nickel acetate	+	Olive oil	+	Perchloric acid	10%
Nickel ammonium sulphate	+	Palm oil	+	Perchloromethyl mercaptan	+
Nickel fluoborate	+	Peanut oil	+	Perfume	+
Nickel plating	+	Soluble oils	+	Permanganic acid	-
Nickel sulphate	+	Soybean oil (raw)	+	Peroxide bleach	+
Nitrane solution	+	Tall oil	+	Persulphuric acid	10%

+ = Experience has shown that LOCTITE® products are resistant
 ° = Preliminary tests or resistance tests are recommended
 % = LOCTITE® products are only resistant up to the given concentration
 — = LOCTITE® products are not recommended, or may be used only after evaluation

LIQUIDS (CONTINUED)					
Petroleum ether	+	Cobalt (acidic)	+	Potassium xanthate	+
Petroleum spirit alkaline solution	+	Copper (acidic, caustic)	+	Pressboard waste	+
Petroleum spirit cuprous chloride	+	Gold cyanide	+	Propionic acid	+
Petroleum spirit acid bath	+	Iron (acidic)	+	Propyl alcohol	+
Petroleum spirit, acidic	+	Lead fluoride	+	Propyl bromide	+
Petroleum spirit, white	+	Nickel	+	Proteins	+
Pharmaceutical substances	+	Platinum	+	Pyranol	+
Phenol	+	Silver cyanide	+	Pyridine	+
Phenolic cement	+	Tin (acidic)	+	Pyrogallic acid	+
Phenolic resins	+	Zinc (acidic)	+	Pyrole	+
Phenolsulphonic acid	+	Zinc (caustic)	+	Pyromellitic acid	+
Phenylbetanaphthyl	°	Polio vaccine	+	Quebracho tannin	+
Phenylic acid	10%	Polyacrylnitrile sludge	+	Quinone	+
Phloroglucinol	+	Polyphosphoric acid	10%	Rayon viscose	+
Phosphate ester	+	Polysulphide liqueur	+	Riboflavin	+
Phosphor sand	+	Polyvinyl chloride slurry	+	River water	+
Phosphoric acid		Porcelain frit	+	Roccal	+
85% hot	-	Potash, potassium carbonate	+	Rubber paste	+
85% cold	°	Potassium acetate	+	Safrol	+
50% hot	°	Potassium alum	+	Sal ammoniac	+
50% cold	°	Potassium bichromate	+	Salad dressing	+
10% hot	°	Potassium bromide	+	Salad oil	+
10% cold	+	Potassium carbonate	+	Salicylic acid	+
Phosphotungstic acid	+	Potassium chloride solution	+	Saliferous soil physiological	+
Phthalic acid	+	Potassium chromate	+	Salt water	+
Picric acid solution	+	Potassium cyanide solution	+	Sebum, tallow	+
Pine oil	+	Potassium hydroxide	-	Selenium chloride	+
Pineapple juice	+	Potassium iodide	+	Sewage, excreta	+
Pit water	+	Potassium nitrate	+	Shellac	+
Plasma thinners	+	Potassium permanganate	+	Shower water	+
Plating substances:		Potassium perchlorate	+	Silica gel	+
Brass cyanide	+	Potassium persulphate	+	Silicon liquids	+
Bromine	+	Potassium phosphate	+	Silicon tetrachloride	+
Cadmium cyanide	+	Potassium silicate	+	Silver cyanide	+
Bronze cyanide	+	Potassium sulphate, sulphuric potassium	+	Silver iodide	+

Section 11: Appendix

LIQUIDS (CONTINUED)					
Silver nitrate	+	Sodium hypochloride	+	Sulphonyl chloride	+
Slaked lime	+	Sodium lignosulphonate	+	Sulphur slurry solution in carbon bisulphide	+
Slate (up to 400 mesh)	+	Sodium metasilicate	+	Sulphuric acid	°
Sloe gin	+	Sodium monophosphate	+	0 - 7%	°
Soapsuds (stearates)	+	Sodium nitrate	+	7 - 40%	°
Soda pulp	+	Sodium nitrite (nitrate)	+	40 - 75%	°
Sodium aluminate	+	Sodium perborate	+	75 - 95%	-
Sodium acetate	+	Sodium peroxide	-	95 - 100%	-
Sodium benzene sulphonate	+	Sodium persulphate	+	Sulphuric iron oxide (10%)	+
Sodium bicarbonate	+	Sodium potassium chloride	+	Sulphurized oils	+
Sodium bichromate	+	Sodium sulphide	+	Synthetic latex	+
Sodium bisulphite	+	Sodium stannate		Syrup	+
Sodium bisulphite	+	Sodium (preparing salt)	+	Taconite	+
Sodium bromide	+	Sodium triphosphate	+	Tall oil	+
Sodium carbonate	+	Sodium xanthate	+	Tamine	+
Sodium chlorite	+	Solvent naphtha	+	Tannin, tannic acid (cold)	°
Sodium chlorate	+	Sorbic acid	+	Tartaric acid, dioxide succinic acid	+
Sodium chloride	+	Sorbit	+	Tergitole	+
Sodium cyanide	+	Soybean oil	+	Tetrachloroethylene (dry)	+
Sodium dithionite	+	Spirit of wine	+	Tetraethyl lead	+
Sodium ferrocyanide	+	Starch	+	Tetrahydrofurane	+
Sodium fluoride	+	Starch basis	+	Tetranitromethane	+
Sodium format	+	Stearic acid	+	Textile dye	+
Sodium fluat	+	Sterilizing steam	+	Textile finishing oils	+
Sodium glutamate	+	Streptomycine pulp	+	Textile printing oil	+
Sodium hydrosulphide	+	Styrene	+	Thiocarbamide	+
Sodium hydrosulphite	+	Styrene-butadienne latex	+	Thioglycolic acid	+
Sodium hydrochloride	+	Sulpha-sulpho- anhydride	+	Thionyl chloride	+
Sodium Hydroxide		Sulphamic acid	+	Thiophosphoryl chloride	+
20% cold	+	Sulphate	+	Thorium nitrate	+
20% hot	°	Sulphate hiazole	+	Thymol, thyme camphor	+
50% cold	°	Sulphite liquor	+	Tin (alk.)	+
50% hot	-	Sulphocyanic acid	+	Tin solder	+
70% cold	°	Sulphones	+	Titanium oxide mass	+
70% hot	-	Sulphonic acids	10%	Titanium oxide sulphate	+

+ = Experience has shown that LOCTITE® products are resistant
 ° = Preliminary tests or resistance tests are recommended
 % = LOCTITE® products are only resistant up to the given concentration
 — = LOCTITE® products are not recommended, or may be used only after evaluation

LIQUIDS (CONTINUED)					
Titanium tetrachloride	+	Vanadium pentoxide	+	Soft	+
Tobacco wash solution	+	Vanilla extract	+	Sterilized	+
Toluene	+	Varnish	+	Wax	+
Toluol sulphonic acid	°	Varnish thinners	+	Weisberg sulphate plating	+
Toluol, methylbenzene	+	Varsole	+	Wheat adhesive	+
Tomato juice	+	Vaseline	+	Whisky	+
Tomato ketchup	+	Versen	+	Whisky residuum	+
Toothpaste	+	Vinegar	+	White spirit	+
Transile oil	+	Vinyl acetate	+	Wine	+
Trichloroacetic acid	+	Vinyl chloride latex emulsion	+	Wort, malt extract	+
Trichloroethane	+	Vinylha	+	Xylene, dimethyl-benzene	+
Trichloroethylene	+	Vitamins in oil	+	Zeolite water	+
Triethanolamin	+	Washing soda	+	Zinc alk. (cyanide)	+
Triglycol	+	Water		Zinc bromide	+
Triorthocresylphosphate	+	Under pH7*	+	Zinc chloride	+
Trioxane	+	pH7 to pH8	+	Zinc cyanide (alk.)	+
Tungstic acid anhydride	+	(Alk.) over pH8*	+	Zinc galvanizing	+
Turpentine	+	Boiling	°	Zinc oxide	+
Turpentine oil	+	Carbonated	+	Zinc oxide in water	+
Ucon lubricating oil	+	Chlorinated		Zinc solder	+
Udylithe solution	+	Up to 100 ppm	+	Zinc sulphate	+
Undecylene acid	+	Demineralized	+	Zincolate	+
Uranium salts	+	Desalinated	+	Zircon nitrate	+
Uranyl nitrate	+	Distilled	+	Zircon sulphate	+
Uranyl sulphate	+	Filtered	+		
Vacuum oil	+	Sandy	+		

Section 11: Appendix

GASES					
Acetylene	+	Cyanogen chloride	+	Isobutane	+
Acidic vapours	+	Cyanogen gas	+	Methane, fire damp	+
Alk. vapour	+	Ethane	+	Methyl chloride, chloromethane	+
Amine	+	Ether	+	Natural gas (dry)	+
Ammonia, sal ammoniac	+	Ethylene	+	Nitrogen	+
Butadiene gas (liquid)	+	Ethylene oxide	+	Oxygen	-
Butylene gas (liquid)	+	Factory gases	+	Oxygen 150 psi	-
Byproduct gas (liquid)	+	Freon (11-12-21-22)	°	Ozone	-
Carbon bisulphide gas	+	Furnace gas (cold)	+	Propane	+
Carbon dioxide	+	Furnace gas (hot)	°	Propylene	+
Carbon monoxide	+	Generator gas 50 psi	+	Sulphur dioxide	+
Chloride dry	+	Helium	+	Sulphur dioxide (dry)	+
Chlorine gas (dry)	-	Hydrocyanic acid	10%	Sulphur trioxide (dry)	+
Chlorine gas (liquid)	-	Hydrogen chloride	+	Sulphur trioxide gas	-
Coke oven gas (cold)	+	Hydrogen (cold)	+	Sulphuric acid vapour	+
Coke oven gas (hot)	°	Hydrogen sulphide wet and dry	+	Titanium	+

+ = Experience has shown that LOCTITE® products are resistant

° = Preliminary tests or resistance tests are recommended

% = LOCTITE® products are only resistant up to the given concentration

— = LOCTITE® products are not recommended, or may be used only after evaluation

COMPATIBILITY OF COMMERCIAL PLASTICS WITH LOCTITE® ANAEROBIC* PRODUCTS					
Acrylonitrile-Butadiene-Styrene (ABS)	-	Phenolic	+	Polyimide (PI)	+
Acetal (POM)	+	Polyamide (Nylon)	+	Polymethylpentene (PMP)	+
Acrylic (PMMA)	-	Polybutylene terephthalate (PBT)	+	Polyphenylene oxide (PPO)	-
Acrylic-Styrene-Acrylonitrile (ASA)	-	Polycarbonate (PC)	-	Polyphenylene sulfide (PPS)	-
Allylic Ester (DAP, DAIP)	+	Polyester, Thermoset	+	Polypropylene (PP)	+
Cellulosic (CAP)	-	Polyetheretherketone (PEEK)	-	Polystyrene (PS)	-
Epoxy	+	Polyetherimide (PEI)	+	Polyurethane (PU)	+
Fluoropolymers (PTFE, FEP, PFA, ETFE)	+	Polyethersulfone (PES)	-	Polyvinyl chloride (PVC)	-
Ionomer	-	Polyethylene (PE)	+	Styrene-Acrylonitrile (SAN)	-
Liquid Crystal Polymer (LCP)	+	Polyethylene terephthalate (PET)	+		

+ = Often suitable, test to verify compatibility.

- = Often not suitable, sealant adhesive may attack plastic.

Unit conversion table (imperial/metric)

11.3

DIMENSIONS	LENGTH	SI SYMBOL	MULTIPLICITY	ENGLISH OR C.G.S	MULTIPLICITY	TO GET SI OR C.G.S
Length	metre	m	x 3.28 =	feet	x 0.305	= metre
	millimetre	mm	x 0.039 =	inch	x 25.4	= millimetre
Force	newton (kg•m/s ²)	n	x 0.225 =	pound	x 4.448	= newton
	kilogram	kgf	x 2.204 =	pound (lbf avior)	x 0.454	= kilogram
	newton	N	x 3.597 =	pound (lbf avior)	x 0.287	= newton
Mass	kilogram	kg	x 2.204 =	pound (avior)	x 0.454	= kilogram
Pressure stress	megapascal	Mpa (MN/m ²)	x 145 =	lb-in ²	x 0.00689	= megapascal
		kgf/cm ²	x 14.23 =	lb-in ²	x 0.0702	= kgf/cm ²
		daNcm ²	x 14.5 =	lb-in ²	x 0.00689	= decanewton/cm ²
Area	sq.metre	m ²	x 10.8 =	ft ²	x 0.93	= megapascal
	sq.centimetre ²	cm ²	x 0.155 =	in ²	x 6.45	= cm ²
Torque	newton metre	N.m	x 0.738 =	lb-ft	x 1.356	= newton metre
	newton metre	N.m	x 8.85 =	lb-in	x 0.113	= newton metre
		kgf.cm	x 7.23 =	lb-ft	x 0.138	= kgf/m
		kgf.cm	x 0.87 =	in-lb	x 1.15	= kgf.cm
Volume	cubic metre	m ³	x 0.001 =	litre	x 1000	= m ³
	litre (dm ³) or m x 10 ⁻³	L	x 1.057 =	quart (liquid)	x 0.946	= litre
	litre (dm ³)	L	x 33.81 =	ounce (us)	x 0.02957	= litre
	litre (dm ³)	L	x 61.02 =	in ³	x 0.01639	= litre
	cc (cm ³)	cc	x 0.06102 =	in ³	x 16.39	= cc
Angle	Radian	rad	x 57.30 =	degree	x 0.01745	= radian
Viscosity dynamic kinematic	pascal.sec	Pa.s	x 1000 =	Centipoise	x 0.001 =	= Pa.s
	sq.Metre/sec	m ² /s	x 10000 =	Stokes	x 0.0001 =	= m ² /s

11.4

Volume calculation

METRIC THREAD	IMPERIAL THREAD	VOLUME OF PRODDUCT PER COMPONENT*	NUMBER OF COMPONENTS PER BOTTLE		
		(ML)	10 ml	50 ml	250 ml
M4	#8	0.006	1,600	8,000	40,000
M6	1/4"	0.018	500	2,500	12,500
M10	3/8"	0.060	160	800	4,000
M20	3/4"	0.454	20	100	500
M30	1-1/8"	0.995	10	50	250

* Assumes 0.1 mm clearance (M3–M10) and 0.2 mm clearance (M20 and M30), with 20% over application.

11.5

Technical information: Standard test methods for threadlocker testing

11.5.1

ISO 10964 adhesives

Determination the torque strength of anaerobic adhesives on threaded fasteners: This ISO method is the most referenced method on a threadlocker technical data sheet. This method is used to determine the following cured properties of threadlockers:

- Break-away torque
- Break-loose torque
- Prevailing torque
- Heat aging
- Hot strength
- Chemical resistance
- Environmental resistance

ISO 10123 adhesives

Determining the shear strength of anaerobic adhesives using pin-and-collar specimens: Nuts and bolts can have dimensional variations in their threads. Those threads can also be damaged easily, leading to variations in the break-away and/or break-loose torque results. Hence, compressive shear strength is also evaluated to gain a more accurate characterization of a threadlocker product. Additionally, the pin-and-collar substrates used in this test have high tolerances and provide more reproducible results. This method is used to measure the following cured properties of threadlockers:

- Compressive shear strength
- Cure speed vs bond gap

Summary of ISO 10123

The standard specimen is comprised of a 12.65–12.675 mm (0.498–0.499") diameter pin and a slip collar with a 12.7–12.725 mm (0.500–0.501") inside diameter by 11.05–11.15 mm (0.435–0.439") wide. Both components are finished to 0.8–1.6 μm Ra (32–64 μin Ra) with 0.025–0.075 mm (0.001–0.003") diametral clearance between the pin and collar. The specimens are degreased before testing.

The shear strength is calculated as follows:

$$\text{shear strength} = \frac{\text{load at failure}}{\text{bond area}}$$

where $\text{bond area} = \pi \times \text{pin diameter} \times \text{collar width}$



FIGURE 88
Pin and collar specimen.

11.5.3

ISO 16047 assembly

The conditions for carrying out torque/clamp force tests on threaded fasteners and related parts are specified in ISO 16047. It is applicable, basically, to bolts, screws, studs and nuts made of carbon steel and alloy steel, whose mechanical properties are specified in ISO 898-1, ISO 898-2 or ISO 898-6 and have ISO metric threads with thread sizes M3 to M39. This method is used to measure the following uncured properties of a threaded assembly with and without threadlocker or other thread lubricants in order to provide a more accurate relationship between torque and tension:

- Torque coefficient (k-factor), K
- Coefficient of thread friction, μ_{th}
- Coefficient of bearing friction, μ_b
- Coefficient of total friction, μ_{tot}

Henkel recommends that you test all new adhesive applications under simulated or actual end use conditions to ensure the adhesive meets or exceeds all required product specifications. Since assembly conditions may be critical to adhesive performance, it is also recommended that testing be performed on specimens assembled under simulated or actual production conditions.

That's all folks!

Thanks for sticking around to the end.

LOCTITE^X

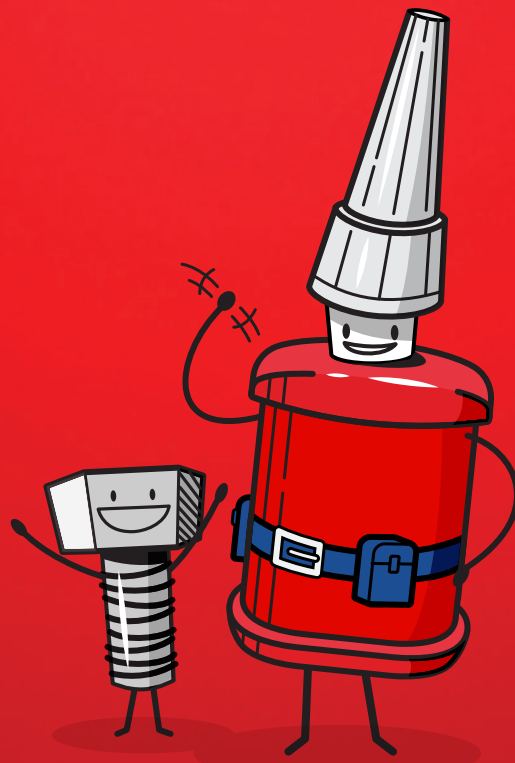

Visit LOCTITE®XPLORE and get certified!

The journey doesn't have to end here! There's a whole e-learning platform waiting for you at loctitexplore.com with more opportunities to upskill your knowledge. Sign up or log in today to keep the learning going!



Scan the code to register now:



Having trouble with our QR code? Visit loctitexplore.com on your mobile device.

Then flip back through this book and look for this visual to show you that you can have an enhanced learning experience on LOCTITE®XPLORE.

It's that easy!



Section 12

BIBLIOGRAPHY

“Adhesive.” Wikipedia. Wikimedia Foundation, August 30, 2020.
<https://en.wikipedia.org/wiki/Adhesive>.

Bickford, John H. *Introduction to the Design and Behavior of Bolted Joints: Non-Gasketed Joints*. Boca Raton, FL, FL: CRC Press, 2008.

Birkett, David, and David Condron. “Anaerobic Adhesives.” *Henkel Adhesive Technologies*, 2017. Birkett, David and David Condron. *Anaerobic Adhesives*. Whitestown, Dublin 24, Ireland: Henkel Adhesive Technologies, Technology Centre Europe, 2017.

Degano, Ilaria, et al. *Hafting of Middle Paleolithic tools in Latium (central Italy): New data from Fossellone and Sant’Agostino caves*. Milano, Italy: Plos One, 2019. <https://doi.org/10.1371/journal.pone.0213473>.

European Committee for Standardization. “Adhesives - Terms and Definitions.” Adhesives: European Committee for Standardization, 2015.

Feeney, Michael. *Reliable Threaded Fastener Assemblies: Torque-Tension Relationship- K Factor*. Henkel Corporation, 2015.

Grant, Ellsworth S. *Drop by Drop: the LOCTITE® Story*. The LOCTITE® Corporation, 1983.

-
- Haviland, Girard S. *Machinery Adhesives for Locking, Retaining, and Sealing*. New York City, NY: Dekker, 1986.
- Henkel. History, 2020, www.henkel.com/company/milestones-and-achievements/history.
- Kerley, James J. *An Application of Retrodution to Analyzing and Testing the Backing off of Nuts and Bolts during Dynamic Loading*. Greenbelt, MD: Goddard Space Flight Center, 1987.
- Junker, Gerhard H. "New Criteria for Self-Loosening of Fasteners Under Vibration." *SAE Technical Paper Series*, 1969. <https://doi.org/10.4271/690055>.
- "LOCTITE®." Wikipedia. Wikimedia Foundation, January 2, 2020. <https://en.wikipedia.org/wiki/Loctite>.
- Manufacturing Reliability Advanced Training Manual. 5th ed.* Rocky Hill, CT: Henkel Corporation, 2005.
- Olson, Tyler. *Preload Influences on Fastener Fatigue Life*. Winona, MN: Fastener Technology International, 2015.
- Pizzi, A., and K. L. Mittal. *Handbook of Adhesive Technology*. New York City, NY: M. Dekker, 2003.
- "Shear Thinning." Wikipedia. Wikimedia Foundation, July 7, 2020. https://en.wikipedia.org/wiki/Shear_thinning.
- Speck, James A. *Mechanical Fastening, Joining, and Assembly*. Boca Raton, FL: Taylor & Francis, 2014.
- "Thread-Locking Fluid." Wikipedia. Wikimedia Foundation, January 1, 2020. https://en.wikipedia.org/wiki/Thread-locking_fluid.
- Woo, Chulsoo. "Functional Adhesive Trend for Assembly Industry." *Henkel Corporation*, 2018.
- Woo, Chulsoo. "Liquid Thread Locking Solution for Assembly Industry." *Henkel Corporation*, 2019.
- Woo, Chulsoo. "Liquid Thread Locking Solution for Machinery Assembly Industry." *Adhesives and Adhesive Joints in Industry Applications*, 2019. <https://doi.org/10.5772/intechopen.85090>.

LOCTITE[®]