

LOCTITE®

LEAK- FREE FLANGES

A LOCTITE
DESIGN GUIDE

Henkel

CONTENTS

1. Introduction	3
2. Definitions	4
3. General Design Considerations	5
3.1 General Guidelines	5
3.2 Basic Design of Housings	6
3.3 Flange Rigidity	6
3.4 Bolt Positioning and Spacing	9
3.5 Bolt Grade and Length	12
3.6 Flange Design Verification	13
3.7 Surface Finish	14
4. FIPG Application Areas, Advantages Over Solid Gaskets	17
5. Design Recommendations for Anaerobic FIPGs	20
6. Design Recommendations for RTV Elastomers	22
6.1 Basic Flange Design	23
6.2 Alternative Design	26
7. Product Dispensing and Assembly	32
7.1 Cleaning	32
7.2 Dispensing	32
7.3 Assembly	35
8. Service and Repair	36
8.1 Disassembly	36
8.2 Cleaning	38
8.3 Application and Assembly	39
9. Scope and Limitations	40
10. Abbreviations	41
11. Bibliography	42
11.1 Release	43
11.2 Authors	43

1. INTRODUCTION

Lightweight designs and the constant increase of capacity lead to highly stressed components and potential deformations at critical areas such as joints, sealing flanges, bolting elements, and attached housing areas. Also, the need for better environmental resistance with zero-leak requirements for flanged joints increases the difficulty for the designer.



To ensure that zero-leak requirements are met, it is essential that the joint be designed in accordance with gasket-specific guidelines. It is the intention of this guide to provide general design considerations that are gasket-type independent as well as specific guidelines for liquid gaskets, such as formed-in-place gaskets with anaerobic cure and room temperature vulcanizing RTV Elastomers.

The design guidelines are based on results obtained by dynamic fatigue tests, the analysis of existing gasketed joints, experience, and the results of analytical and numerical calculations within Henkel^{2 to 28} and independent institutes¹. The general design considerations described in Section 3 summarize the gained knowledge of three projects at the University of Stuttgart sponsored by the Forschungsvereinigung Antriebstechnik, in which Henkel is an active partner.

2. DEFINITIONS

A gasket is a material positioned between two flanges which are held together by fasteners. Gaskets prevent leaking of fluids or gases by completely filling the space between the surfaces of the flanges. It is necessary for the seal to remain intact and leak-free for a prolonged time. The gasket must be resistant to the medium being sealed and able to withstand the application temperature, pressure, and micromovements caused by vibration as well as thermal expansion/contraction.

Flange Seals are classified as static or dynamic, depending on whether the sealed parts move relative to each other. A rotating shaft in a housing is an example of a typical dynamic system. While flanges are classified as static systems, they encounter small micromovements because of vibration, temperature changes, pressure changes, shock, impact or transmitting loads. The static gaskets or seals are categorized as shown in Figure 1.

FIGURE 1:

GASKET TYPES

FIP (Formed-In-Place) Gaskets are formed by the application of a bead, roll coated film or by screen print of liquid elastomer or anaerobic sealant, which is then assembled in the uncured state. On assembly, the sealant is smeared between the flanges and forced into surface imperfections to provide total contact between the two faces, and cures to form a durable seal.

CIP (Cured-In-Place)

Gaskets are formed by the application of a bead of elastomer to one flange that is cured before the flanges are assembled. The gasket is then compressed by the mating flange to form the seal.

IIP (Injected-In-Place) Gaskets are liquid gaskets that are injected, after the assembly of the joint, into a groove between the two flange faces and then cured.

MIP (Molded-In-Place) Gaskets are molded directly onto one of the mating parts, usually into a groove.

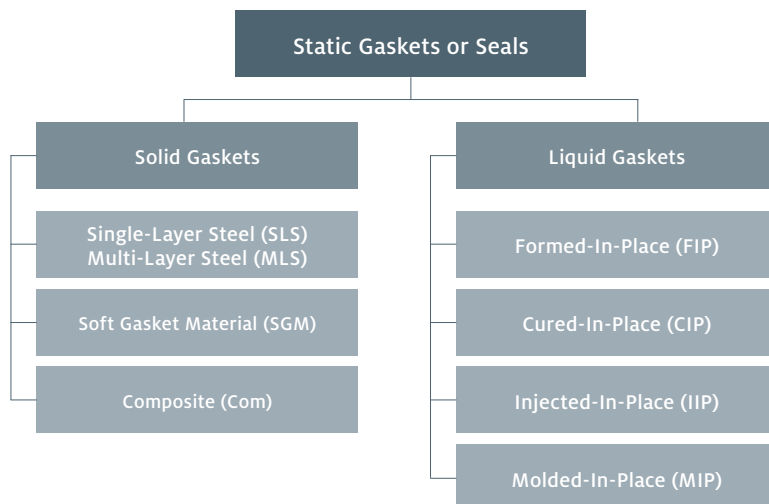

3. GENERAL DESIGN CONSIDERATIONS

3.1. GENERAL GUIDELINES¹

For the design of highly stressed gasketed joints, the following basic rules should be followed:

FLANGE PRESSURE DISTRIBUTION

It is necessary to achieve uniform flange pressure distribution within the permissible limits – which include the critical minimum sealing stress of the gasket and the admissible compressive strength of the flange material and the gasket.

OPERATING LOAD OF THE GASKETED JOINT

The gasketed joint has to be as rigid as possible in order to minimize deformations and relative movements.

While following the above-mentioned requirements, it is essential to follow the rules explained below for the design of joints independent of the sealing material:

RIGIDITY OF SEALING FLANGES

The rigidity of the sealing flange is indicated by the pressure distribution in the seal joint. Select the amount of rigidity correctly, so that the critical sealing stress of the gasket is reached in all flange areas.

BOLT PRELOAD

In order to minimize the loss of initial bolt load due to the relaxation of the gasket, it is necessary to ensure sufficient compliance of the flanges and the bolts (preload reserves).

CONSIDER DIFFERENT THERMAL EXPANSIONS

Due to different thermal expansions of aluminum housings with steel bolts, a cold environment can cause greater contraction of the aluminum flange and unload both the flange and the gasket. The minimum flange pressure required for a leak-free joint might then be compromised. High temperatures have the opposite effect, increasing the bolt and gasket load. In this case, the yield strength of the bolt and the compressive strength of the flange and the gasket are the limiting factors. Bolts and housings should have the same thermal expansion coefficient, if possible.

STRESS AND STRAIN OF THE GASKETED JOINT CAUSED BY EXTERNAL FORCES

In cases where the entire housing acts as a structure, the gasket joint should be as far as possible from the location where the forces feed into the housing.

3. GENERAL DESIGN CONSIDERATIONS

COMPRESSIVE STRESS DISTRIBUTION IN THE SEAL FLANGES

For optimum distribution of the bolt clamping load along the flange to the mid-point between the bolts, the bearing area of the bolt head should be as far away from the sealing area as possible. If the sealing area is in the middle of the effective bolt length (see Figure 7), the adjusting compressive stress distribution in the housing is optimized. The theoretical straight connection lines between bolts (see Figures 4 and 5) should not deviate significantly from the centerline of the gasket to allow a uniform compressive stress distribution within the whole flange width.

ADJUSTING THE FLANGE WIDTH TO THE COMPRESSIVE STRESS DISTRIBUTION

The bearing surface of the joint should be enlarged in the area of the bolt and reduced at midpoint between the bolts in order to obtain a more uniform compressive stress distribution in the seal joint.

3.2 BASIC DESIGN OF HOUSINGS¹

To develop a suitable sealing concept for the housing, the following basic rules for the design are recommended:

- Create small, spherical housing openings
- Use same materials for the seal flanges
- Try to achieve uniform temperature distribution

3.3 FLANGE RIGIDITY¹

The operational safety of a gasketed joint can be strongly influenced by varying the flange rigidity. The compressive stress distribution in the seal gap and in the flange between the bolt head and the seal gap indicates the rigidity of the joint. Figure 2 shows three possible variations of flange design and their influence on the component rigidity.

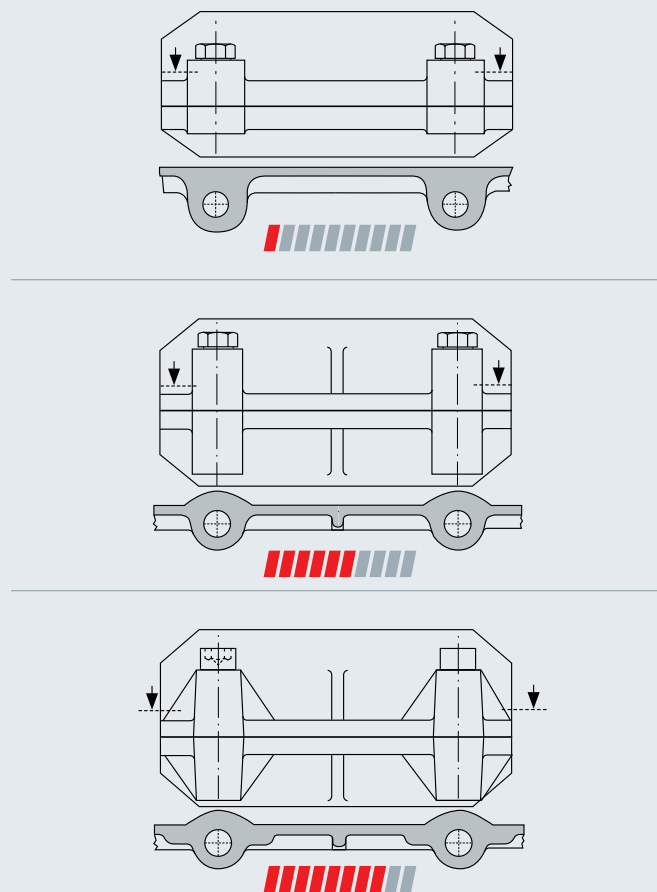

FIGURE 2

EVALUATION OF THE FLANGE DESIGN IN REGARD TO THE COMPRESSIVE STRESS DISTRIBUTION (QUALITATIVE), STIFFENING RIBS, BOSSES AT BOLT LOCATION - BEST SOLUTION BOTTOM ONE.¹

3. GENERAL DESIGN CONSIDERATIONS

As flange rigidity decreases, the more complicated it becomes to obtain the required minimum surface pressure at mid-point between two bolts. Figure 3 is based on external research work¹ and illustrates the influence of flange rigidity on the use of static gasket types. Soft gasket material and non-curing liquid gaskets are only suitable for flanges with adequate bending rigidity. If the minimum bending rigidity value is reached at the flanges, a change to anaerobic formed-in-place gaskets or embossed single-layer or multi-layer steel gaskets is required. The range of application for anaerobic formed-in-place gaskets is even wider, covering the whole range of very rigid flanges to flanges with medium rigidity.

Internal research work^{2,13} has shown that in cases where the required minimum surface pressure for anaerobics is not achieved or in cases of flexible flanges, like metal sheet parts, RTV Elastomers formed-in-place gaskets are suitable. The gasket has to become even more flexible with the potential to flex in bowing and shearing direction due to additional integral design features such as designed gaps, chamfers or retention grooves (see Section 6).

FIGURE 3:
INFLUENCE OF FLANGE RIGIDITY ON THE USE OF STATIC GASKET TYPES DEMONSTRATED ON CAST PARTS.

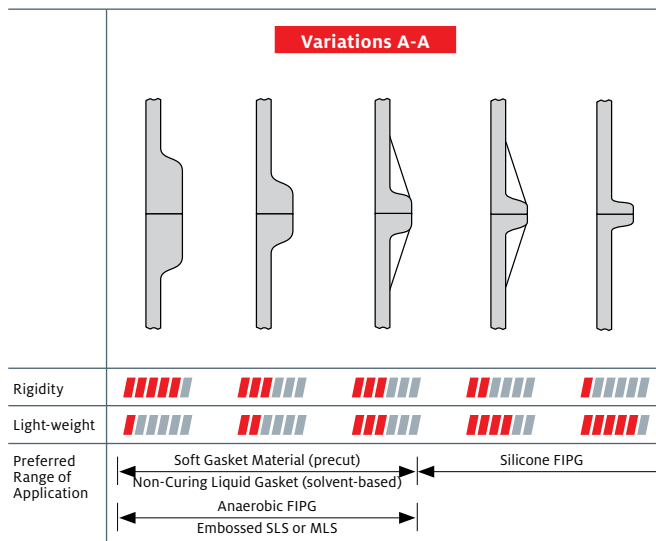
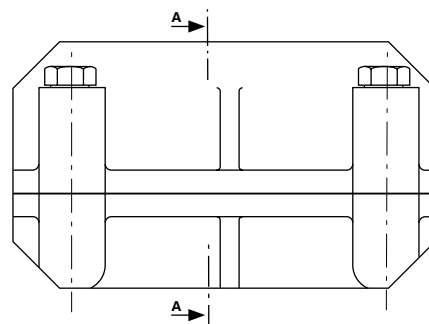

3.4 BOLT POSITIONING AND SPACING¹

The best clamping pattern is invariably a combination of the maximum practical number of bolts, even spacing, and optimum positioning.

Straight lines drawn from bolt to bolt, called bolt force lines, should be as close to the centerline of the gasket as possible to achieve uniform flange pressure distribution and avoid separation of the flanges due to potential prying (see Figure 4).

FIGURE 4:

EVALUATION OF THE DISTANCE BETWEEN BOLT FORCE LINES AND CENTERLINE OF THE GASKET IN REGARD TO THE COMPRESSIVE STRESS DISTRIBUTION IN THE SEAL GAP.¹

A-A

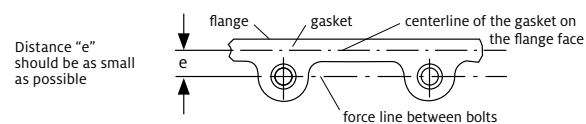
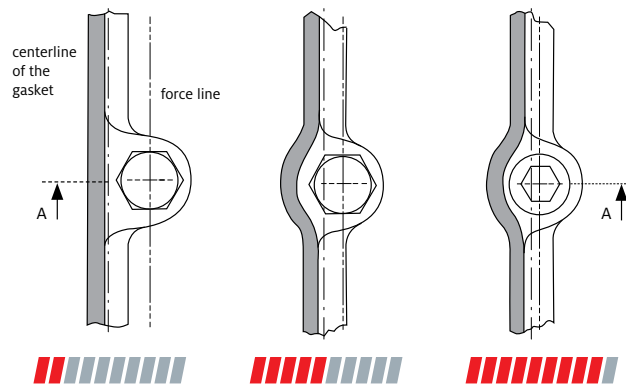
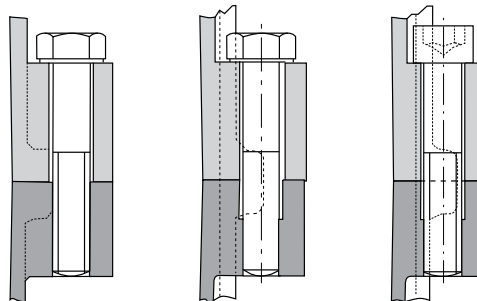

3. GENERAL DESIGN CONSIDERATIONS

In addition, the position of the bolts is very important for the design of flange corner locations. Figure 5 shows different design variations and their valuation.

FIGURE 5:

EVALUATION OF THE POSITION OF THE FORCE LINES TO THE CENTERLINE OF THE GASKET IN RELATION TO THE COMPRESSIVE STRESS DISTRIBUTION.¹

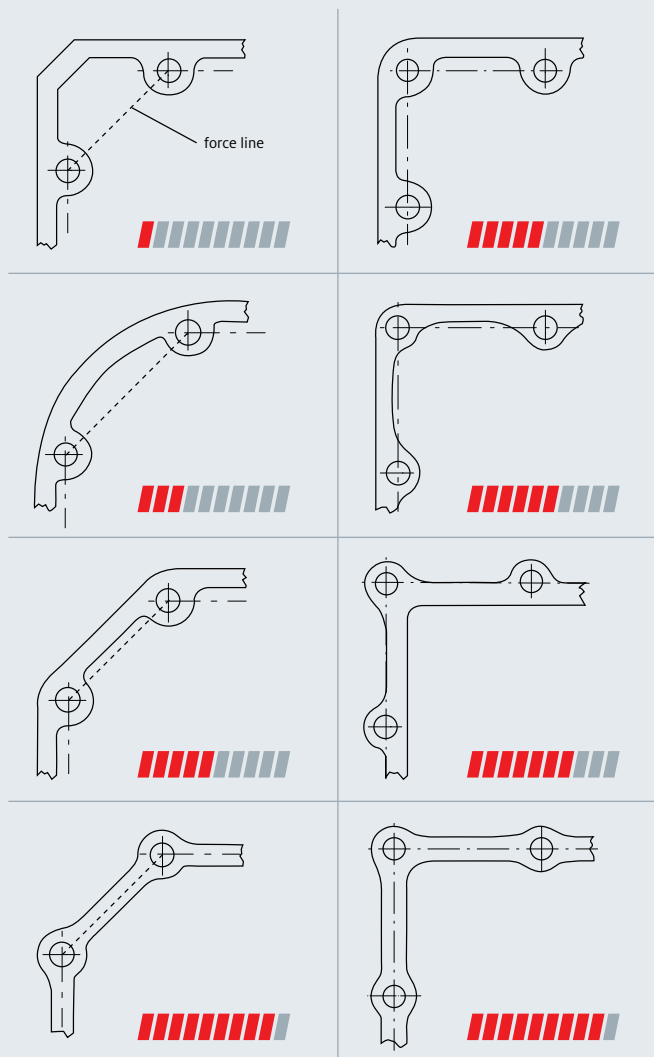

Theoretically, the bolt spacing can be calculated using the idealized model proposed by Rötischer. Rötischer's model says that the compressive stress in the flange between the bolt head and the seal gap is distributed as a cone with a half angular aperture of 45°, as shown in figure 6. For optimum bolt spacing, the pressure cones should at least touch each other or preferably overlap as demonstrated with the half angular aperture of 27°. Rötischer's model recommends overlapping cones for bolted joints without gaskets. For gasketed joints, research projects¹ have shown that touching cones with a half angular aperture of 45° or greater are useful for the calculation of bolt spacing. For highly stressed gasketed joints, bolt spacing between the two limits, 27° and 45°, is recommended.

FIGURE 6:
PRESSURE CONE
ACCORDING TO RÖTSCHER.

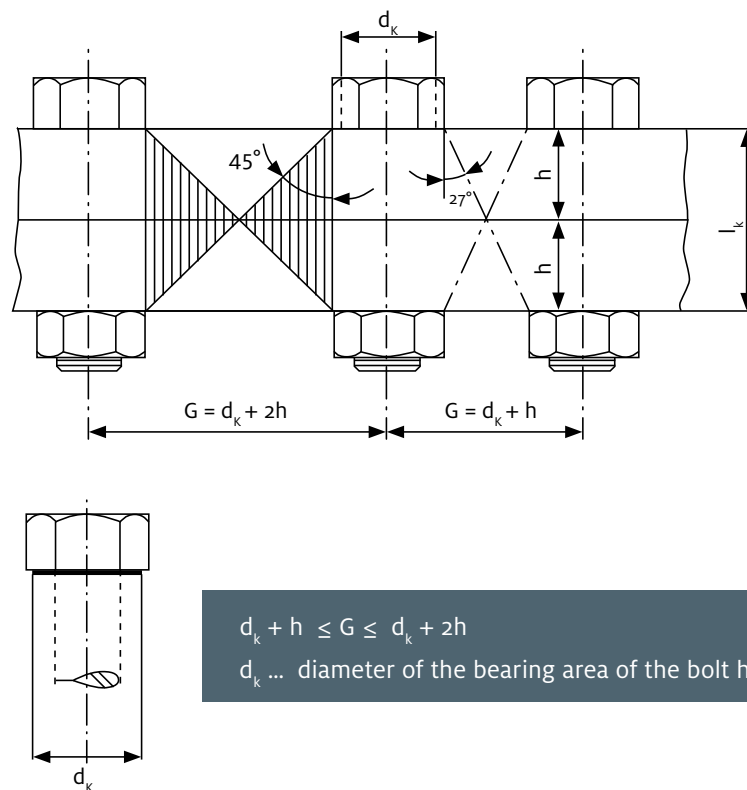

The equation shows that the flange rigidity as well as the effective bolt length are important parameters for bolt spacing. Figure 7 shows the resulting compressive stress distribution in the joint with variations of these parameters.

3. GENERAL DESIGN CONSIDERATIONS

3.5 BOLT GRADE AND LENGTH

Select a bolt where the required initial bolt load is 80% of the proof load.

Select a bolt that has an initial bolt load of roughly 3 to 3.5 times the normal operating tensile loads can be applied (internal pressure, temperature effects, and external loads).

Rule of thumb – when the length of the bolt is five times greater than the diameter, it can be elongated sufficiently to work as a spring between two flanges and dampen vibration.

Optimum thread engagement length for steel is 1.2 times the diameter of the bolt; for cast iron it is 1.5 times; for aluminum, it is 1.6 times plus the tolerance for the run out of the thread or, for dynamic loading, plus 20%.

FIGURE 7

INFLUENCE OF THE FLANGE DESIGN ON THE COMPRESSIVE STRESS DISTRIBUTION OF THE FLANGES.¹

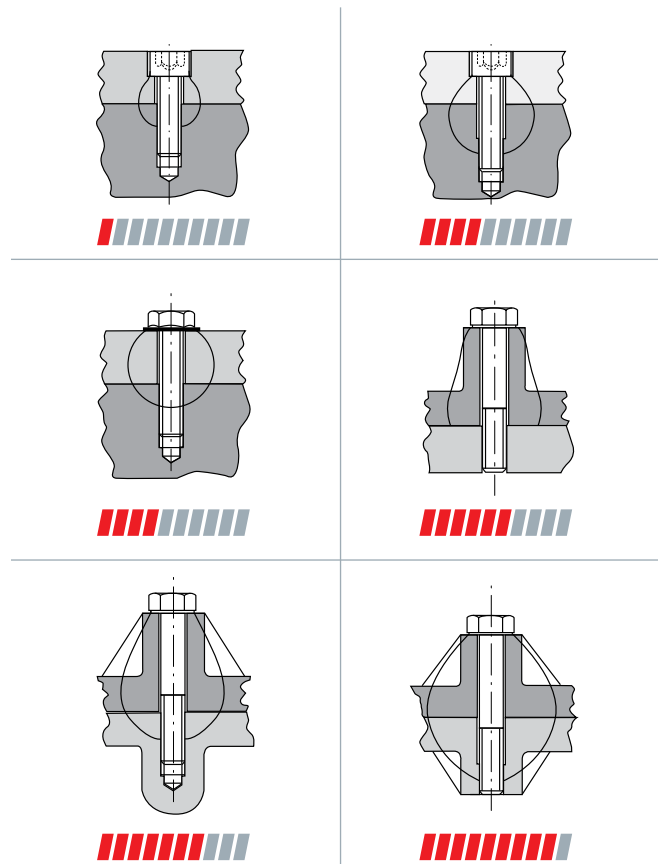

3.6 FLANGE DESIGN VERIFICATION

One of the basic rules for the design of highly stressed gasketed joints is to achieve a uniform flange pressure distribution within the gasket-specific permissible limits. It is necessary to know in the early stages of the design process if the required flange pressure is achieved in the seal gap.

The flange pressure distribution can be evaluated in a very early state with a Finite Element Analysis (FEA) or later on using prototypes with a pressure sensitive film, manufactured by Fuji Photo Film Company. A completely new design will rely on both systems since the FEA allows the design optimization in a cost-effective way and the imprint of the pressure sensitive film is needed for the confirmation of the numerical calculation.



To evaluate the stress distribution, the film is pre-cut to the shape of the mating flanges and holes are pre-punched for the fasteners. The film is then placed between the flanges and the bolts tightened to the specified torque. When pressure is applied, microcapsules break and a color-forming material is released. The microcapsules are adjusted to break at different pressure levels, with the resulting color density dependent on the amount of pressure. Thick red color indicates the applied pressure is high while fainter shades indicate the applied pressure is low. Using a commercially available Fuji densitometer, impression color density can be directly converted to stress readings.

A disadvantage of the system is that only the maximum applied force is recorded, whereas the unloading of the gasket under operating conditions such as temperature, pressure or dynamic loads cannot be measured. These effects have to be evaluated by FEA. The film gives an indication of the weak points in gasketed joints, such as areas with low or no flange pressure, and focuses the FEA on these points for optimization. The film also shows machining marks and problems with flange mating tolerances, such as flatness and overlapping.

Besides the FEA, real-time flange pressure mapping is possible with the Tekscan thin-film pressure profile measurement system at the prototype stage. With the Tekscan system, a high resolution, matrix-based tactile sensor is placed between the flanges. The software supplied with the sensor is capable of dynamic data collection and display where pressure cycling or the recording of an event might be important.

3. GENERAL DESIGN CONSIDERATIONS

3.7. SURFACE FINISH

Surface finish or surface textures are terms used to describe the general quality of a workpiece surface. Surface finish consists of roughness, waviness, lay and flaws. Bearing and locating surfaces usually require close dimensional and surface finish control for proper functioning.

The surface finish is most important for conventional gaskets, since the initial compressive load required to deform the gasket into the flange surface irregularities increases with rougher surface finish.

For FIP sealants, the surface roughness has no influence on the initial compressive load because the product is in the fluid state during the assembly process; however, it does have an effect on the formation of the sealant layer thickness.



At higher surface roughness $R_a \geq 3.0 \mu\text{m}$ (ten point height $R_z \geq 17 \mu\text{m}$), metal-to-metal contact is achieved independent of the compressive stress.

At lower surface roughness $R_a \leq 0.3 \mu\text{m}$ (ten point height $R_z \leq 3 \mu\text{m}$), FIP sealants tend to generate an adhesive layer which decreases with increasing flange pressure. Metal-to-metal contact is achieved only in the areas near the bolts. (The actual metal-to-metal contact between the most carefully finished interfacing parts does not exceed 25-35%.)

Smoother surface finish aids cleaning and ensures removal of surface contamination before sealant application

Blowout resistance decreases with increasing gaps. Therefore, surface finish is important for blowout pressure tests during assembly, when the FIP sealant is still in the uncured state.

The surface characteristics are determined primarily by means of electrical stylus instruments according to DIN EN ISO 4287:1998 (ANSI B46.1-1971). The two most common measurements of surface finish are R_a and R_z , as shown in figure 8.

FIGURE 8:

RA AND RZ ACCORDING TO DIN EN ISO 4287:1998 [ANSI B46.1-1971].

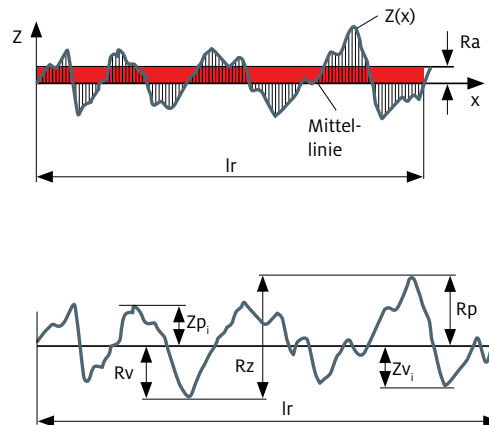

$$Ra = \frac{1}{l_r} \int_{r_0}^{l_r} |Z(x)| dx$$

Ra is the mean value of the absolute values for the profile deviations within one individual measurement section l_r . Rz is the maximum peak-to-valley height within one individual measurement section l_r .

The formerly used ten point height uses Rz, which is the mean value of the absolute values of the heights of the five highest peaks and of the five highest valleys for five individual measurement sections within the evaluation length ($Rz \geq$ ten point height Rz).

The Ra value alone is not sufficient to determine roughness, since different surface textures can have the same Ra value, as visualized in figure 9. At least Ra and Rz should be measured, but using Ra, Rz, Rmax and Wt provide a more accurate picture.

Maximum peak-to-valley height, Rmax, is the greatest individual peak-to-valley height of the entire measurement section $l_n (= 5 \times l_r)$.

Wt is the maximum profile height of the filtered waviness profile within the entire measurement section l_n .

3. GENERAL DESIGN CONSIDERATIONS

FIGURE 9:

DIFFERENT PROFILES WITH THE SAME RA VALUES.

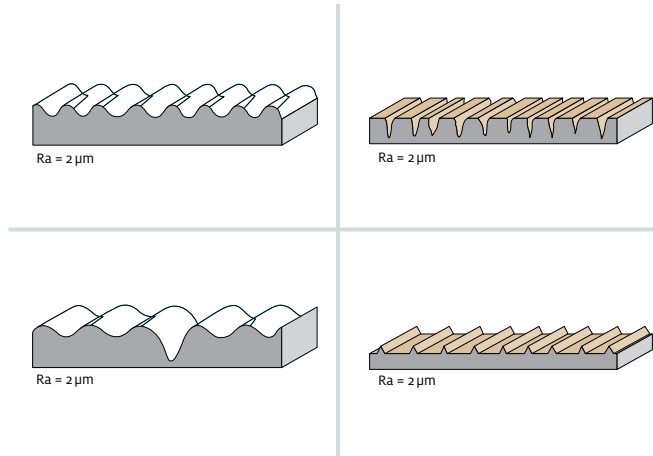

General Guidelines for Flange Surface Roughness

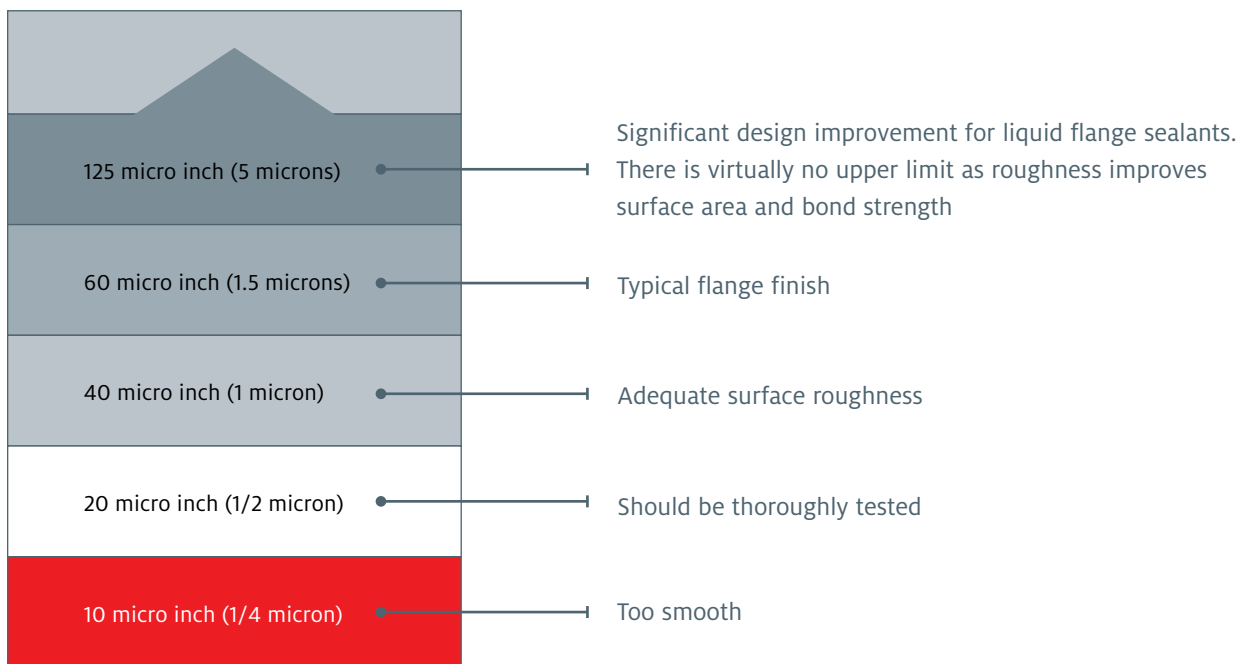

4. FIPG APPLICATION AREAS, ADVANTAGES OVER SOLID GASKETS

Unlike conventional gaskets, FIP technology does not require extreme compressive loading to form a seal, due to the adhesion of the cured FIPG to all the members in the joint. The main benefits of FIP over solid gaskets are:

- No gasket relaxation** – FIP sealants allow metal-to-metal contact in most applications, which ensures correct bolt tension throughout the life of the assembly and eliminates the need for retorquing.
- Non-shimming** – The metal-to-metal contact eliminates the need for gasket thickness, so tolerances can be more accurately maintained.
- Relaxed surface finish** – FIP sealants allow relaxation of surface finish and flatness tolerances. Scratches and scored surfaces can be sealed without reworking the damaged surfaces.
- Chemical compatibility** – FIP sealants demonstrate good to excellent solvent resistance.
- Reduced inventory costs** – FIP sealants can seal different flange geometries, unlike solid gaskets that require stocking many different gaskets to fit the different geometries.
- Automatic application** – FIP sealants can be applied by fully automated robotic dispensing or screen or stencil printing systems.
- Easier handling of vertical components** – FIP sealants can be applied to both horizontal and vertical flange faces. Unlike solid gaskets, they do not require additional adhesive to maintain their position on vertical flange faces.
- Reduced hydrocarbon emissions** – The reduced seal gap decreases hydrocarbon emissions compared to solid gaskets.

4. FIPG APPLICATION AREAS, ADVANTAGES OVER SOLID GASKETS

To achieve the required sealing performance on a wide range of flanges, 2 types of FIP sealants are frequently used:

Anaerobic sealants

Room temperature vulcanizing RTV Elastomers

ANAEROBIC SEALANTS

Anaerobic sealants cure in the absence of air and the presence of active metal surfaces. These products are best suited to seal rigid flanges, which are designed to:

Achieve optimum stiffness between two mating parts

Minimize movement between two parts

Transmit forces from one part to another

Typical examples of rigid flanges are found in vehicles including gearbox housings, bedplate to crankcase, water pump to engine block, and cam cover to cylinder head.

Anaerobic FIP sealants are used for rigid bolted joints because they:

Offer metal-to-metal contact

Ensure correct bolt tension

Accurately maintain final dimension tolerances

Add structural strength and reduce micromovement

Can be easily disassembled by applying a cleavage load to the joint

Offer high-pressure resistance if sufficient clamp load is provided

Remain in liquid form; unlike other FIP sealants, anaerobic sealants cure only between flange faces. Excess material can be wiped away from exterior surfaces or flushed away from interior surfaces (liquid sealants are miscible in many fluids, e.g., oil).

Offer extensive on-part life when exposed to air – making multiple application methods possible, and reducing the problems associated with the use of volatile and/or moisture-cured sealants.

ROOM TEMPERATURE VULCANIZING RTV ELASTOMERS

RTV Elastomers cure to a rubbery solid by reacting with moisture in the environment. These products are best suited to seal flexible flanges, such as gearbox covers, timing chain covers, stamped sheet steel parts, thin-walled metal castings, and oil pans. Unlike rigid flanges, they do not usually support the function of the component, therefore micromovement between the flanges can be tolerated and an optimum clamp load distribution is not necessary.

Flexible flanges are normally used to:

- Cover an opening in a housing
- Seal a liquid inside a component or protect it from external contamination
- Cover moving parts to increase safety
- Encapsulate components to reduce noise

Apart from flexible flanges, there are additional types of flange designs that require flexible gaskets, such as:

- Parts where the required compressive stress distribution for anaerobics cannot be achieved
- Assemblies with different flange materials and large differences in their thermal expansion coefficients, which can result in bowing of the flanges
- Flanges where more than two parts are mounted together, forming T-joints

RTV Elastomers can be used for flexible joints as well as for stiff joints, and offer a number of benefits, including:

- High-gap filling
- Capability to seal joints with micromovements
- Ensuring metal-to-metal contact
- Achievement of correct bolt tension with no setting
- Sealing of T-joints
- Creating seals on non-machined flanges
- Potential for robotic application also for AN gaskets
- Creating seals between metal and plastic components or even between plastic and plastic materials

5. DESIGN RECOMMENDATIONS FOR ANAEROBIC FIPGS

To achieve optimum seal performance on rigid bolted joints, the general design considerations of Section 3 should be observed. In addition, several design features specific to anaerobic FIP sealants should be followed, including:

Machined flanges with surface characteristics:

- Ra 0.8 to 3.2 μm
- Rz 3 to 21 μm (10 point height)
- Rmax 4 to 30 μm
- Flatness 0.1 mm @ 400 mm

A minimum overlapping flange width of 5 mm (to ensure reliable curing)

A minimum overlapping flange width around bolts of 3 mm (to ensure reliable curing)

Chamfer dowel and bolt holes to eliminate raised metal and shimming

The maximum gap at surface imperfections or machining marks must be within the maximum cure through volume range (0.1 to 0.25 mm sealant dependent)

Typical minimum flange contact pressure for passenger car applications of 2.5 MPa

Use alignment dowels for assembly of large parts to prevent smearing of the sealant and ensure accurate positioning of the two mating surfaces

Conduct instant seal tests at least 20 minutes after assembly with test pressures ≤ 0.03 MPa/0.3 bar/4.3 psi for minimum possible duration



FIGURE 10:

FLANGE DESIGN FOR ANAEROBIC FIP SEALANTS.

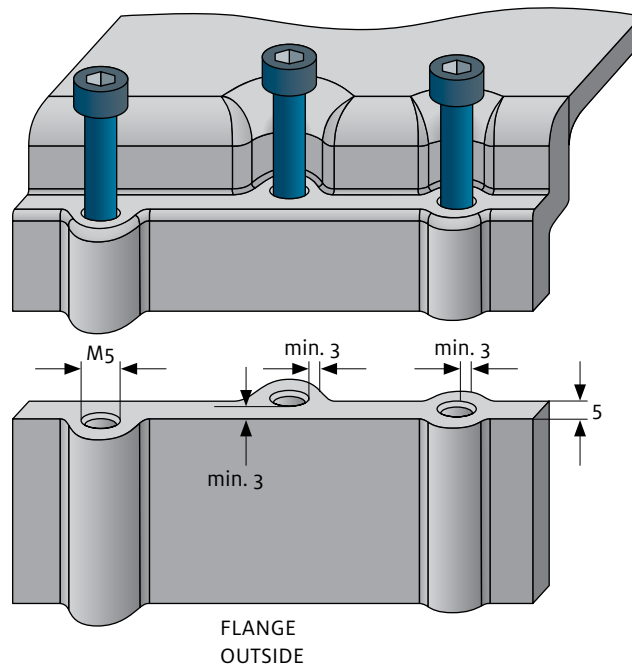

In addition to the correct design of the flange, reliable sealing with FIP gaskets depends on adhesion to the flange surface. The adhesion is strongly influenced by the cure performance. The anaerobic cure starts when atmospheric oxygen is excluded. Then free radicals are formed and under the effect of metal ions (Cu, Fe), these free radicals initiate the polymerization process.

Reliable curing and maximum adhesion are achieved by:

Cleaning the flange faces

Using activators or heat for substrates which are less active (stainless steel, high-alloy steel, aluminum with low copper content, anodic coatings, or chromate films)

6. DESIGN RECOMMENDATIONS FOR RTV ELASTOMERS

RTV Elastomers are able to seal joints with poor flange design and also critical areas such as T-joints, where anaerobic sealants or hard gaskets will have problems. Nevertheless, the general design considerations of Section 3 should be followed to achieve a reliable, durable seal.

WHY CHAMFER?

Performance tests and experience showed that an inside chamfer often is the best design to seal a joint when using RTV Elastomers. The main advantages of using a chamfer include:

Defined flow of product

- No release of product pieces due to squeeze-out

Defined, filled gap

- Good durability because of product layer (in the chamfer)

Fast curing

- Product is fully cured when supplied to final customer

Easy manufacturing

- Cast surface leads to cost reduction

Low product consumption

- Cost reduction

Oil exchange

Guide for manual dispensing

- Quick for manual dispensing



6.1 BASIC FLANGE DESIGN

Flanges with surface characteristics as diverse as stamped sheet steel and cast surfaces can be sealed.

The following recommendations are important for designing a joint sealed by a RTV Elastomer:

Recommended surface characteristics:

- Ra 0.5 to 8 μm

- Rz 5 to 90 μm (10 point height)

- Rmax < 100 μm

Flatness of both parts has to be defined in a way to avoid gaps of more than 0.3 mm between flange surfaces

Maximum gap of 0.3 mm to allow an instant seal test after 20 minutes with 0.05 MPa/0.5 bar/7.2 psi or an early engine start (related to flow characteristics)

Minimum overlapping flange width of 5 mm not including the chamfer (for instant sealing capabilities)

Minimum overlapping flange width of 3 mm around bolts, not including the chamfer (for product dispensing)

Inside cast chamfer width 2 mm minimum with angle 30° or alternative stamped inside radius 4.5 mm (for long-term sealing capability)

Chamfer or radius only on one flange must be fully covered by mating part in all areas (see Figure 11)

Use alignment dowels for assembly of large parts to prevent smearing of the sealant and ensure accurate positioning of the two mating surfaces

When filling the chamfer area:

- The minimum defined chamfer area has to be completely filled

- Completely fill the minimum overlapping flange as shown in Figure 11

6. DESIGN RECOMMENDATIONS FOR RTV ELASTOMERS

When the required minimum surface pressure for anaerobics is not achieved, the gasket has to become more flexible. In those cases, RTV Elastomers are able to cope with movements in bowing and shearing direction due to their flexibility and integrated design features (e.g., chamfer).

It is obvious that the missing surface pressure and the movements also require an RTV Elastomer sealant with excellent adhesion to the substrate.

High adhesion and a reliable seal can only be achieved by:

- Properly cleaning the flange faces
- Selecting the correct product
- Assembling the parts within the skin-over time as listed on the Technical Data Sheet
- Ensuring the correct product quantity – typical bead size is 2.5 ± 0.5 mm (passenger car applications)
- Ensuring the correct bead location – always apply on the flat flange area, located 1 mm from the start of chamfer as shown in Figure 12
- Dispensing on either side of the joint if possible – not necessary to apply on the chamfered side

FIGURE 11:

FLANGE ALIGNMENT.

WRONG ▼

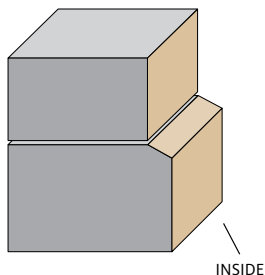

CORRECT ▼

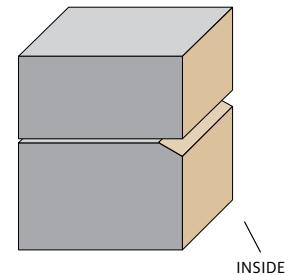
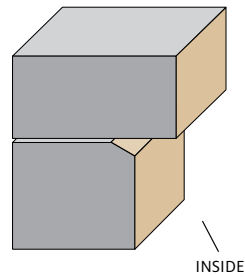

FIGURE 12:
CHAMFER DESIGN.

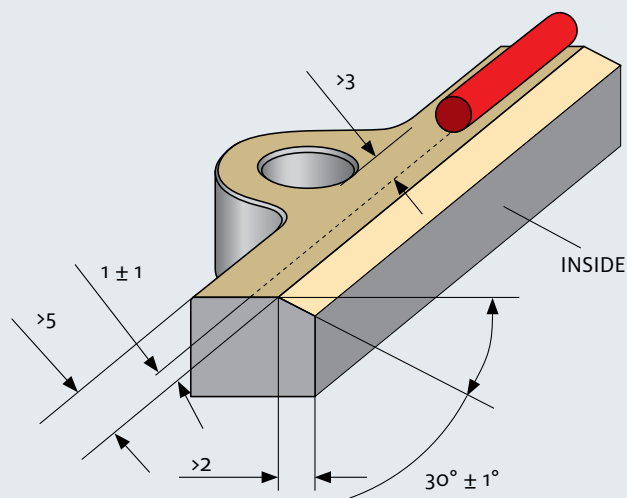
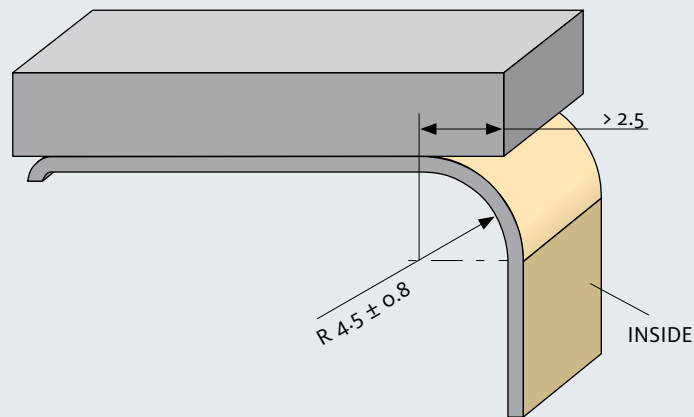

FIGURE 12:
RADIUS DESIGN FOR STAMPED PARTS.



6. DESIGN RECOMMENDATIONS FOR RTV ELASTOMERS

6.2 ALTERNATIVE DESIGN

CHAMFER-STEP

RTV Elastomer sealants usually need many hours to achieve a full cure. In areas where the uncured RTV Elastomer sealant can come in contact with the flowing media (e.g., oil pressure bores during an early engine start), a standard chamfer design is not sufficient. The liquid RTV Elastomer sealant might be washed away. To avoid direct contact with the flowing media, add an additional step to protect the RTV Elastomer sealant.

FIGURE 14:

CHAMFER-STEP DESIGN / USE: E.G., FOR HIGH PRESSURE HOLES.

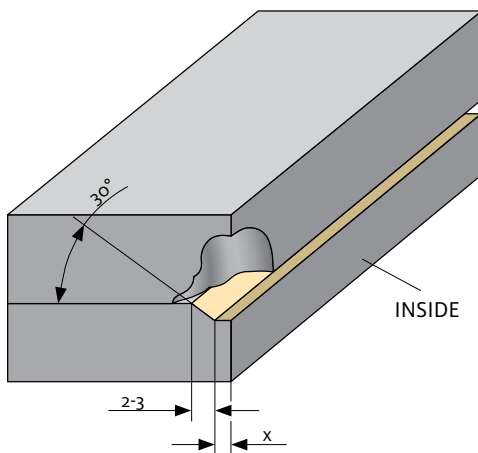

For this design, only the chamfer area has to be completely filled with RTV Elastomers.

Dimension x must be able to pick up all the sealant that will be extruded through the chamfer. Worst case dimensions must be taken into account. Common dimension for x is 2 mm.

CHAMFER-GROOVE

On a real flange, a simple chamfer design often cannot be used in areas close to additional supporting bolts or bearings. The only possible design feature is a groove. To achieve fast curing, good product flow and dispensing freedom, a 30° chamfered groove on one side is the best solution.

The groove should be designed to avoid completely filling it with sealant, even under the worst case conditions (maximum product volume with minimum groove size). This can be achieved by designing a wider chamfer, having a wider flat bottom of the groove, or using both design elements.

FIGURE 15:

CHAMFER-GROOVE DESIGN / USE: E.G., FOR BEDPLATE.

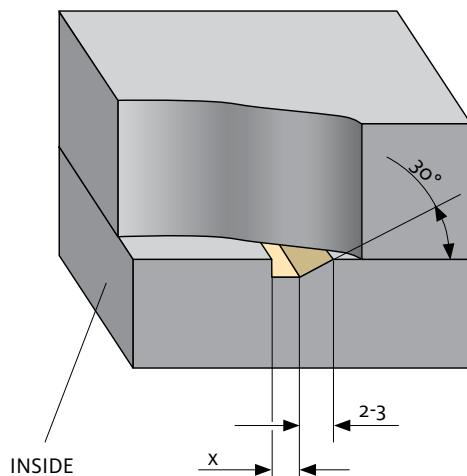

Note:

The groove chamfer never has to be completely filled with RTV Elastomer sealant, even under worst case tolerance conditions.

Only the chamfer area has to be completely filled with sealant. Common dimension for x is 2 mm.

6. DESIGN RECOMMENDATIONS FOR RTV ELASTOMERS

GROOVE

The groove design, in general, is not recommended for RTV Elastomer sealants because of the long curing time of the entrapped product. In addition, excess sealant can squeeze out at both the inside (fluid side) and outside of the flange. The excess sealant on the fluid side can break off and contaminate the engine fluid being sealed. On the outside edge the excess squeeze-out can cause cosmetic concerns. Even under worst conditions, the groove must be completely filled.

Common groove shape is a semicircle:

width: 3.0 + 0.5 mm typical

depth: 1.5 + 0.5 mm typical

distance groove/bolt holes: 2 to 3 mm typical

T-JOINTS

The most critical areas to seal are where three sealing surfaces meet each other, known as the T-joint. The typical gaskets that will exist at a T-joint are FIPG, SLS (single-layer steel), MLS (multi-layer steel), or molded rubber types (press-in-place gasket, backbone carrier gasket, void-volume carrier gasket, edge molded carrier gasket, etc.) Special attention should be paid to joints when sealing with FIPG hard gaskets. To achieve a reliable seal, focus on the correct design and the tolerance of these joints, as well as on the assembly process and the product dispensing (see also Section 7.2 Dispensing).

The general rule is to avoid gaps of more than 0.3 mm under the worst conditions.

There are several possible scenarios:

- A) When sealing anaerobic to RTV Elastomers, the flange with the anaerobic always has to be assembled first to avoid curing and adhesion problems. Excess squeeze-out on the T-joint surface must be wiped off prior to applying the RTV Elastomers on the second sealing surface.
- B) When sealing RTV Elastomers to RTV Elastomers, a continuous chamfer at the inside has to be formed after assembly (see Figure 16).

- C) When sealing RTV Elastomer to molded hard rubber, cork, or metal gaskets, there are two possibilities:

When the first assembled joint is RTV Elastomer sealant and the second assembled joint is molded rubber, apply enough RTV Elastomer sealant to provide squeeze-out at the T-joint. Excess squeeze-out must be either wiped off or the mating parts must be assembled within the recommended RTV Elastomer sealant open time.

For the second assembled joint, the molded rubber gasket should incorporate a flat pad at the T-joint location. An RTV Elastomer sealant “dollop” must be dispensed at the T-joint location on the first flange position at the T-joint centerline (split line).

When the first assembled joint is the molded rubber gasket and the second assembled joint is the RTV Elastomer sealant, enough RTV Elastomer sealant must be applied to the second assembled joint to provide squeeze-out at the T-joint. The recommended position for the molded rubber gasket is normally flush to the surface of the T-joint. The molded rubber gasket may not protrude more than 0.5 mm at the end of the flange and the gasket recession must not be greater than 0.5 mm.

- D) When sealing a SLS or MLS to RTV Elastomer sealant gasket, the first assembled joint is the SLS or MLS and the second assembled joint is the RTV Elastomer sealant. Apply sufficient RTV Elastomer sealant to the second assembled joint to provide squeeze-out at the T-joint. The SLS or MLS gasket must be greater than 0.5 mm thick and be flush (no protrusion allowed) to 1 mm recessed maximum. The RTV Elastomer sealant bead size for the T-joint will depend on the flange design of the second assembled joint with additional RTV Elastomer sealant at the T-joint. It is not recommended to have a T-joint design where the first assembled joint is the RTV Elastomer sealant and the second assembled joint is the SLS or MLS gasket.

When sealing to the SLS or MLS gasket, the RTV Elastomer sealant should have good contact to the sealing area of the hard gasket. Adhesion to the SLS or MLS gasket is essential. The hard gasket has to have sufficient surface pressure even at the end of the joint to avoid leakage through the hard gasket and movement of the hard gasket relative to the flange surfaces (different thermal expansion). One way to better cope with such relative movements is to integrate a semi-chamfer similar to Figure 16 (with no inside chamfer). See also Figures 17 and 18.

6. DESIGN RECOMMENDATIONS FOR RTV ELASTOMERS

- E) When sealing a SLS or MLS gasket to molded rubber gaskets, the first assembled joint is the SLS or MLS gasket and the second assembled joint is the molded rubber gasket. The SLS or MLS must be greater than 0.5 mm thick and be flush (no protrusion allowed) to 1 mm recessed maximum. For the second assembled joint, a flat pad at the T-joint should be incorporated into the molded rubber gasket at the T-joint location to allow a maximum width to assist in sealing the joint. An RTV Elastomer sealant “dollop” of typically 8 mm in diameter at the base must be dispensed at the T-joint location on the first flange positioned at the T-joint centerline. Again it is not recommended to have a T-joint design where the first assembled joint is the molded rubber gasket and the second assembled joint is the SLS or MLS gasket.

FIGURE 16:

FLANGE GEOMETRY FOR RTV ELASTOMER SEALANTS AT T-JOINT.

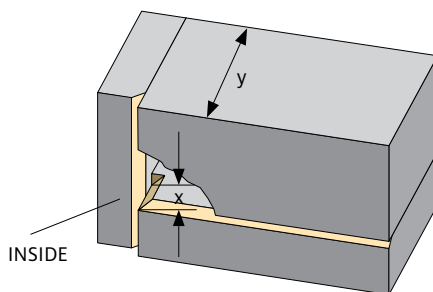

The dimension x always has to be smaller than the overall flange width y .
Common dimension:
 $x = 3 \text{ mm}$ ($y - x > 3 !$)
The minimum recommended flange width y is 10 mm.

FIGURE 17:

RECOMMENDED FLANGE GEOMETRY FOR RTV ELASTOMER SEALANTS AT T-JOINT WITH HARD GASKET (IN BLUE).

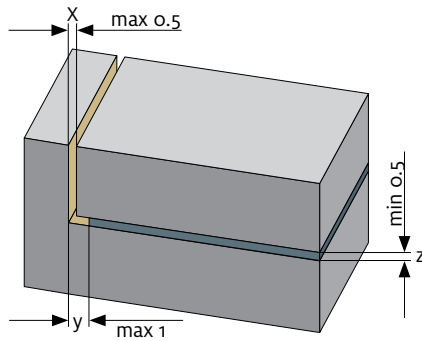

Machining and positioning tolerances may cause gap x to be up to 0.5 mm and above. Dimension y may be 0.8 mm or more. Gasket thickness z may exceed even 0.8 mm. In those cases it is necessary to understand the assembly procedure in detail and know the timing for cold or hot tests with the maximum occurring pressure and duration. Further, it will be necessary to apply more sealant at the T-joint (see also under Section 7.2, figure 20). Verification tests under worst-case conditions are a must.

FIGURE 18:

ADDITIONAL CHAMFER AT T-JOINT IS NOT RECOMMENDED. THERE IS A RISK OF LOSING PRESSURE ON HARD GASKET AND POOR INSTANT SEALING CAPABILITY.

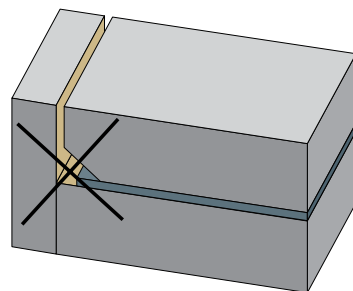

7. PRODUCT DISPENSING AND ASSEMBLY

In volume production, the following points have to be considered:

7.1. CLEANING

All manufactured parts must be cleaned after machining. To achieve consistent quality of the cleaning process, the procedures provided by the detergent supplier should be followed.

In general, RTV Elastomer sealants are less sensitive to contamination than anaerobics.

ANAEROBICS:

For anaerobics, both surfaces must be clean and dry before dispensing and assembly. Contamination on the flange could inhibit the cure of the product or reduce the adhesion to the substrate.

RTV ELASTOMER SEALANTS:

RTV Elastomer sealants also need clean, dry flanges to achieve a high quality and durable seal. Wet or oily surfaces could reduce the adhesion significantly and the dispensed bead could slip away from the correct position, which would impact the sealing performance.

GENERAL:

It is recommended to run basic adhesion tests with the production washing solution. Test conditions should be worst-case scenarios.

7.2. DISPENSING

ROBOT DISPENSING

The most flexible and reliable way to apply any kind of sealant is robotically or using an XY-Table. For this reason, Henkel recommends this technology especially for high-volume production.

Henkel has developed its own dispensing systems that are able to apply high-viscosity anaerobics and RTV Elastomer sealants with high speed and excellent quality.

Quality systems like flow monitors or visual inspection systems are recommended to achieve consistent high quality.

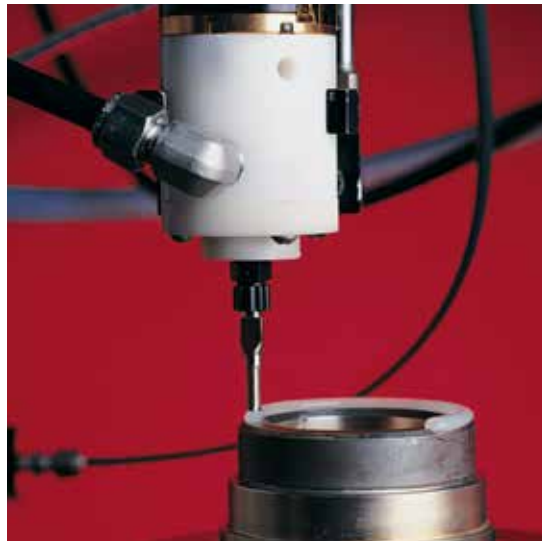

Example for Anaerobic

Bead diameter 1.5 ± 0.5 mm

Position the bead on the centerline of the mating surface with an accuracy of ± 1 mm

Apply a continuous bead of material inside or around dowel and bolt holes

Inspect the bead for uniform thickness, air pockets, voids, and continuity

Distance between nozzle tip and the flange should be $(1.3 \pm 0.2$ mm) bead diameter

Dispensing speed of 80 to 130 mm/sec

FIGURE 19:

ANAEROBIC PRODUCT BEAD ON GEARBOX FLANGE.

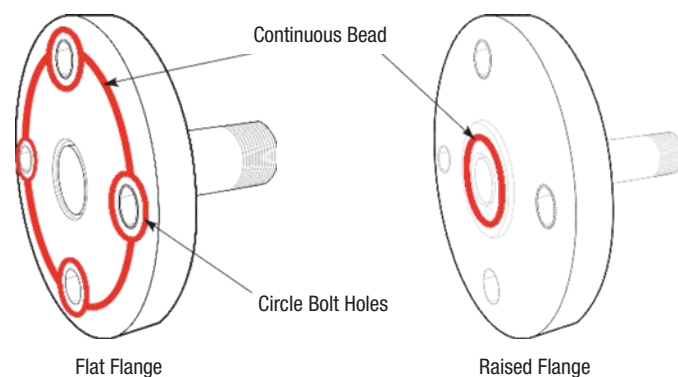

7. PRODUCT DISPENSING AND ASSEMBLY

Example for RTV Elastomer Sealant

Bead diameter 2.5 ± 0.5 mm

Positioned on flat flange area, center of bead 1 ± 1 mm from chamfer

Apply a continuous bead of material inside or around dowel and bolt holes

Inspect the bead for uniform thickness, air pocket voids, and continuity

Distance between nozzle tip and flange should be $(1.3 \text{ mm} \pm 0.2 \text{ mm})$ bead diameter
(See also under Section 6.1 / Figure 12)

Dispensing speed 80 to 130 mm/sec

Note: T-joints may require a higher amount of RTV Elastomer sealant product. An increased bead diameter or a special dispensing path are proper ways to fill the void in that area. Dispensing studies are required to evaluate the correct product quantity. When a “dollop” is required to seal a T-joint, it is typically 8 mm diameter at the base.

FIGURE 20:

POSSIBLE RTV ELASTOMER SEALANT BEAD ON T-JOINT.

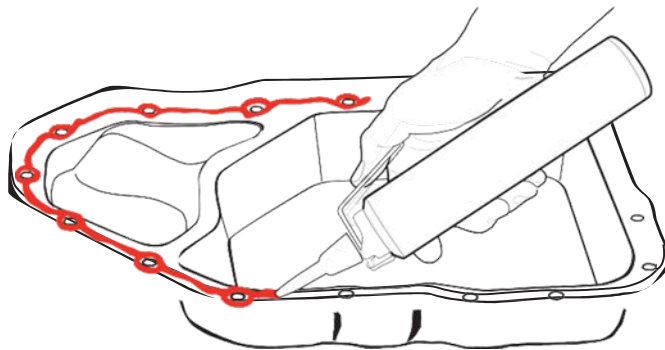

SCREEN PRINTING

This process can be used to apply anaerobics. Screen printing is especially suitable for medium scale production, and where flexibility is not required.

A flat surface (e.g., no dowels) is necessary for the screen printing process.

Screens do wear and, therefore, have to be replaced from time to time.

Screen printing cannot be used for the application of RTV Elastomer sealants.

7.3. ASSEMBLY

It is essential to understand the procedure on the assembly line where FIPGs will be used. The assembly conditions, steps and cycle times have a major effect on the selection of the sealant, and later on the quality of the whole process.

It is important to avoid contamination of the flanges prior to assembly of the parts. When parts have to be moved, the dispensed product has to stay in place. The product should never be touched before assembly.

Quality inspection systems can help monitor dispensing and detect bead misplacement or bead interruption.

Once the applied product connects with both flange surfaces, any movement relative to the joint surface must be avoided.

ANAEROBICS:

The basic curing chemistry of anaerobic sealant allows an unlimited open time. Nevertheless, fast curing sealants can start to pre-cure even before assembly. This so-called shimming effect will influence the sealing performance and cause a gap between the joint surfaces.

It is highly recommended to fully torque down all bolts immediately after joining the flange faces to avoid shimming and, later, leakage. Sub-assembled parts may require slave fasteners.

RTV ELASTOMERS:

Once the product is dispensed, the flanges have to be assembled within the skin over time of the product (approximately 5 to 15 minutes for most products, refer to TDS). Full torque down is not immediately necessary. Depending on the size and stiffness of the flanges, it is allowable to run down several bolts first, with full torque run down to follow within 20 to 30 minutes.

IMPORTANT:

Line shutdown or breaks must be taken into account. Proper planning of the assembly line can avoid the need for scrap or reworking of parts.

8. SERVICE AND REPAIR

Service and Repair

8.1. DISASSEMBLY

With the correct design, product and process, the joint will maintain the sealing capability throughout the life of the vehicle. Disassembly will, therefore, only be necessary for mechanical repair.

DESIGN FOR DISASSEMBLY – ANAEROBIC / RTV ELASTOMER SEALANTS:

A highly effective and inexpensive method for disassembly is to implement special design features during component development.

The following pictures show two ways to achieve this: Depending on part size and accessibility, two or more of those bosses or recesses are needed on each joint.

FIGURE 21:

POSSIBLE DESIGN FEATURES FOR EASY DISASSEMBLY OF CAST PARTS. IN SOME CASES, ACCESSIBILITY OR SPACE REQUIREMENTS MIGHT LEAD TO THE USE OF JACK SCREWS. THE HOLES USED FOR BOLTING THE PARTS CAN BE USED AS JACK SCREW HOLES.



DISASSEMBLY TOOL – RTV ELASTOMER SEALANTS

Another common disassembly procedure, especially for stamped parts, is the spatula + hammer method (see Figure 22). This is valid for OEMs as well as service garages. The spatulas have to be partially modified depending on the access and handling conditions. The front and side edge should be sharpened for easy insertion and easy cutting.

The main advantages of this method are:

- Good availability – every tool box is equipped with those tools
- Little to no surface damage
- Mechanics are used to this technique – used also for hard gasket disassembly
- Low cost
- For both cast aluminum and stamped steel oil pans
- Compatible to the most common engines

8. SERVICE AND REPAIR

8.2. CLEANING

For FIP gaskets, it is essential to have an appropriate cleaning process in place to achieve a high quality seal.

After the disassembly of the parts, both flange surfaces must be cleaned and inspected.

ANAEROBIC

Old gasket residues must be completely removed to avoid shimming, which could cause a gap.

All dirt or fluids must be removed from the sealing surfaces to guarantee good product curing and adhesion to the substrate.

Contamination of the flanges prior to the assembly must be avoided. Therefore, it might also be necessary to clean parts or areas in the neighborhood of the sealed joint.

RTV ELASTOMER SEALANTS

The old gasket must be removed. Depending on the application, small amounts of residue are acceptable because, generally, the fresh RTV Elastomer sealant has good adhesion to old RTV Elastomer sealant. If shimming is an issue, the flange must be completely clean to avoid any gap or mispositioning.

FIGURE 22:

EXAMPLE OF SPATULA WITH A PLASTIC HAMMER.



Dirt or fluids must be removed from the sealing surfaces. The product must be applied to a dry flange.

Contamination of the flanges prior to the assembly must be avoided. Therefore, it might also be necessary to clean parts or areas in the neighborhood of the sealed joint.

CLEANERS AND TOOLS

Loctite SF 7200 Parts Cleaner - Gasket Remover

LOCTITE SF 790 Gasket Remover

Spatula, plastic scraper

Scour Pads

Do not use petroleum cleaner or mineral spirits that leave a residue and prevent adhesion or curing.

8.3. APPLICATION AND ASSEMBLY

For service, the only practical application method for a FIPG is manual bead dispensing.

It is important to describe where the product has to be dispensed and in what quantity. This should be shown in the service manual.

Apply sealant to only one of the sealing surfaces.

Inspect bead position, quantity and continuity, and repair imperfections immediately after dispensing.

ANAEROBICS:

Anaerobic products should be applied in a straight line in the middle of the flange (like robot application in volume production). The quantity must follow recommendations shown under Section 7.2 Dispensing.

RTV ELASTOMER SEALANTS:

When dispensing RTV Elastomer sealants, it is usually easier to find the proper bead location when the product is applied on the part with the chamfer. The location and quantity of the bead has to follow recommendations shown under Section 7.2 Dispensing.

9. SCOPE AND LIMITATIONS

This guideline is based on Henkel application experience of more than 25 years, fortified by extensive testing done in the GEC in Munich since 1991. With the knowledge we have accumulated, Henkel is able to demonstrate how a reliable seal can be achieved.

The content should be used to assist during development or to discuss occurring failures in the field. It can also be used to optimize existing flanges.

The guideline cannot replace detailed discussions between customer and the local Henkel sealing expert. Experience shows that every flange and application is different and, therefore, in-depth knowledge of product, design and process is necessary to find the best solution for each case. Exceptions to the given rules might be required and should be verified.



10. ABBREVIATIONS

- SLS** Single-Layer Steel – A gasket constructed from a single layer of steel. Typically, the steel will include an embossed sealing bead and may incorporate an additional surface coating or treatment.
- MLS** Multi-Layer Steel – A gasket constructed from two or more layers of steel. Typically, one or more layers will include embossed sealing beads and the gasket may incorporate an additional surface coating or treatment.
- SGM** Soft Gasket Material (including fiber, beater addition, paper, flexible graphite and cut rubber sheet) – A die-cut soft material that compresses to conform to the joint and create a seal. The gasket may additionally be treated with printed beads, surface coatings, sealing grommets, pressed beads, or saturants.
- Com** Composite – A gasket formed by combining one or more layers of a soft gasket material with one or more metallic layers. Layers may be mechanically or chemically bonded.
- FIPG** Formed-In-Place Gasket – See Section 2 for definition.
- CIPG** Cured-In-Place Gasket – See Section 2 for definition.
- IIP** Injected-In-Place – See Section 2 for definition.
- MIP** Molded-In-Place – See Section 2 for definition.
- RTV** Room Temperature Vulcanizing, a curing mechanism, e.g., for RTV Elastomers – see also Section 4 RTV Elastomer sealants.
- Cu** Copper
- GEC** Global Engineering Center
- T-joint** Area where two joints meet – See also Section 6.2.

11. BIBLIOGRAPHY

- ¹ Klöpfer M., Jäckle, M., Lechner G, Universität Stuttgart, Institut für Maschinenelemente: Deckeldichtungen. Abschlußbericht 152/III, FVA-Forschungsheft-Nr. 463, Frankfurt: Forschungsvereinigung Antriebstechnik e.V., 1995
- ² Kreuzer R.: MAE.0001 – Comparison of Anaerobic (518) and Silicone (5699) as Gasketing Materials. MRD 94-04 June 17, 1994.
- ³ Prediger B., Kleiner F.: MAE.0021 – Blowout Behavior of Silicones. MRD 95-01 January 31, 1995.
- ⁴ Ritter K-H., Schmatz T.: Design Instruction RTV Silicone – Sealant. September 1996.
- ⁵ Ritter, K-H., Clauss, R.: The New Challenge for Sealant Supplier – A Partnership with the Automotive Industry. SAE 960212, Society of Automotive Engineers, Inc., Warrendale, PA, 1996.
- ⁶ Kreuzer R.: MNA.0436 – Jaguar Engine AJ30/31. MRD 96-01 April 9, 1996.
- ⁷ Kreuzer R., McClelland B., Garnich F.: MAE.0420 – Design Guidelines for Gasketing Applications. MRD 96-03 July 17, 1996.
- ⁸ Kleiner F.: MNA.0006 – Anaerobic Solution for a Bedplate Application. MRD 96-04 August 23, 1996.
- ⁹ Kreuzer R.: MTP.0497 – Gasketing Fatigue Test with 5900. MRD 96-07 December 13, 1996.
- ¹⁰ Ritter, K-H.: Design Guidelines and Concepts for Zero-Gap Bedplate Sealing. SAE 1999-01-0593, Society of Automotive Engineers, Inc., Warrendale, PA.
- ¹¹ Kreuzer R.: MAE.0019 – Comparative Testing of Gasketing Materials. Reports MRD 97-03 May 16, 1997, MRD 98-04 July 6, 1998, MRD 99-04 May 18, 1999.
- ¹² Kleiner F.: MAE.0623 – Surface Roughness Investigation. MRD 99-09 July 31, 1999.
- ¹³ Kreuzer R., Romanos G.: Zuverlässigkeit von Flächendichtungen auf Basis von Flüssigdichtmitteln unter dynamischer Beanspruchung. VDI Berichte Nr. 1579, 2000.
- ¹⁴ Kreuzer R.: MAE.0747 – Comparative Fatigue Testing. MRD 00-04 May 18, 2000.
- ¹⁵ Kreuzer R.: MDP.1020 – Ford RTV Key Life Test. MRD 00-05 June 5, 2000.

¹⁶ Kreuzer R.: MAE.0749 – FEA Model of a Sealed Joint. MRD 00-21 December 11, 2000.

¹⁷ Kreuzer R.: MAE.5017 – Comparative Fatigue Testing. MRD 01-01 January 16, 2001.

¹⁸ Kreuzer R.: MAE.5041 – Fatigue Tests at Gasket Test Rig 2.
MRD 01-06 August 21, 2001.

¹⁹ Kreuzer R.: MDP.5045 – Ford-KLT 5970 Investigation.
MRD 01-05 September 24, 2001.

²⁰ Schmatz T.: Guideline to Seal the T-Joint. September 2001.

²¹ Schmatz T.: MDP.0722 – T-Joint Investigation for Ford. MRD 01-07 October 18, 2001.

²² Kreuzer R.: MAE.5040 – Adhesive Layer Thickness. MRD 02-03 February 4, 2002.

²³ Kreuzer R.: MAE.0748 – Gearbox Fatigue Testing. MRD 02-05 July 1, 2002.

²⁴ Kreuzer R.: MAE.5067 – Component Fatigue Testing – Gearbox. MRD 03-02 January 20, 2003.

²⁵ Kirchberger P.: Ford Puma T-Joint. MRD 03-04 February 27, 2003.

²⁶ Schmatz T.: MDP.0905 – Next Generation RTV. MRD 03-06 March 21, 2003.

²⁷ Becher J.: MAE.5068 – Adhesive Joint Behavior. MRD 03-07 March 20, 2003

²⁸ Loctite Worldwide Design Handbook. 2nd Edition 1998

Release:

Version: 1.4

Location: Rocky Hill, Connecticut

Date: June, 2018

Authors:

Renate Kreuzer, Henkel GEC, Engineering Scientist

Thomas Schmatz, Henkel GEC, Manager Transportation Engineering



Henkel Corporation
Engineering Adhesives
www.na.henkel-adhesives.com/gasketing
www.loctite.com

U.S.A.
Henkel Corporation
Engineering Adhesives
One Henkel Way
Rocky Hill, Connecticut 06067
Tel: 1.800.LOCTITE (562.8483)
Tel: 860.571.5100
Fax: 860.571.5465

Canada
Henkel Canada Corporation
Engineering Adhesives
2515 Meadowpine Blvd.
Mississauga, Ontario L5N 6C3
Tel: 1.800.263.5043 (within Canada)
Tel: 905.814.6511
Fax: 905.814.5391

The data contained herein are intended as reference only. Please contact Henkel for assistance and recommendation on specifications for these products.

All marks used are trademarks and/or registered trademarks of Henkel and its affiliates in the U.S., Germany and elsewhere.
© 2018 Henkel Corporation. All rights reserved. 1149480/LT-8400 (08/2018)