

LOCTITE[®]
BONDERITE[®]
TECHNOMELT[®]
TEROSON[®]
AQUENCE[®]

Innovative Solutions for Electric Motors

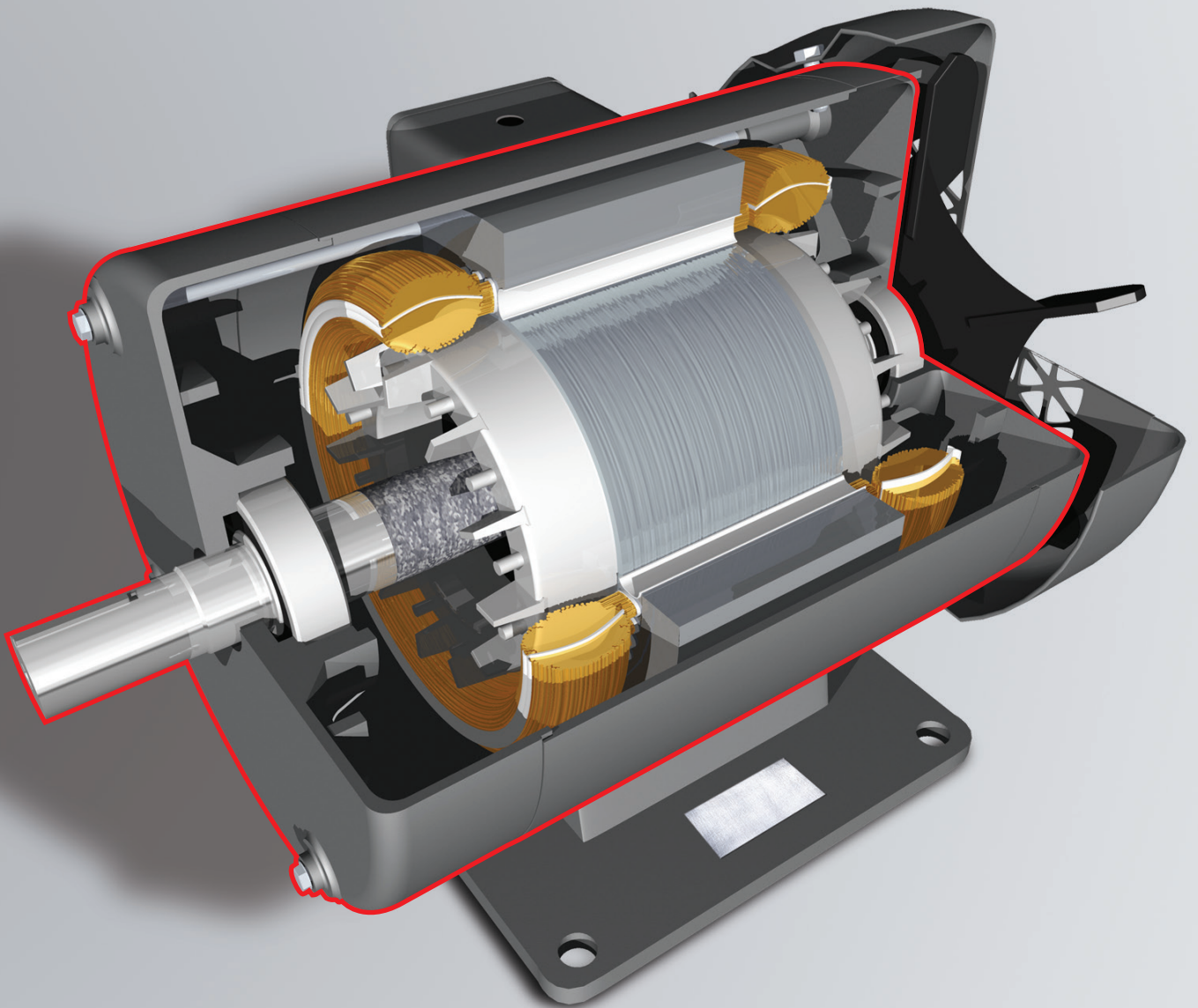

Solutions for Electric Motors

As an electric motors manufacturer, you face demanding market requirements for increased durability, lower cost and greater motor efficiency. Henkel, the leading solution provider for adhesives, sealants and functional coatings, offers expertise throughout the value chain, as well as innovative solutions that provide maximum reliability and cost-effective production.

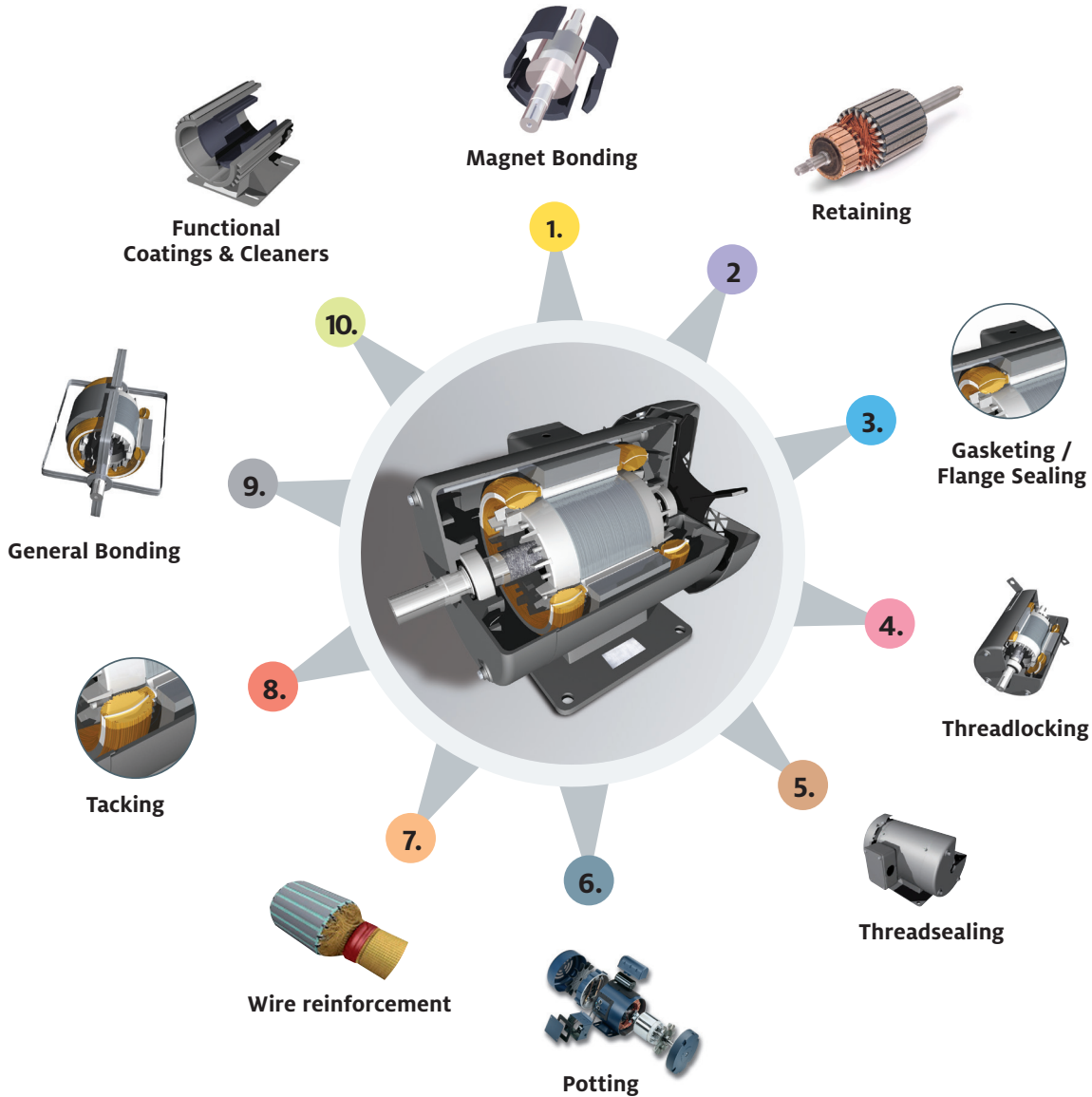

CUSTOMER PARTNERSHIP

From design and product development to the final manufacturing process, Henkel adhesive specialists provide you with technical support and recommendations to meet your design challenges.

TECHNOLOGY LEADERSHIP

Complete product portfolio recognized in manufacturing and maintenance for delivering superior performance.

INDUSTRY KNOW-HOW

We bring a wealth of expertise and experience to our customers to improve efficiency, product reliability and overall costs.



1.

2.

3.

4.

5.

6.

7.

8.

9.

10.

1. Magnet Bonding

- Replace mechanical fasteners to reduce parts and decrease costs
- Fill gaps (eg. between stator and magnet and rotor to magnet) for lower tolerances
- Improve resistance to impact and vibration
- Improve adhesion to all magnetic materials
- Simplify automated assembly
- Reduce vibration and noise
- Improve high temperature resistance

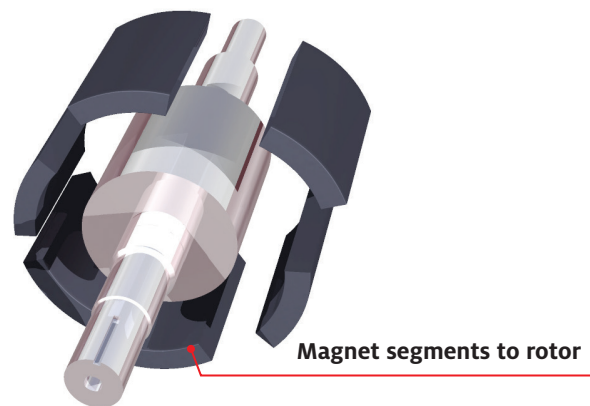
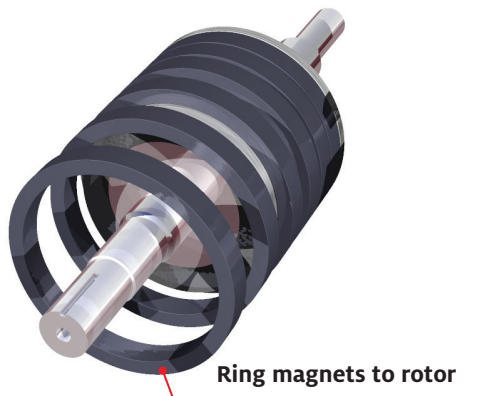

2. Retaining

- Increase torque load transfer of existing designs
- Provide even distribution of load and stresses
- Prevent corrosion from fretting or environmental exposures
- Reduce tolerances, overall size and weight while maintaining equal performance
- Eliminate backlash/wallowing in keyways and splines

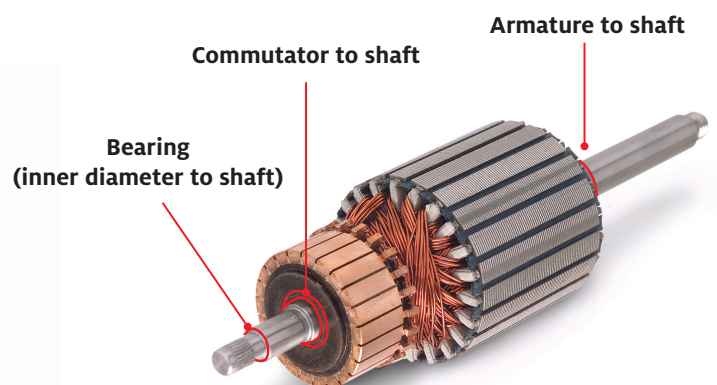
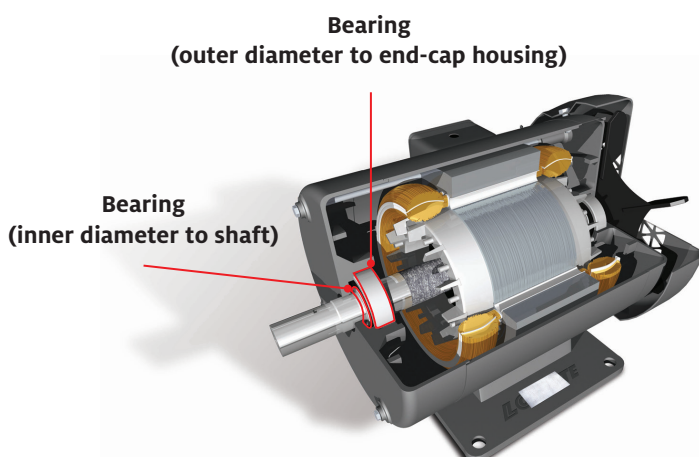



3. Gasketing / Flange Sealing

- Eliminate inventory of multiple gasket and o-ring sizes and types
- Reach higher IP (Ingress Protection) rating of motor
- Reduce noise and vibration
- Avoid gasket creep and relaxation
- Reduce material cost compared to cut gasket materials
- Add to structural stiffness / allows light weighting

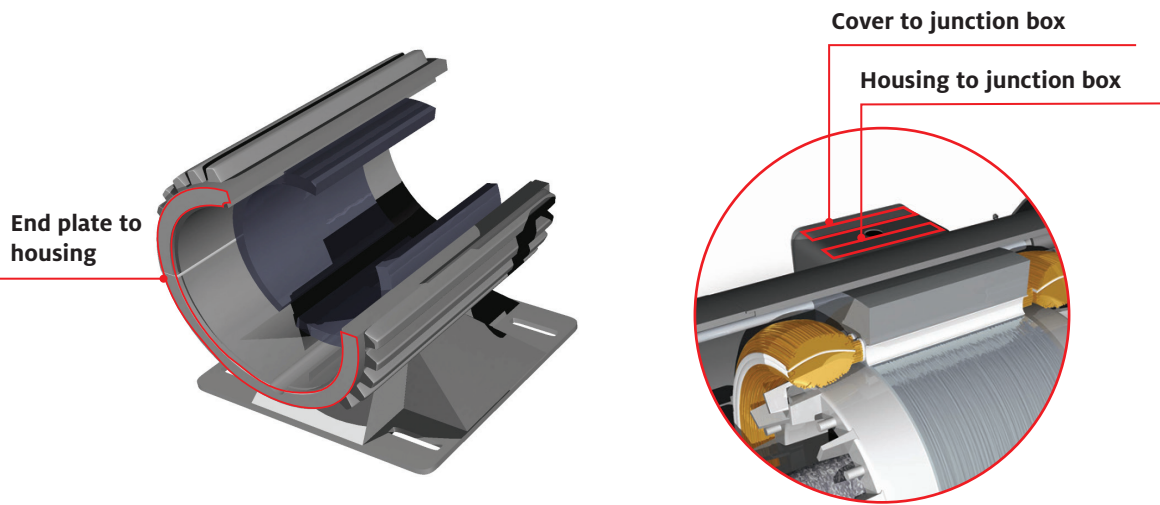

4. Threadlocking

- Maintain proper clamp load over life of motor
- Eliminate bolt loosening from vibration or thermal cycling stresses
- Seal threads from liquids and gasses
- Prevent corrosion
- Replace more costly or less effective mechanical locking devices

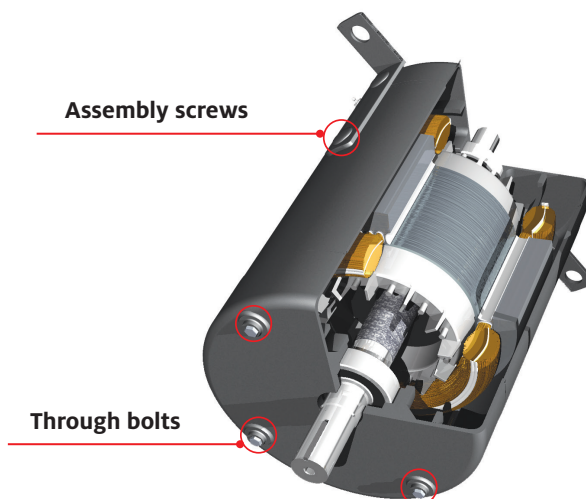

1.

2.

3.

4.

5.

6.

7.

8.

9.

10.

5. Threadsealing

- Seal threads from liquids and gasses
- Eliminate inventory of multiple seals and o-ring sizes and types
- Prevent corrosion
- Eliminate leaks from vibrational loosening
- Excellent chemical resistance against industrial liquids and gasses

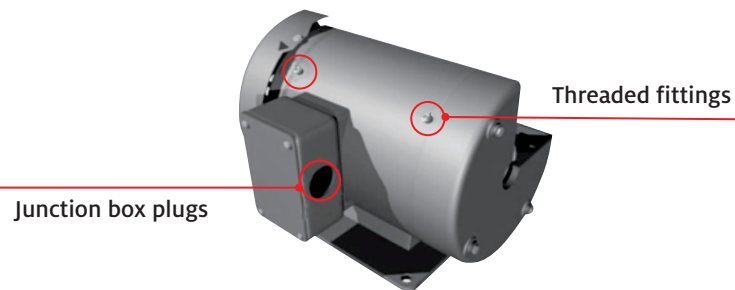

6. Potting

- Encapsulate and insulate from environmental effects
- Protect components against impact, vibrations, thermal shocks, moisture and dust
- Prevent contamination and corrosion
- Improve heat dissipation
- Simplify process automation
- Improve reliability and life expectancy

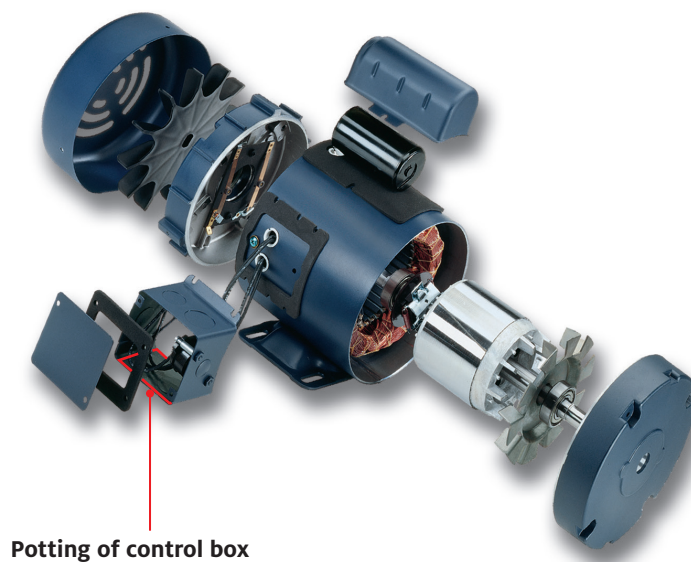



7. Wire Reinforcement / Electrical Connections

- Unitise wires and electrical connections
- Improve resistance to high loads such as centrifugal forces
- Protect wires from flexing fatigue
- Achieve higher rotation speeds
- Improve reliability and life expectancy

AC

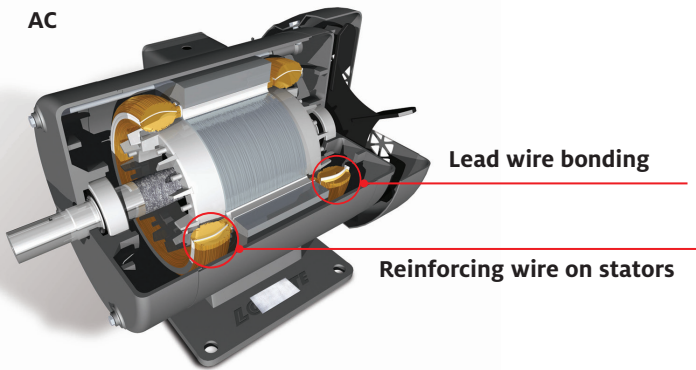

DC

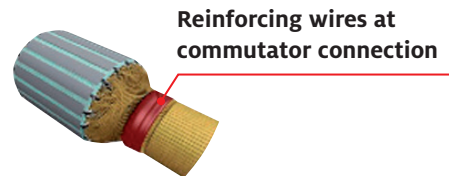

8. Tacking

- Position wires and insulation during manufacturing
- Prevent wire breakages due to vibration and during motor assembly and handling

Lead wire tacking on stators
and insulation to stator wires

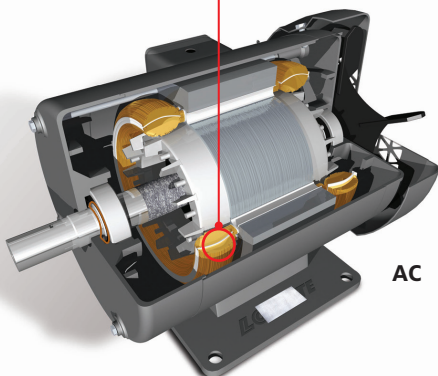

DC

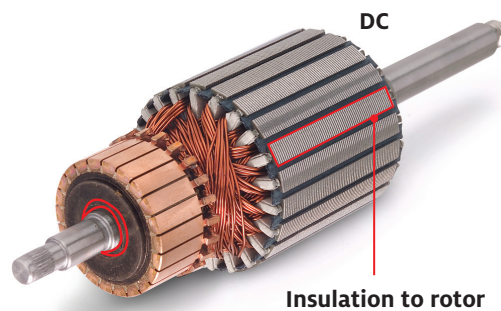

1.

2.

3.

4.

5.

6.

7.

8.

9.

10.

9. General Bonding

- Join and seal dissimilar materials, enabling use of new, improved and innovative materials
- Simplify design, reduce number of parts used
- Fill gaps, allowing wider tolerances
- Improve vibration resistance and reduce noise
- Reduce costs

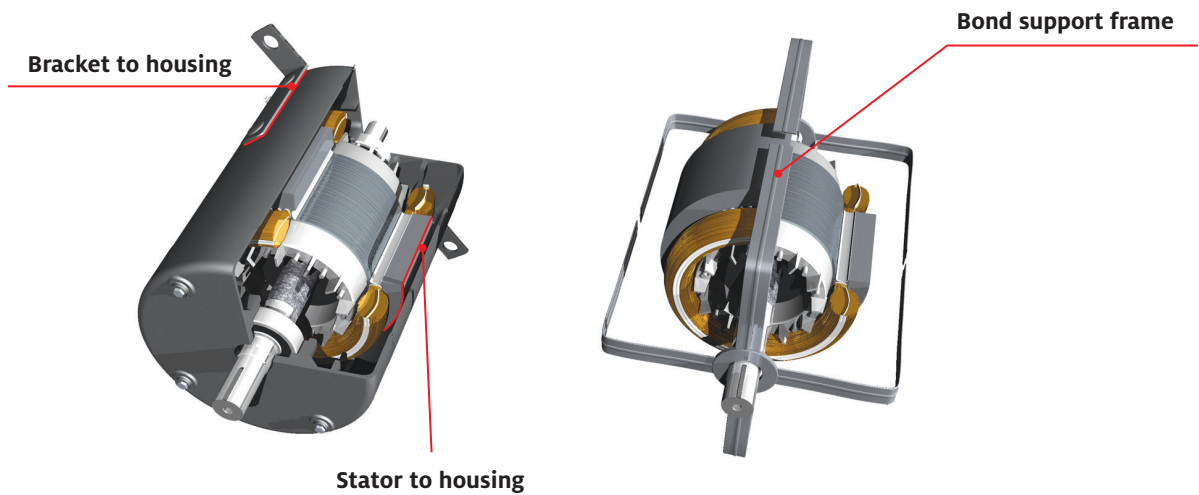

10. Functional Coatings & Cleaners

- Dramatically enhance coating adhesion
- Improve the long-term durability of the final finish
- Increase user safety and decrease environmental impact of your processes
- Reduce total processing costs

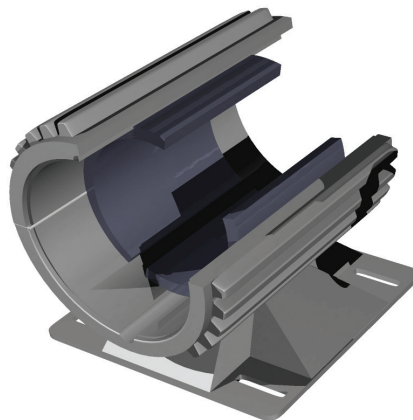

To learn more about LOCTITE solutions for electric motors, contact your Henkel representative or visit www.loctite.com

LOCTITE®
BONDERITE®
TECHNOMELT®
TEROSON®
AQUENCE®

Henkel Corporation
Engineering Adhesives
<http://www.henkel-adhesives.com>
www.loctite.com

U.S.A.
Henkel Corporation
Engineering Adhesives
One Henkel Way
Rocky Hill, Connecticut 06067
Tel: 1.800.LOCTITE (562.8483)
Tel: 860.571.5100
Fax: 860.571.5465

Canada
Henkel Canada Corporation
Engineering Adhesives
2515 Meadowpine Blvd.
Mississauga, Ontario L5N 6C3
Tel: 1.800.263.5043 (within Canada)
Tel: 905.814.6511
Fax: 905.814.5391