

LOCTITE®
BONDERITE®
TEROSON®

Innovative Solutions for Electric Motors

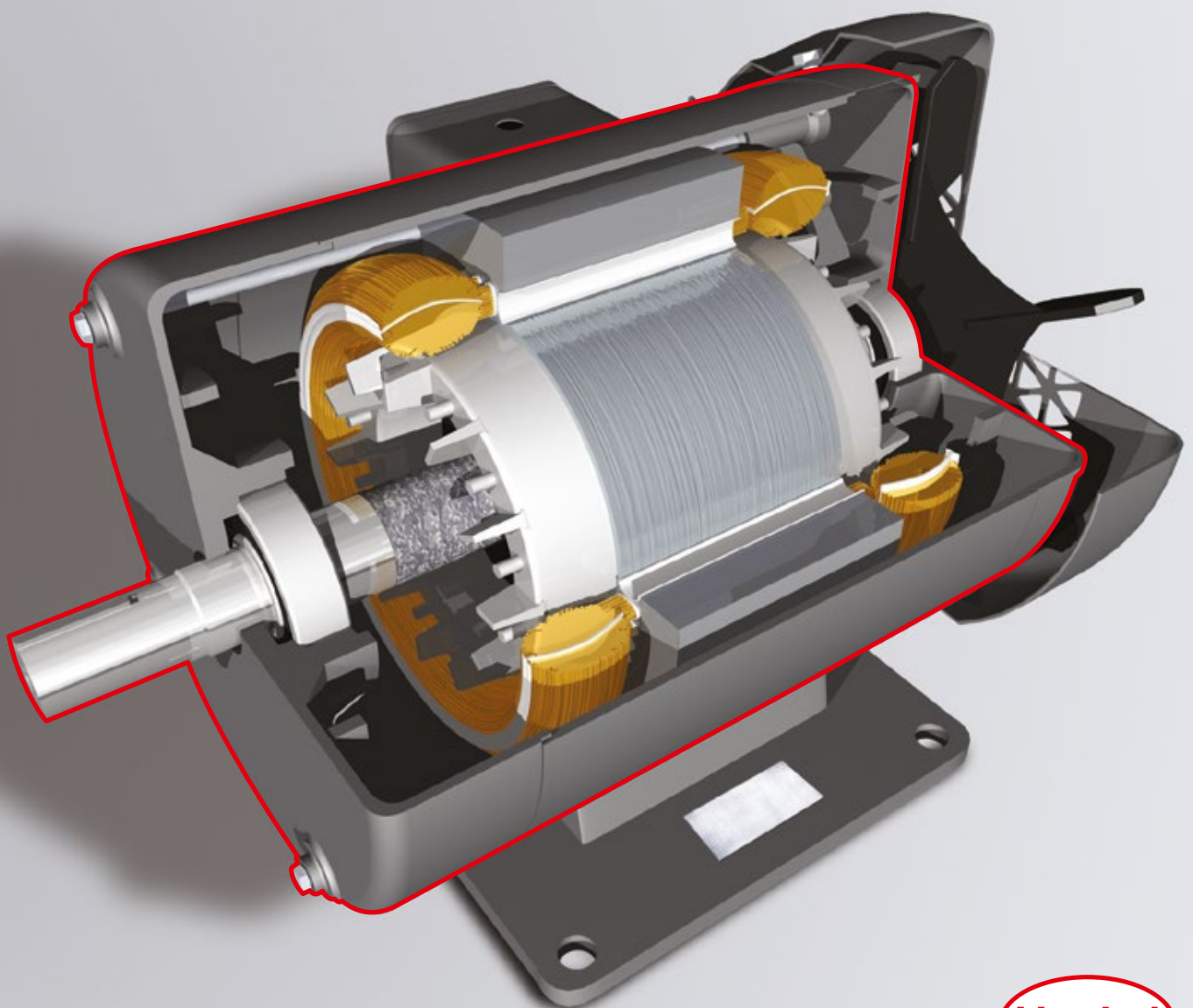

Henkel

Solutions for Electric Motors

As an electric motors manufacturer, you face demanding market requirements for increased product durability, greater motor efficiency and lower production costs. Henkel, the leading solution provider for adhesives, sealants and functional coatings, offers expertise throughout the value chain, as well as innovative solutions and dispensing options that provide maximum reliability and cost-effective production.

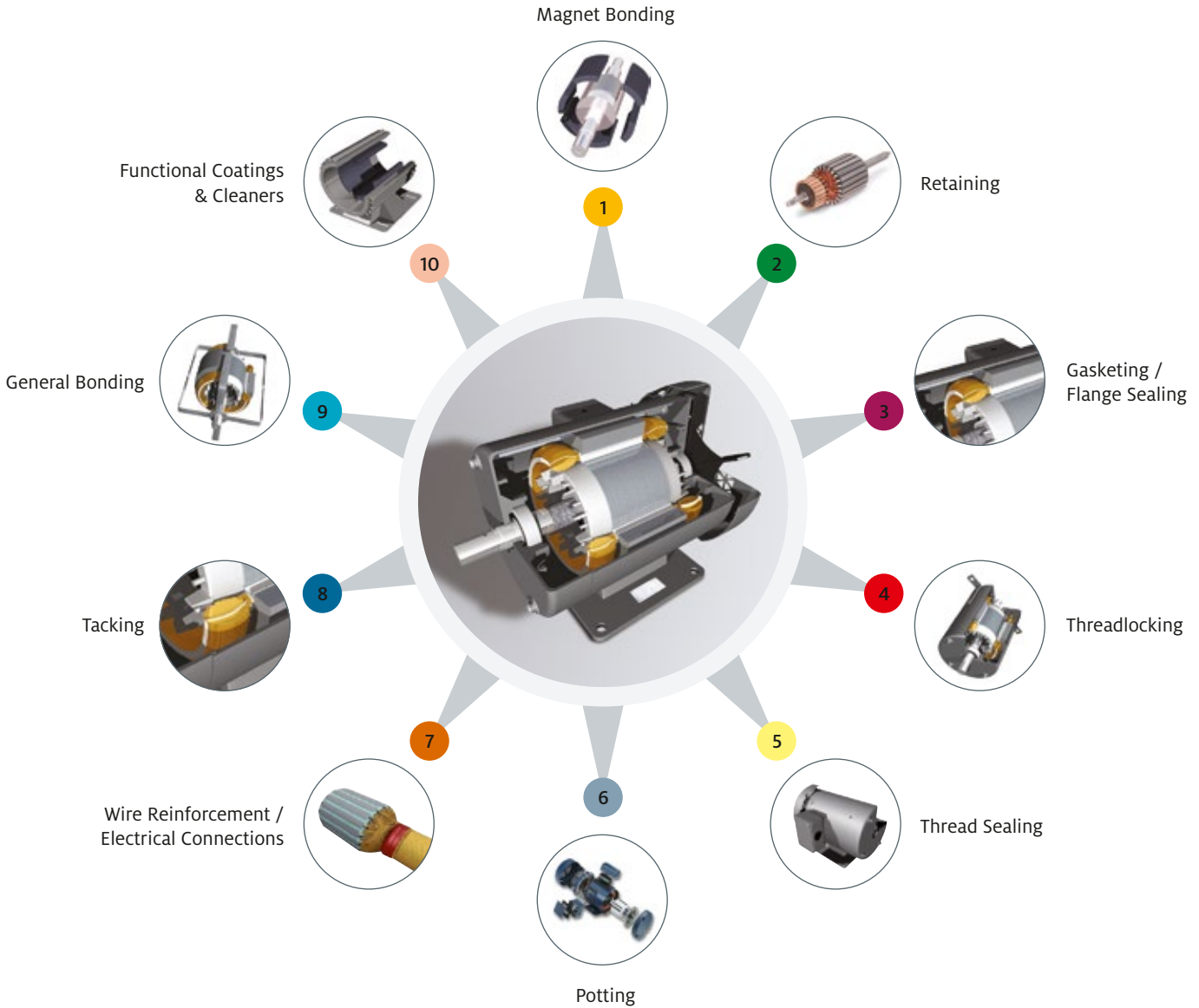

CUSTOMER PARTNERSHIP

From design and product development to the final manufacturing process, Henkel adhesive specialists provide you with technical support and recommendations to meet your design challenges.

TECHNOLOGY LEADERSHIP

Complete product portfolio recognized in manufacturing and maintenance for delivering exceptional performance.

INDUSTRY KNOW-HOW

We bring a wealth of expertise and experience to our customers to improve efficiency, product reliability and overall costs.





Ring magnets to rotor



Magnet segments to rotor

1 Magnet Bonding

- > Replace mechanical fasteners to reduce parts and decrease costs
- > Fill gaps (e.g. between stator and magnet and rotor to magnet) for lower tolerances
- > Improve resistance to impact and vibration
- > Improve adhesion to all magnetic materials
- > Simplify automated assembly
- > Reduce vibration and noise
- > Improve high temperature resistance

Bearing
(outer diameter to end-cap housing)



Bearing
(inner diameter to shaft)

2 Retaining

- > Increase torque load transfer of existing designs
- > Provide even distribution of load and stresses
- > Prevent corrosion from fretting or environmental exposures
- > Reduce tolerances, overall size and weight while maintaining equal performance
- > Eliminate backlash / wallowing in keyways and splines

Commutator to shaft Armature to shaft

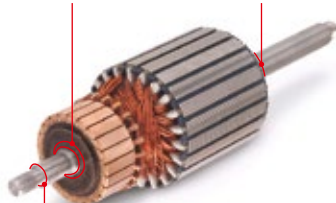

Bearing
(inner diameter to shaft)

End plate to housing

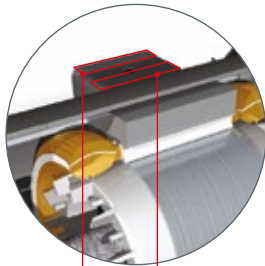

Housing to junction box

Cover to junction box

3 Gasketing / Flange Sealing

- > Eliminate inventory of multiple gasket and o-ring sizes and types
- > Reach higher IP (Ingress Protection) rating of motor
- > Reduce noise and vibration
- > Avoid gasket creep and relaxation
- > Reduce material cost compared to cut gasket materials
- > Add to structural stiffness / allow lightweighting

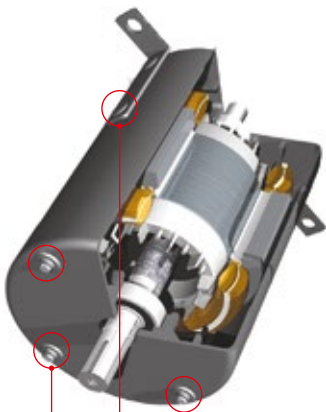

Assembly screws

Through bolts

4 Threadlocking

- > Maintain proper clamp load over life of motor
- > Eliminate bolt loosening from vibration or thermal cycling stresses
- > Seal threads from liquids and gasses
- > Prevent corrosion
- > Replace more costly or less effective mechanical locking devices

5 Thread Sealing

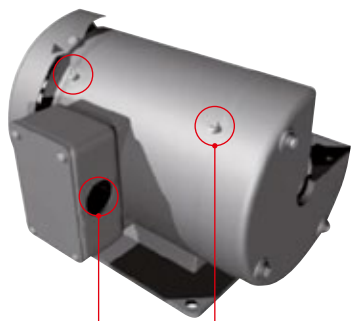

Threaded fittings

Junction box plugs

- > Seal threads from liquids and gasses
- > Eliminate inventory of multiple seals and o-ring sizes and types
- > Prevent corrosion
- > Eliminate leaks from vibrational loosening
- > Excellent chemical resistance against industrial liquids and gasses

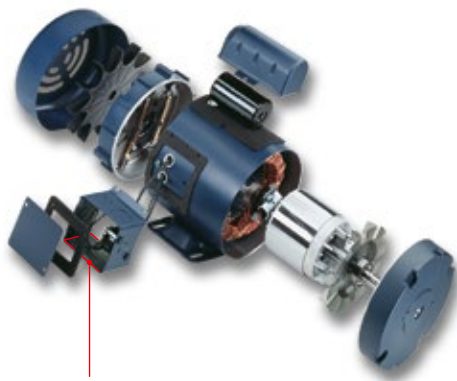

Potting of control box

6 Potting

- > Encapsulate and insulate from environmental effects
- > Protect components against impact, vibrations, thermal shocks, moisture and dust
- > Prevent contamination and corrosion
- > Improve heat dissipation
- > Simplify process automation
- > Improve reliability and life expectancy

Henkel offers various dispensing and curing equipment that can be easily integrated into your manufacturing process. For additional information, contact your Henkel representative or visit www.henkel-adhesives.it



AC*

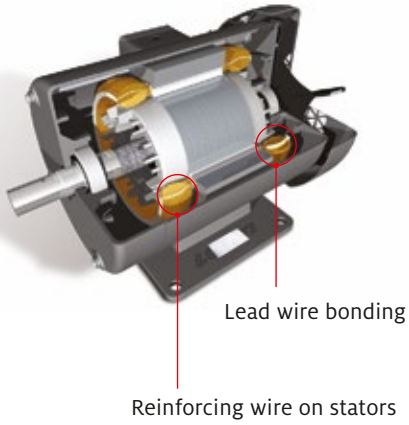

7 Wire Reinforcement / Electrical Connections

- > Unitise wires and electrical connections
- > Improve resistance to high loads such as centrifugal forces
- > Protect wires from flexing fatigue
- > Achieve higher rotation speeds
- > Improve reliability and life expectancy

DC**

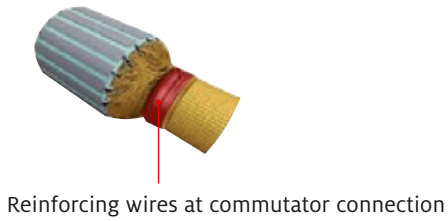

AC*

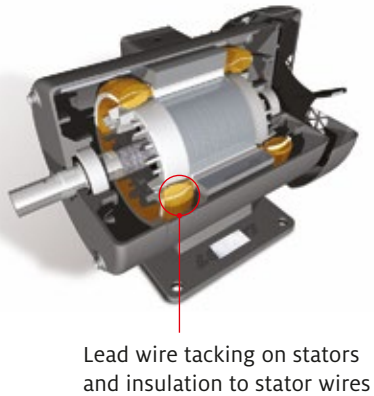

8 Tacking

- > Position wires and insulation during manufacturing
- > Prevent wire breakages due to vibration and during motor assembly and handling

DC**

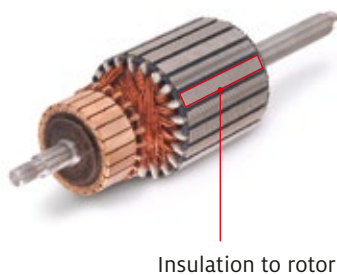

Bracket to housing

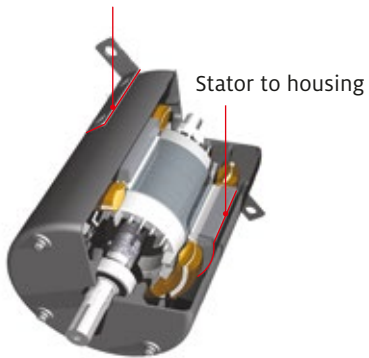

Stator to housing

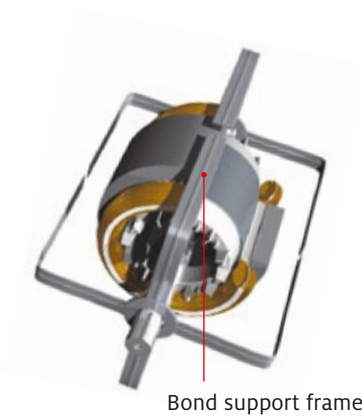

Bond support frame

9 General Bonding

- > Join and seal dissimilar materials, enabling use of new, improved and innovative materials
- > Simplify design, reduce number of parts used
- > Fill gaps, allowing wider tolerances
- > Improve vibration resistance and reduce noise
- > Reduce costs



10 Functional Coatings & Cleaners

- > Dramatically enhance coating adhesion
- > Improve the long-term durability of the final finish
- > Increase user safety and decrease environmental impact of your processes
- > Reduce total processing costs

To learn more about LOCTITE solutions for electric motors and equipment options, please visit www.henkel-adhesives.it

LOCTITE®
BONDERITE®
TECHNOMELT®
TEROSON®
AQUENCE®

Henkel Italia S.r.l.

Via C. Amoretti, 78
20157 Milano (MI)

Tel.: (+39) 02 35792 963
Fax: (+39) 02 35792 940
www.henkel.it
www.henkel-adhesives.it

The data contained herein are intended as reference only. Please contact Henkel Technical Support Group for assistance and recommendation on specifications for these products.

Except as otherwise noted, all marks used above in this printed material are trademarks and/or registered trademarks of Henkel and/or its affiliates in US, Germany, and elsewhere. © Henkel AG & Co. KGaA, 2016