



LOCTITE®

WORLDWIDE

EQUIPMENT

OPERATION MANUAL



Hand-held Applicator

97111

97112

97116

GLOBAL AVAILABILITY

GLOBAL SERVICE

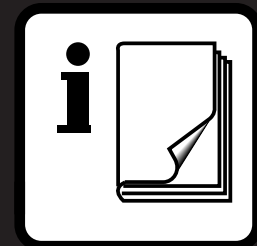



HAND-HELD APPLICATOR

97111/97112/97116

AN INTEGRATION OF ADHESIVE AND EQUIPMENT TECHNOLOGY

FEATURES

- Ergonomically designed for hand comfort and application control
- Low actuation force to reduce hand fatigue
- Designed with a suck-back feature for dispensing accuracy and control
- Adaptable to optional reservoirs based on product package
- Dispenses Loctite® innovative chemistries up to 50,000 cPs
- Worldwide Availability
- Worldwide Service
- Application support for integrating both the adhesive and equipment interface

For additional information on Loctite Worldwide Adhesives and Equipment, please contact your local Loctite representative for a copy of the Loctite Design Handbook.

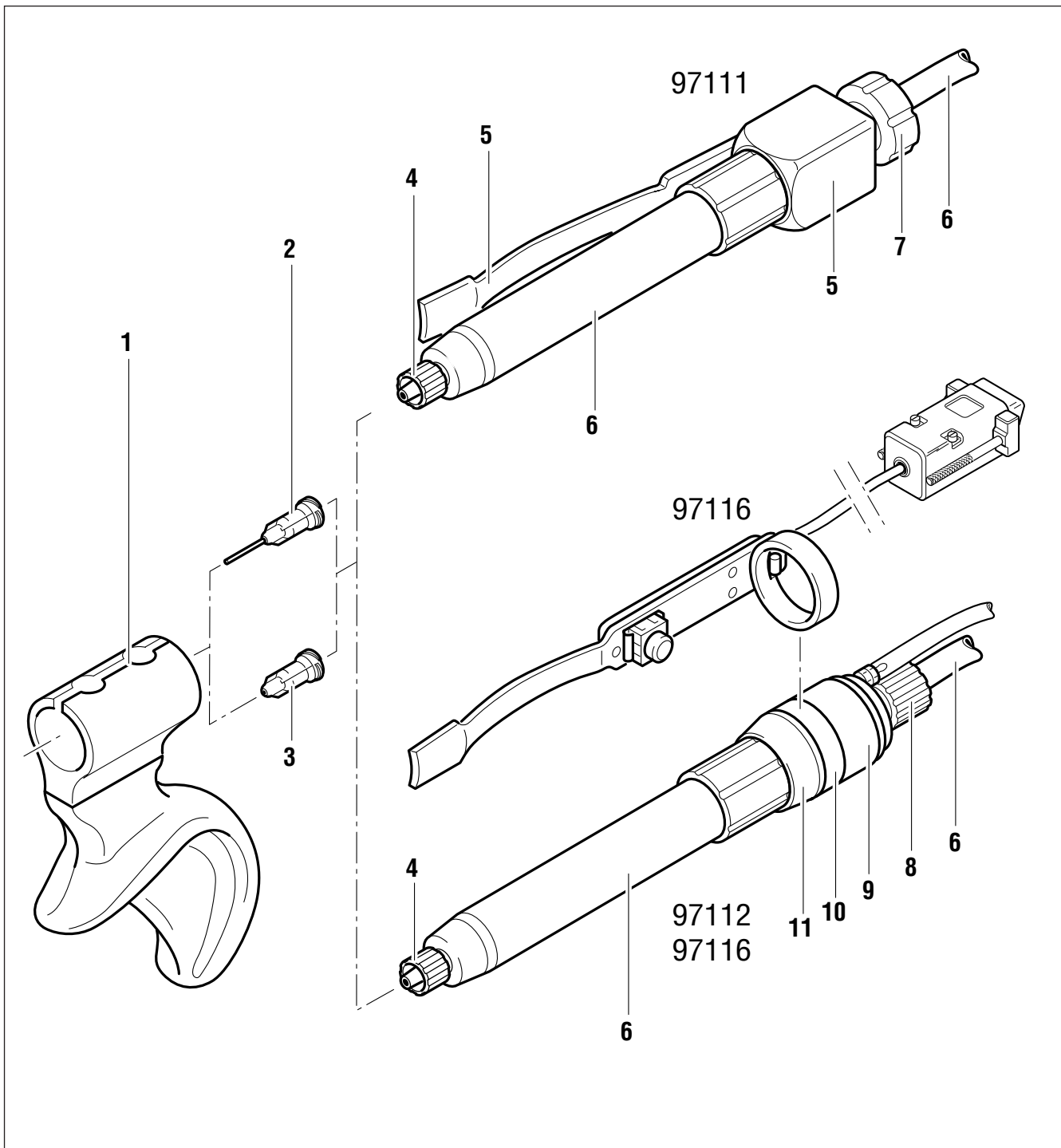

97105

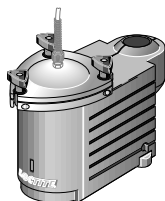

97107

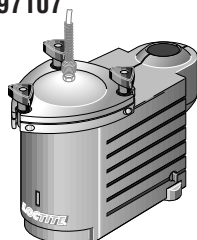

97109

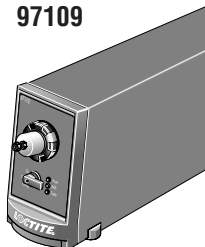

Reservoir Options

97106

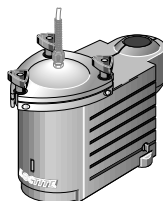

97108

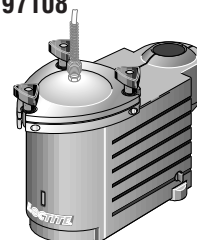

97110

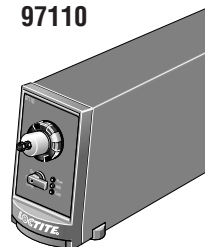

Reservoir Options



97101



Manual Controller

97102



Semi-Automatic Controller

97103 + 97204



Automatic Controller

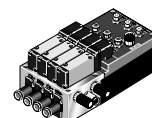

97111



Hand-held Applicator

97112



97116



97113
97114

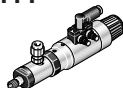

97113
97114

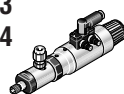

Dispense Valve

97113
97114

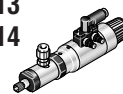

Dispense Valve

97115

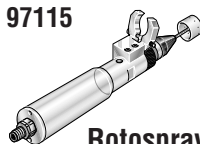

Rotospray

97115

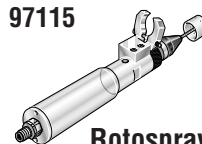

Rotospray

97118
97119

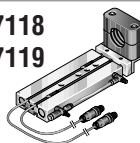

Advancing Slide

97118
97119

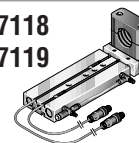

Advancing Slide

97006



Syringe System

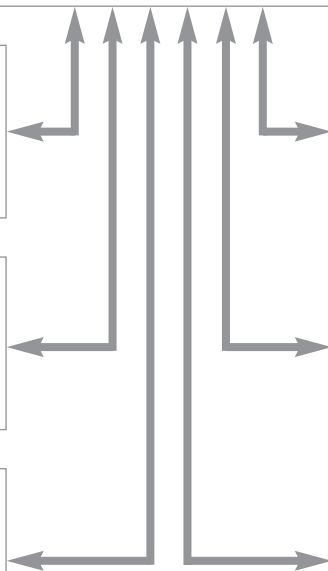

Contents

	Page No.
1 Please observe the following	
1.1 Emphasized Sections	1
1.2 Items Supplied	1
1.3 For Your Safety	2
1.4 Usage	2
2 Description	
2.1 Operating Elements and Connections	2, 3
2.2 Theory of Operations	3
3 Technical Data	4
4 Installation	
4.1 Connecting the Unit	5, 6
4.2 Mounting the Hand Grip	7
5 Dispensing	
5.1 First Operation	7
5.1.1 Priming the Hand-held Applicator	7
5.1.2 Adjusting the Dispensed Quantity	8
5.1.2.1 Adjusting the Suck-Back Effect (Piston Stroke)	8
5.1.2.2 Mounting the Feedtube Adapter	9
5.2 Shutdown	10
5.3 Returning to Operation	10
5.4 Valve Assembly Replacement	10
6 Troubleshooting	11
7 Accessories and Spare Parts	12
8 Equipment Warranty	13

1.1 Emphasized Sections

Warning!



Refers to safety regulations and requires safety measures that protect the operator or other persons from injury.

Caution!



Emphasizes what must be done or avoided so that the unit or other property is not damaged.

Notice



Gives recommendations for better handling of the unit during operation or adjustment as well as for service activities.

The numbers printed in bold in the text refer to the corresponding position numbers in the illustration on the front fold-out page (see Section 2.1).

Instruction steps in the illustrations are indicated with arrows.

When several instruction steps are indicated in an illustration, the shading of the arrow has the following meaning:

Black arrow = 1st step

Grey arrow = 2nd step

White arrow = 3rd step

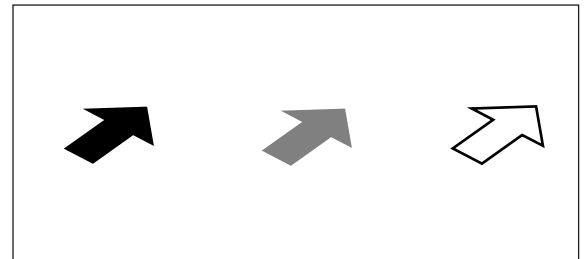

1.2 Items Supplied

1 Hand-held Applicator 97111 (mechanical) or
Hand-held Applicator 97112 (pneumatic footswitch) or
Hand-held Applicator 97116 (fingerswitched);

1 Pencil Holder;

Accessory Items;

1 Needle Kit;

1 Instruction Manual.



As a result of technical development, the illustrations and descriptions in this instruction manual can deviate in detail from the actual unit delivered.

1

Please observe the following

1.3 For Your Safety



For safe and successful operation of the unit, read these instructions completely. If the instructions are not observed, the manufacturer can assume no responsibility.

- Observe general safety regulations for the handling of chemicals!
- Observe manufacturer's instructions! Request a safety data sheet for the product used!
- When working with pressurized air, wear protective glasses!

1.4 Usage

The Hand-held Applicators are suitable for dispensing Loctite® products in a manual or semi-automatic process.

This ergonomically designed applicator provides hand comfort and application control to eliminate hand fatigue and improve dispensing accuracy.

The applicators can be used in a hand-held fashion or mounted in a stationary manner that allows easy production line integration for fulfilling your dispensing needs.

Loctite provides a selection of product reservoirs that could be used with the various Hand-held applicators that are available.

2

Description

2.1 Operating Elements and Connections



- Fold out the illustration inside the front cover!

97111

- 1 Pistol grip
- 2 Dispensing needle
- 3 Luer-Lok tip cap
- 4 Luer-Lok adapter
- 5 Manual actuator assembly with trigger lever
- 6 Valve assembly with 6.3 mm product feedline
- 7 Adjustment knob (for the stroke of the shutoff piston)

97112 / 97116

- 1 Pistol grip
- 2 Dispensing needle
- 3 Luer-Lok tip cap
- 4 Luer-Lok adapter
- 5 Manual actuator assembly with trigger lever
- 6 Valve assembly with 6.3 mm product feedline
- 7 Adjustment knob (for the stroke of the shutoff piston) (97111 only)
- 8 Adjustment knob (for the stroke of the shutoff piston) (97112, 97116)
- 9 Pneumatic actuator assembly with pressurized air connection
- 10 Spacer ring (97112 only)
Holder ring with finger switch (97116 only)
- 11 Attachment ring

2.2 Theory of Operation

An uncovered bottle of Loctite® product is placed directly into the reservoir and the reservoir lid is clamped in place. The reservoir is then pressurized from a Loctite Controller using clean, filtered dry air. Air within the reservoir will push down on the liquid in the bottle and force it through the product feedline to the dispense shutoff valve.

The amount of product dispensed is controlled by three main factors:

- Amount of pressure in the reservoir.
- Length of time the shutoff valve remains open.
- Dispensing needle size.

97111

The opening of the Hand-held Applicator 97111 takes place manually by actuating the trigger lever.

97112

The opening of the Hand-held Applicator 97112 is pneumatically controlled. The start is initiated with the foot switch.

97116

The opening of the Hand-held Applicator 97116 is pneumatically controlled. The start is initiated with the finger switch.

97111 / 97112 / 97116

The shutting off of all hand-held applicators takes place mechanically by means of the spring return of the shutoff piston to the rest position. A negative pressure (suck-back effect) is thereby produced in the valve assembly 6 that prevents the product from continuing to run or drip out of the dispensing needle 2. This suck-back effect (stroke of the shutoff piston) can be changed with the adjustment knob 7 or 8.



With the changing of the piston stroke, the dispensed quantity is also changed.

Pneumatic supply 97112 / 97116

max 6.8 bar (max 100 psi)
min. 4.08 bar (min. 60 psi)Quality
If the required quality is not achieved,
install a LOCTITE®-filter regulator.

Filtered 10 µm, oilfree, non-condensing

Weight pistol grip

0.115 kg /4 oz.

Weight 97111 / 97112 / 97116

0.100 kg (3.5 oz.) / 0.140 kg (4.9 oz.) /
0.340 kg (11.96 oz.)

Dimensions

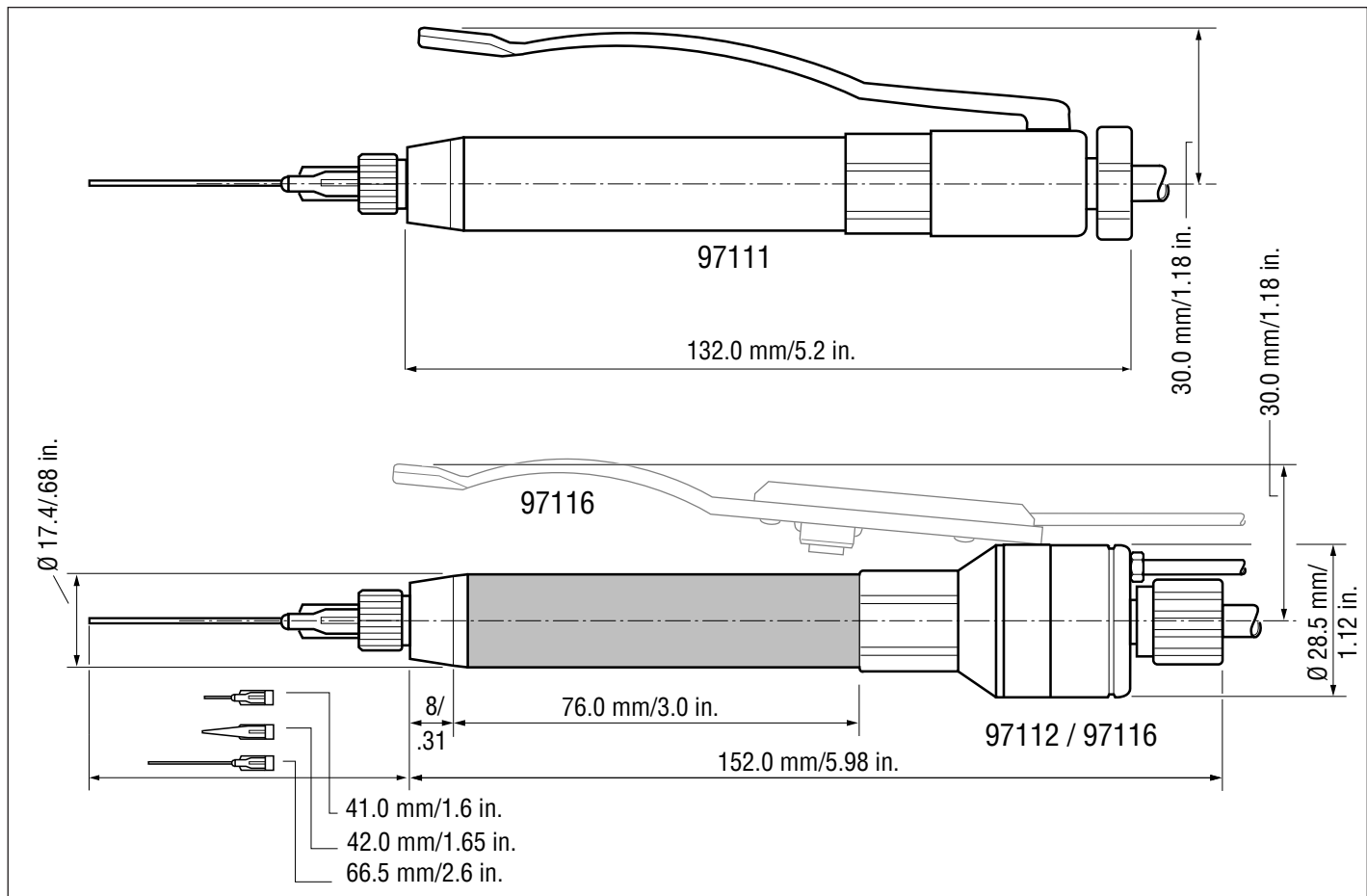

4.1 Connecting the Unit

Connecting to the Product Reservoir

A) .5 Liter
#97105/#97106

2 Liter
#97107/#97108

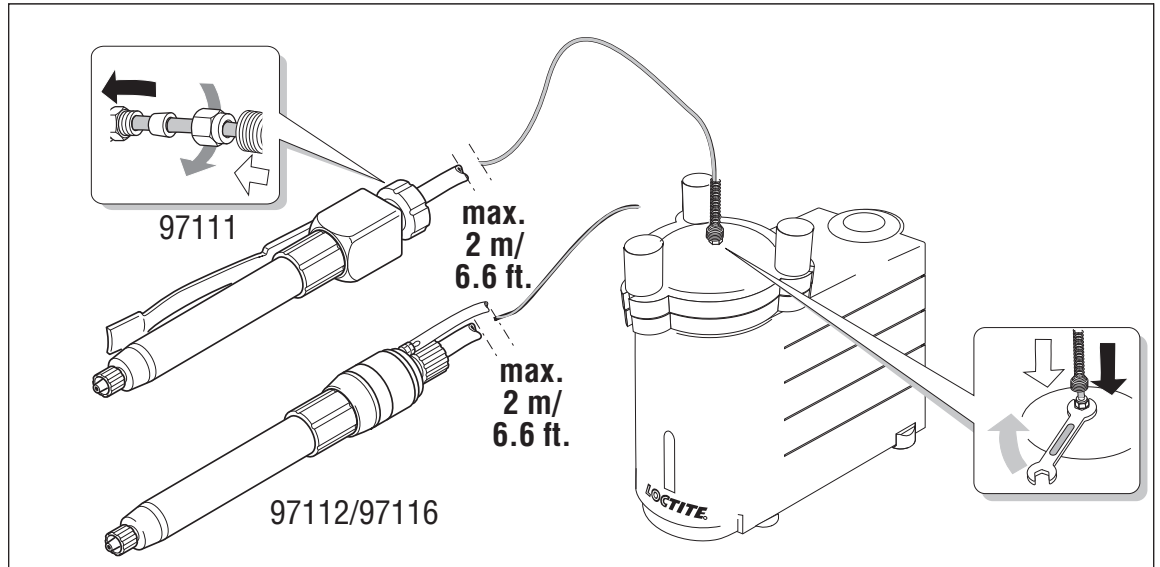

B) 300 ml
Cartridge
Reservoir
#97109/#97110

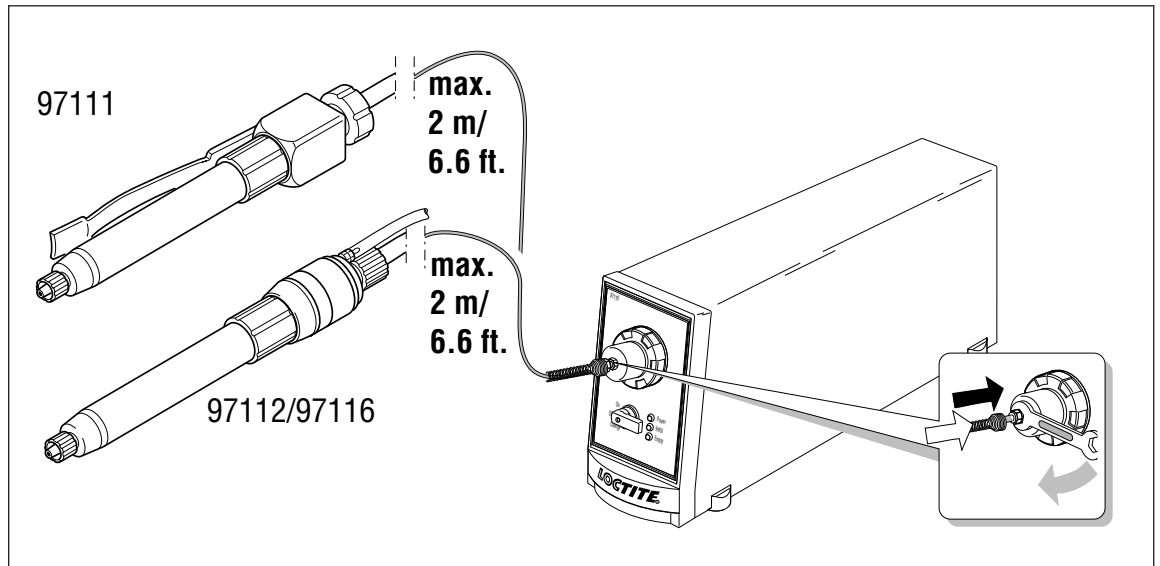

Connecting to the Semi-Automatic Controller (97112 or 97116 only)

C) Semi-Automatic Controller #97102

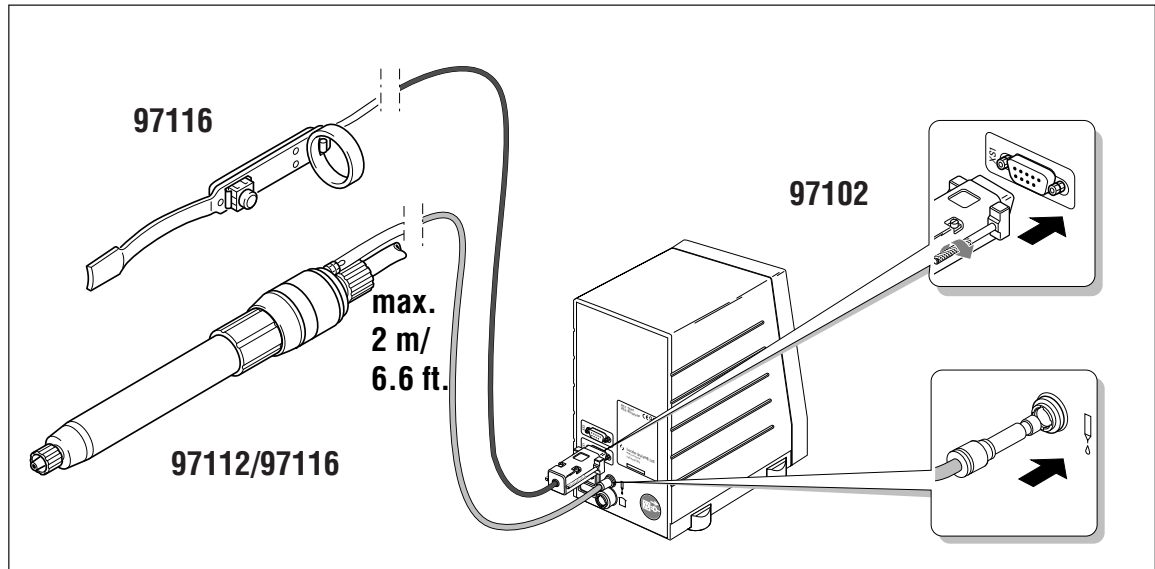

4

Installation

4.2 Mounting the Pistol Grip

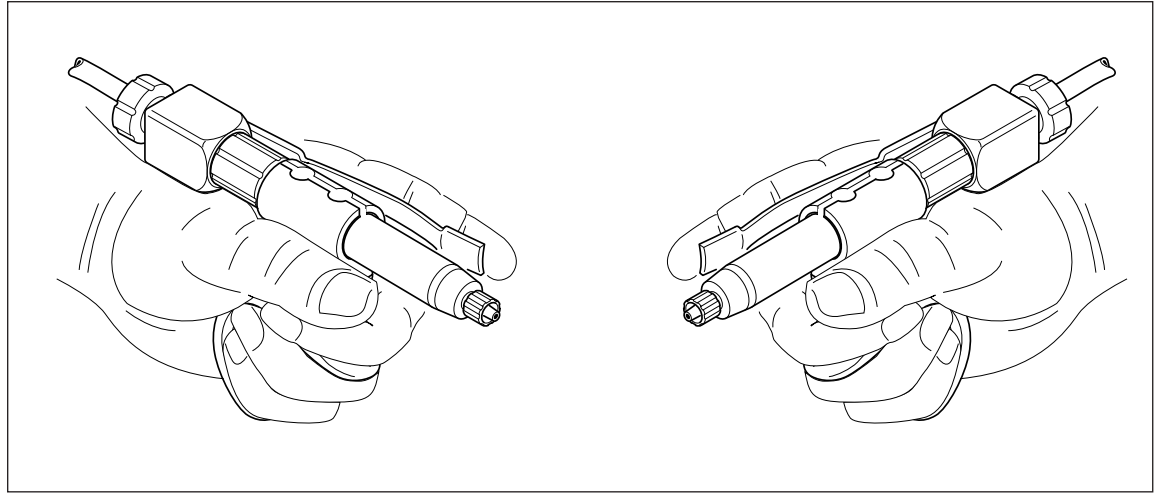

5

Dispensing

5.1 First Operation

5.1.1 Priming the Hand-held Applicator



To avoid air bubbles during dispensing, the product line must be filled and then purged of air.



- Place a container under the dispensing valve since the product will flow out.
- To fill the product line, hold the dispensing valve slanted upward so that no air will be trapped inside the valve chamber.
- Slide the silicone tubing provided over the dispensing needle.

97111

- Perform the filling of the product line according to the operating instructions of the LOCTITE® Manual Controller 97101.

97112 / 97116

- Perform the filling of the product line according to the operating instructions of the LOCTITE Controller 97102.

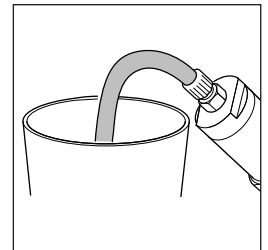

5.1.2 Adjusting the Dispensed Quantity



Before the dispensing quantity is adjusted, the stroke of the shutoff piston should be adjusted on the dispensing valve. With the changing of the piston stroke, the dispensed quantity is also changed for the same dispensing pressure.

5.1.2.1 Adjusting the Suck-Back Effect (Piston Stroke)

The piston stroke should be adjusted so that the product no longer drips out of the dispensing needle.



The product must not be sucked back too far since, when using cyanoacrylates, curing can occur in the product line and cause malfunction of the dispensing.

97111

- Manually press and release the trigger lever. When necessary, change the piston stroke with the adjustment knob 7:

Product drips:

- Turn the adjustment knob **counter clockwise**. The piston stroke (suck-back effect) is increased.

Product comes delayed after triggering:

- Turn the adjustment knob **clockwise**.

- Perform the adjustment of the dispensed quantity according to the operating instructions of the LOCTITE® Manual Controller 97101.

97112 / 97116

- Initiate a time controlled dispensing start (approx. 0.50 sec. long - see the operating instructions of the LOCTITE® Controller 97102. When necessary, change the piston stroke with the adjustment knob 8:

Product drips:

- Turn the adjustment knob **clockwise**. The piston stroke (suck-back effect) is increased.

Product comes delayed after a start:

- Turn the adjustment knob **counter clockwise**.

- Perform the adjustment of the dispensed quantity according to the operating instructions of the LOCTITE Controller 97102.

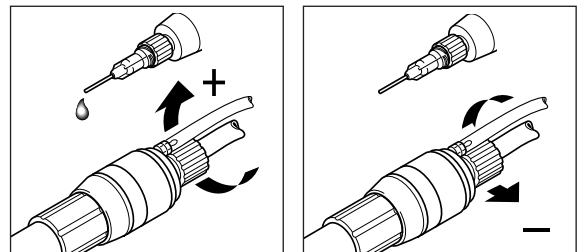
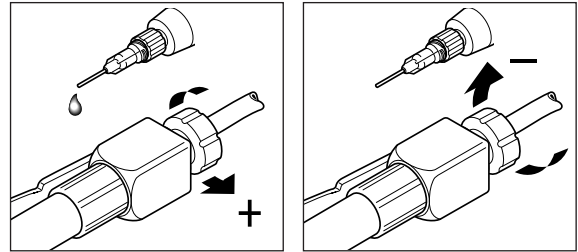

5.1.2.2 Mounting the Feedtube Adapter



For viscous products, a feedtube adapter with a 9.5 mm product feedline is available by ordering Part Number 97220.



When mounting the feedtube adapter, the product feedline must be cut off.
The contact of anaerobic products with the metal of a knife or other objects can cause curing and lead to malfunction of the dispensing.

- Cut off the product feedline evenly with a knife, cutters or hose cutter approximately 13 cm from dispensing valve.
- Slide the black caps on the 6.3 mm and 9.5 mm feedlines.

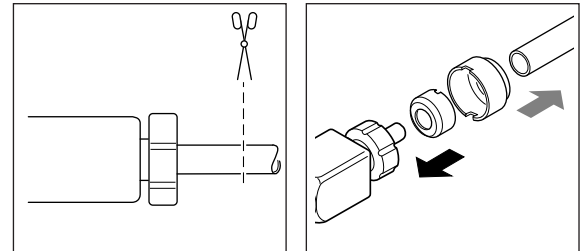

- Firmly insert the 6.3 mm and 9.5 mm product feedlines into the adapter. Press on the black caps as protection against unintentional loosening of the adapter.

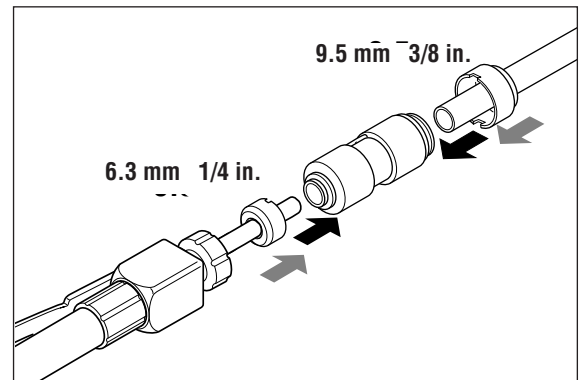

- Exchange the 6.3 mm reservoir threaded connector for a 9.5 mm connector.
- Fill the product line and adjust the dispensing quantity according to Sections 5.1.1 and 5.1.2

5.2 Shutdown

- To protect anaerobic products from curing, remove needle leaving Luer-Lok Adapter exposed to air.
- To protect all other product from curing, place a protective cap on the dispensing needle.
- If for some reason the product being dispensed changes, contact your local salesperson for the recommended procedures.

5.3 Returning to Operation

- Remove the protective cap from the dispensing needle.

Returning to Operation After Longer Periods of Non-use

- Remove the Luer-Lok tip cap.
- Perform the adjustment of the dispensing quantity according to Section 5.1.

5.4 Valve Assembly Replacement

Removing Valve Assembly

- Hold valve assembly in hand.
- While holding valve in hand, rotate Ring clockwise until valve assembly is disengaged from actuator assembly.
- Next, pull valve assembly including product feedline out through the actuator assembly.

Installing New Valve Assembly #97999

- First, insert the product feedline through the hole in the actuator assembly and pull through.
- While holding valve in hand, engage the valve into the ring, rotate ring counterclockwise until hand tightened.
- Prime the hand-held applicator as shown in section 5.1.1.

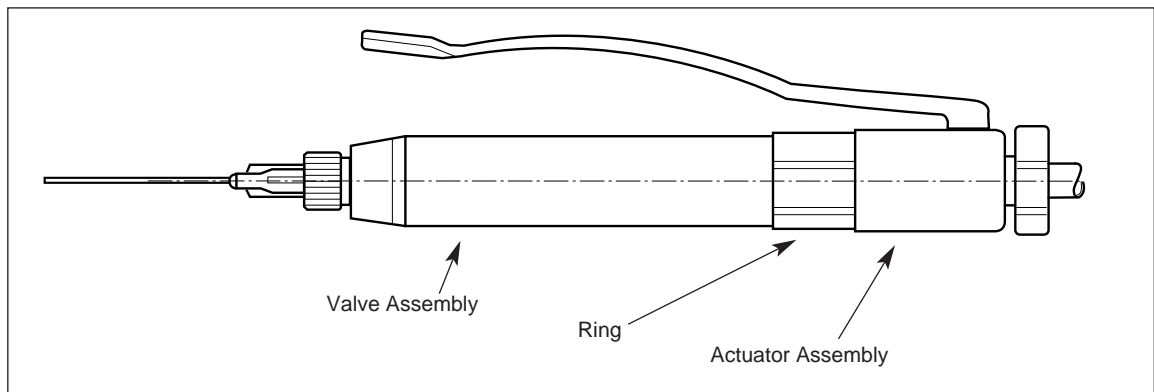

Type of malfunction	Possible causes	Correction
No product or too little product.	<ul style="list-style-type: none"> – Stroke is too small. – Product feedline not correctly connected. – Pressurized air feedline not correctly connected (97112 / 97116). – Curing in the product feedline and/or in the dispensing valve and/or in the dispensing needle. – Air in the product feedline and/or in the dispensing valve and/or in the dispensing needle. – Controller incorrectly adjusted. – Product reservoir not switched on or reservoir pressure too low. 	<ul style="list-style-type: none"> ● Increase stroke by adjusting knob. ● Correctly connect the product feedline. ● Correctly connect the pressurized air line. ● Replace the product feedline and/or dispensing valve and/or dispensing needle. ● Purge the product feedline, dispensing valve and dispensing needle of air (Section 5.1.1). ● Check the controller. Loctite Service. ● Check to make sure product reservoir is pressurized and/or increase reservoir pressure.
Air bubbles in product.	<ul style="list-style-type: none"> – Air in the dispensing valve/product feedline 	<ul style="list-style-type: none"> ● Purge the product feedline, dispensing valve and dispensing needle of air (Section 5.1.1).
Product comes delayed after a start.	<ul style="list-style-type: none"> – Piston stroke (suck-back effect) too large. 	<ul style="list-style-type: none"> ● Reduce the piston stroke. (Section 5.1.2.1).
Product drips.	<ul style="list-style-type: none"> – Piston stroke (suck-back effect) too small. 	<ul style="list-style-type: none"> ● Increase the piston stroke.



- Fold out the illustration inside the front cover.

No.	Description	Loctite Order No.
1	Hand-held Applicator Pistol Grip	97237
2	Dispense Needle, Polyethylene – Conical (PPC),	
	Dispense Needle PPC16GA (50 pcs/box), ID Size 1.20 mm, grey	97221
	Dispense Needle PPC18GA (50 pcs/box), ID Size 0.84 mm, green	97222
	Dispense Needle PPC20GA (50 pcs/box), ID Size 0.58 mm, pink	97223
2	Dispense Needle, Stainless Steel – Standard (SSS),	
2	Dispense Needle, Polypropylene – Flexible (PPF),	
4	Luer-Lok Adapter Kit	97233
5	Hand-held Applicator Actuator – manual	97234
7	Hand-held Applicator Switch – electrical	97236
8	Hand-held Applicator Actuator – pneumatic	97235
9	Replacement Valve Assembly.....	97999
10	Hand-held Applicator Accessory Kit	97220
11	Filter regulator (Not shown).....	97120
12	Pencil holder (Not shown).....	97206

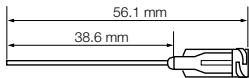
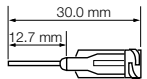
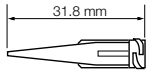

Loctite expressly warrants that all products referred to in this Instruction Manual under Hand-held Applicator 97111/97112 or 97116 (hereafter called "Products") shall be free from defects in materials and workmanship. Loctite's liability shall be limited, at its option, to replacing those Products which are shown to be defective either in materials or workmanship or to credit to the purchaser the amount of the purchase price thereof (plus freight and insurance charges paid therefore by the user). The purchaser's sole and exclusive remedy for breach or warranty shall be such replacement or credit.

A claim of defect in materials or workmanship in any Products shall be allowed only when it is submitted to Loctite in writing within one month after discovery of the defect or after the time the defect should reasonably have been discovered and in any event, within twelve months after the delivery of the Products to the purchaser. No such claim shall be allowed in respect of Products which have been neglected or improperly stored, transported, handled, installed, connected, operated, used or maintained or in the event of unauthorized modification of the Products including, where products, parts or attachments for use in connection with the Products are available from Loctite, the use of products, parts or attachments which are not manufactured by Loctite.

No Products shall be returned to Loctite for any reason without Loctite's prior written approval. Products shall be returned freight prepaid, in accordance with Loctite's instructions.

NO WARRANTY IS EXTENDED TO ANY EQUIPMENT WHICH HAS BEEN ALTERED, MISUSED, NEGLECTED, OR DAMAGED BY ACCIDENT, OR IF THE SYSTEM IS USED TO DISPENSE ANY LIQUID MATERIAL OTHER THAN LOCTITE CORPORATION PRODUCTS.

EXCEPT FOR THE EXPRESS WARRANTY CONTAINED IN THIS SECTION, LOCTITE MAKES NO WARRANTY OF ANY KIND WHATSOEVER, EXPRESS OR IMPLIED, WITH RESPECT TO THE PRODUCTS.

ALL WARRANTIES OF MERCHANTABILITY, FITNESS FOR A PARTICULAR PURPOSE, AND OTHER WARRANTIES OF WHATEVER KIND (INCLUDING AGAINST PATENT OR TRADEMARK INFRINGEMENT) ARE HEREBY DISCLAIMED BY LOCTITE AND WAIVED BY THE PURCHASER.

THIS SECTION SETS FORTH EXCLUSIVELY ALL OF LOCTITE'S LIABILITY TO THE PURCHASER IN CONTRACT, IN TORT OR OTHERWISE IN THE EVENT OF DEFECTIVE PRODUCTS.

WITHOUT LIMITATION OF THE FOREGOING, TO THE FULLEST EXTENT POSSIBLE UNDER APPLICABLE LAWS, LOCTITE EXPRESSLY DISCLAIMS ANY LIABILITY WHATSOEVER FOR ANY DAMAGES INCURRED DIRECTLY OR INDIRECTLY IN CONNECTION WITH THE SALE OR USE OF, OR OTHERWISE IN CONNECTION WITH, THE PRODUCTS, INCLUDING, WITHOUT LIMITATION, LOSS OF PROFITS AND SPECIAL, INDIRECT OR CONSEQUENTIAL DAMAGES, WHETHER CAUSED BY LOCTITE'S NEGLIGENCE OR OTHERWISE.

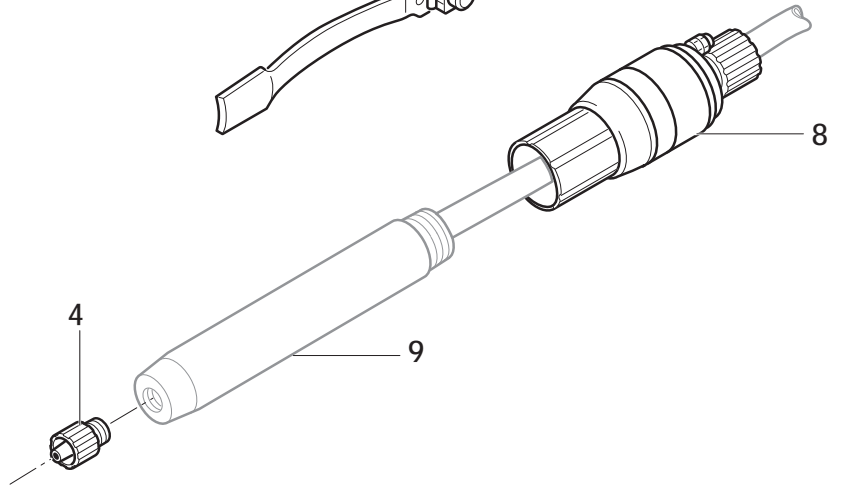
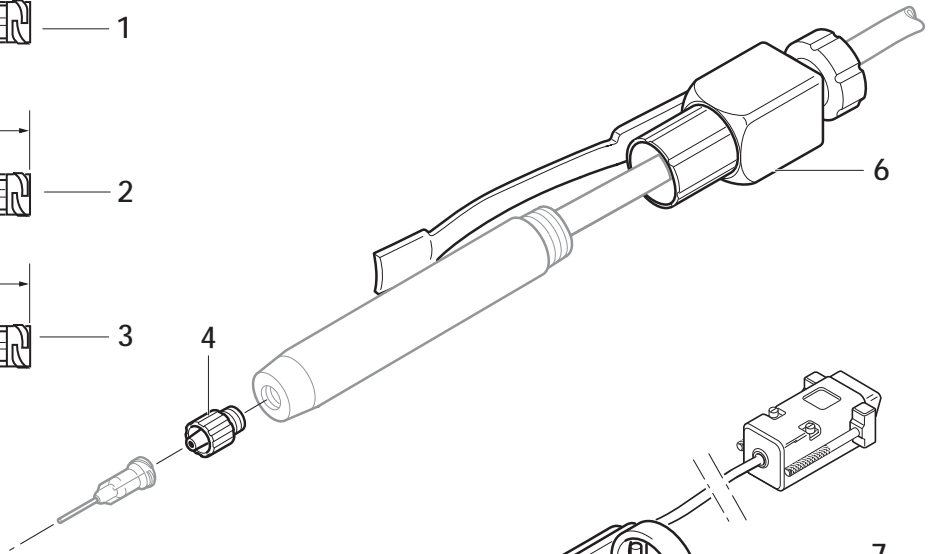
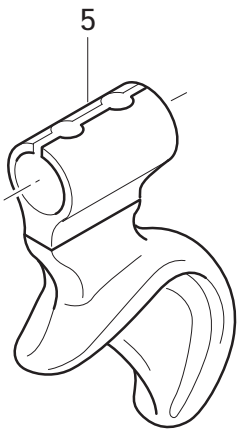
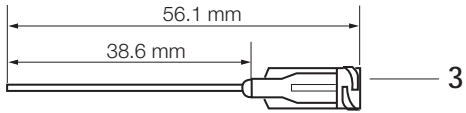
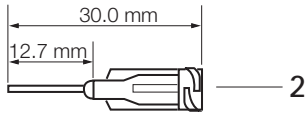
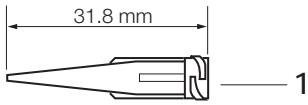

CE – Declarations of Conformity

Manufacturer



**Loctite
Corporation**

Loctite (Ireland) Ltd.
Tallaght Business Park
Whitestown
Tallaght, Dublin 24, Ireland
North American Group
1001 Trout Brook Crossing
Rocky Hill, CT USA 06067

declares that machine contained in this delivery is the machine designated below, is however incomplete and that its operation is prohibited until it can be determined that the machine is in accordance with the provisions of EC machine regulations.

Designation of the unit	Handheld Applicator
Unit number	97111 / 97112 or 97116
Applicable EC Regulations	EG-Machine Regulations 89/392/EWG, version 93/68/EWG
Applicable harmonized standards	DIN EN 292 Part 1 11.1991; DIN EN 292 Part 2 11.1991
Date / Manufacturer's signature	1995 
Information regarding the Signer	President – Worldwide Manufacturing (Peter G. Dowling)

For changes to the unit that were not approved by Loctite, this declaration loses its validity.



**Loctite
Corporation**

Loctite (Ireland) Ltd.

Tallaght Business Park
Whitestown

Tallaght, Dublin 24, Ireland

North American Group

1001 Trout Brook Crossing
Rocky Hill, CT USA 06067