

Part No. 98327: 97113 and 97114 Valve Mounting Bracket Kit for Loctite® Robots

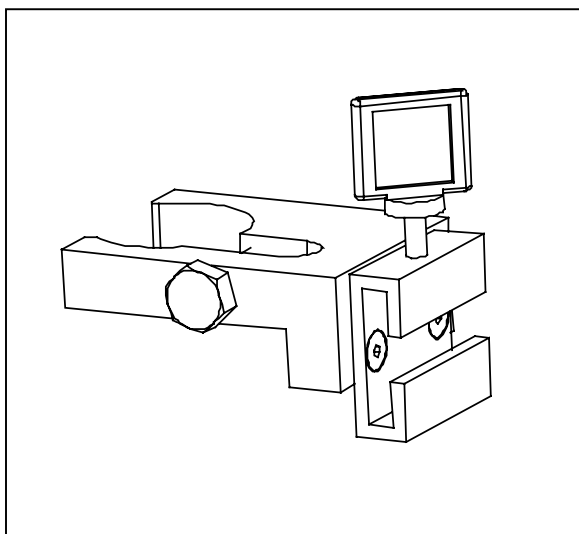

Description:

The 98327 mounting bracket kit is designed for holding 97113 or 97114 valve when using Loctite® 3 or 4 axis robots. The “C” rail connection allows for more than one bracket to be used when using 3 axis robots. This allows for multiple dispense points to increase throughput. **A mounting rail, plate or adapter must be purchased separately to mount the brackets on the robot.**

Includes:

Qty	Description
1	97113 or 97114 valve mounting bracket kit

Instructions for Use:

3 Axis Benchtop Robots

1. Attach the mounting rail to the robot using the two M5 x 12 mm socket head cap screws.
2. Slide the “C” rail on the back of the mounting bracket over the “T” shaped mounting rail.
3. Fix the position of the mounting bracket by manually tightening the white nylon thumbscrew.

3 Axis SCARA Robots

1. Remove the two flat head screws from the “C” rail on mounting bracket kit.
2. Position the mounting bracket clamping block on front side of the mounting plate and line up the mated assembly on the robot to determine where the mounting plate and mounting bracket should be attached.
3. Attach the mounting bracket to the plate with the two 8-32 x ½” socket head cap screws.
4. Attach the mounting plate on the robot using the two M5 x 12 mm socket head cap screws.

4 Axis SCARA Robots

1. Remove the two flat head screws from the “C” rail on mounting bracket kit.
2. Disassemble the 360 adapter at the bottom of the 4 axis mounting adapter by loosening the two set screws.
3. Place the male component of the 360 adapter over the mounting bracket clamping block.
4. Attach the male component of the 360 adapter to the mounting bracket clamping block using the two 8-32 flat head screws removed from the “C” rail.
5. Re-assemble the 360 degree adapter.

Parts and Accessories:

Please see the other side for required parts that must be ordered separately and optional accessories.



Henkel Corporation
1001 Trout Brook Crossing
Rocky Hill, CT 06067
USA

Phone 860.571.5174
Fax 860.571.5131
Equipment-customerservice@loctite.com

Required: * Must Be Purchased Separately *****

3 Axis Benchtop Robots. One of the three mounting rails listed below is required. The mounting rail is mounted directly to the robot on Benchtop robots. The "C" rail on the mounting bracket then slides over the mounting rail, which has a "T" shape. The small rail is used for a single dispense point. The larger rails are used for multiple dispense points.

Part No.	Description
98328	3 3/4 inch bar with two cap screws
98329	8 3/4 inch bar with two cap screws
98330	12 inch bar with two cap screws

3 Axis SCARA Robots. The mounting plate listed below is required. The mounting plate is mounted directly to the robot and allows for up to approximately 5" of rough adjustment of the mounting bracket z-height from the mounting holes on the robot.

Part No.	Description
98337	Mounting plate for SCARA robot

If z-height adjustment is not needed, a complete valve holder is also available (Loctite® Part No. 98343). This has everything required to mount one 97113 or 97114 valve and does not require that the mounting bracket kit be ordered separately.

4 Axis Robots. The mounting adapter listed below is required. The mounting adapter connects to the z-axis on the robot on one end and the mounting bracket on the other end.

Part No.	Description
98336	Mounting adapter for 4 axis robots

Optional Accessories:

Integrated Dispense Controllers. These are reservoirs integrated with digital dispense controllers. When connected to the dispense valve, they offer a complete dispensing solution.

Part No.	Description
97007	Integrated Semiautomatic Controller and Reservoir, 0-100 psi
97010	Integrated Semiautomatic Controller and Reservoir, 0-15 psi
97017	Integrated Semiautomatic Controller and Reservoir, 0-100 psi, with low level sensor
97020	Integrated Semiautomatic Controller and Reservoir, 0-15 psi, with low level sensor

Solenoid Valve Module. This is used to control the valve directly using the I/O from the robot. If this unit is purchased, any pressure reservoir can be used to supply adhesive to the valve.

Part No.	Description
988000	Solenoid valve module.

Tip Locator Bracket. The tip locator bracket is used to mechanically set the tip height during installation so that the program does not need to be corrected after a tip change. These are sized for 1" long, 25 gauge needles and must be modified by the user for larger gauge sizes.

Part No.	Description
98335	Tip locator bracket for 97113 or 97114 valves

Z-Height Adjustment Plate. When using a mounting rail attached directly to the robot, it may not be possible to bring the dispense tip in contact with a flat part on the 400 Series robot. When using the 200 series robot, a large part may require that the dispense tip be mounted further away. This plate allows for up to 6" of rough adjustment of the location of the mounting bracket above or below the mounting hole in the robot.

Part No.	Description
98357	Z height adjustment plate