

EQ RC32 Automatic Reservoir SP**IDH 2814023****PRODUCT DESCRIPTION**

The Loctite EQ RC32 Automatic Reservoir is equipped with a single point low level sensor that sends an electronic signal to a Loctite brand controller and is typically integrated into a dispensing system that consist of a dispensing valve and one of these controllers. The reservoir can be applied directly from the original 250ml, 500gram, 1 liter ,2 kg and 200gram adhesive packages.

**Product Features**

- Modular design allows user to build suited application process.
- Operational with manual, semi-automatic and automatic controllers.
- Low level sensor alarm provides warning for adhesive bottle replacement.
- Integrated solenoid vent valve

Technical Data:

- Dimensions:
 - Width: 214mm
 - Depth: 366mm
 - Height: 363mm
- Weight: 4 kg.
- Operation temperature: + 10 Deg. C to +40 Deg. C. (+50 Deg. F. to +104 Deg. F.)

Automatic Reservoir Includes:

- Operation Manual
- Reservoir Tank Fitting: ¼ inch NPT x ¼ Inch Tubing
- Tank Cord
- Bottle Holder
- Anti-bubbler Fitting and Tube Kit
- Tube of silicone grease

Optional Accessories and System Components (sold separately):

- Stationary Dispense Valve. (1/4" feedline), item # 97113 (IDH88644)
- Stationary Dispense Valve. (3/8" feedline), item # 97114 (IDH88645)
- Light Cure Dispense Valve, item # 98009 (IDH218280)
- Cyanoacrylate Dispense Valve, item # 98013 (IDH318654)
- Hand-held LV Applicator, item # 97130 (IDH444643)



EQ RC32 Automatic Reservoir SP**IDH 2814023****Recommended Spare Parts / Accessories:**

- Air Filter / Regulator, US region - item # 985397 (IDH478603)
- Air Filter / Regulator, EU/Asia region - item # 97120 (IDH88649)
- Reservoir Tank Fitting: ¼ inch NPT x ¼ Inch Tubing, item # 8900064 (IDH360636)
- Footswitch, item # 97201 (IDH88653)
- Feedline tubing, ¼ inch O.D. black PE lined, 10mtr/33ft length, item # 97972 (IDH142646)
- Tank Lid O-ring for reservoir, item # 981880 (IDH478505)
- Pressure safety relief valve, item # 992641 (IDH360462)
- Anti-bubbler Kit, (2 adapters & 2 sleeves), item # 984687 (IDH478669)
- Silicone grease, 6gram tube, item # 997569 (IDH88722)

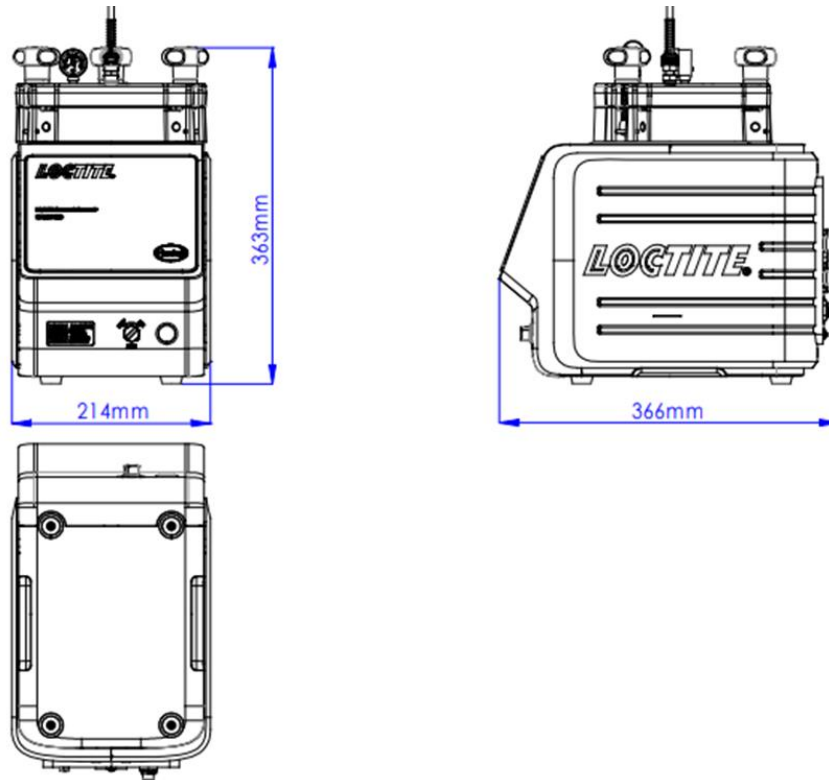
Dimensions:**Note**

The data contained herein are furnished for information only and are believed to be reliable. We cannot assume responsibility for the results obtained by others over whose methods we have no control. It is the user's responsibility to determine suitability for the user's purpose of any production methods mentioned herein and to adopt such precautions as may be advisable for the protection of property and of persons against any hazards that may be involved in the handling and use thereof. In light of the foregoing, Henkel Corporation specifically disclaims all warranties expressed or implied, including warranties of merchantability or fitness for a particular purpose, arising from sale or use of Henkel Corporation's products. Henkel Corporation specifically disclaims any liability for consequential or incidental damages of any kind, including lost profits. The discussion herein of various processes or compositions is not to be interpreted as representation that they are free from domination of patents owned by others or as a license under any Henkel Corporation patents that may cover such processes or compositions. We recommend that each prospective user test his proposed application before repetitive use, using this data as a guide. This product may be covered by one or more United States or foreign patents or patent applications.

Trademark usage except as otherwise noted, all trademarks in this document are trademarks of Henkel Corporation in the U.S. and elsewhere. ® denotes a trademark registered in the U.S. Patent and Trademark Office.