



# EQ RC32 Automatic Reservoir SP

IDH 2814023

Operating Manual



# Table of Contents

|     |   |    |
|-----|---|----|
| 1   | Please Observe the Following .....                | 3  |
| 1.1 | Emphasized Sections.....                          | 3  |
| 1.2 | For Your Safety.....                              | 3  |
| 1.3 | Unpacking and Inspection .....                    | 3  |
| 1.4 | Packing List.....                                 | 4  |
| 1.5 | Features.....                                     | 4  |
| 1.6 | Field of Application (Intended use) .....         | 4  |
| 2   | Description.....                                  | 5  |
| 2.1 | Theory of Operation.....                          | 5  |
| 2.2 | Control Panel (Front & Back of controller).....   | 6  |
| 3   | Technical Data.....                               | 7  |
| 4   | Installation.....                                 | 8  |
| 4.1 | Environmental and Operating Conditions.....       | 8  |
| 4.2 | Connecting the Unit.....                          | 8  |
| 4.3 | Filling and Refilling the Product Reservoir ..... | 9  |
| 5   | Operation.....                                    | 10 |
| 5.1 | First Operation.....                              | 10 |
| 5.2 | Adjust the Lebel Sensor.....                      | 11 |
| 6   | Application Hints.....                            | 12 |
| 7   | Troubleshooting.....                              | 13 |
| 8   | Care and Maintenance .....                        | 14 |
| 9   | Accessories and Spare Parts.....                  | 15 |
| 10  | Diagrams .....                                    | 15 |
| 11  | Warranty .....                                    | 16 |
| 12  | Declaration of Conformity.....                    | 17 |

---

# 1 Please Observe the Following

---

## 1.1 Emphasized Sections

### **Warning!**

Refers to safety regulations and requires safety measures that protect the operator or other persons from injury or danger to life.

### **Caution!**

Emphasizes what must be done or avoided so that the unit or other property is not damaged.

### **Notice:**

A notice gives recommendations for better handling of the unit during operation or adjustment as well as for service activities.

## 1.2 For Your Safety

 For safe and successful operation of the unit, read these instructions completely. If the instructions are not observed, the manufacturer can assume no responsibility.

 Do not expose the connecting cable to heat, oil, or sharp edges.

 Make sure the Unit stands stable and secure.

 Use only original equipment replacement parts.

 Always disconnect the power supply before servicing the unit.

 Observe general safety regulations for the handling of chemicals such as Loctite® adhesives and sealants. Observe the manufacturer's instructions as stated in the Safety Data Sheet.

 While under warranty, the unit may be repaired only by an authorized Loctite service representative.

## 1.3 Unpacking and Inspection

Carefully unpack the Loctite® EQ RC32 Automatic Reservoir SP and examine the items contained in the carton. Inspect the unit for any damage that might have occurred in

transit. If such damage has occurred, notify the carrier immediately. Claims for damage must be made by the consignee to the carrier and should be reported to the manufacturer.

#### **1.4 Packing List**

- EQ RC32 Automatic Reservoir SP x 1
- Equipment Manual x 1
- Reservoir Tank Fitting: ¼ inch NPT x ¼ Inch Tubing x 1
- Bottle Holder x 1
- ¼” NPT to 6 mm inlet supply line connector x 1
- Anti-Bubbler Fitting and Tubing Kit x 1
- Tank Cord x 1
- Bottle spacer disc x 1

#### **1.5 Features**

- Modular design allows user to build suited application process.
- Operational with semi-automatic and automatic controllers.
- Single point product level sensor for process controls.
- Integrated solenoid vent valve.

#### **1.6 Field of Application (Intended use)**

The Loctite EQ RC32 Automatic Reservoir SP is equipped with a single point low level sensor that sends an empty signal to a Loctite brand controller and is typically integrated into a dispensing system that consist of a dispensing valve and one of these controllers. The adhesive can be applied directly from the original 250ml, 500gram, 1 liter, and 2 kg adhesive packages.

With the EQ RC32 Automatic Reservoir SP, anaerobic, UV Curing and cyanoacrylate adhesive can be dispensed.

The capacity of the EQ RC32 Integrated Reservoir is:

- |  |                 |
|--|-----------------|
| -500 gr. bottle for CA Products                      | -1 lb. bottle   |
| -250 ml bottle for Anaerobic                         | -1 Liter bottle |
| -Bottle with a $\phi$ 124mm and<br>a height of 250mm | -2kg bottle     |

---

## 2 Description

---

### 2.1 Theory of Operation

The original LOCTITE® bottle is inserted into the EQ RC32 Automatic Reservoir SP. The closed reservoir is supplied with regulated, pressurized air from the LOCTITE® controller 97102, 97152 or RC15. As long as the dispensing valve is open, pneumatic pressure on the surface of the fluid in the original LOCTITE® bottle transports the product through the product line.

#### **Notice:**

When connected to a controller 97102, 97152 or RC15, the automatic reservoir is automatically pressurized when the controller is switched on and automatically depressurized when the controller is switched off.

The EQ RC32 Automatic Reservoir SP includes a single point low level sensor that detects when the level of fluid inside the bottle within the reservoir is low and requires re-filling. This sensor should be connected directly to a Loctite controller (97102, 97152 or RC15) which provides the warning information and signals. Alternatively, the Low level sensor can be connected to an external PLC or controller.

## 2.2 Operating Elements and Connections

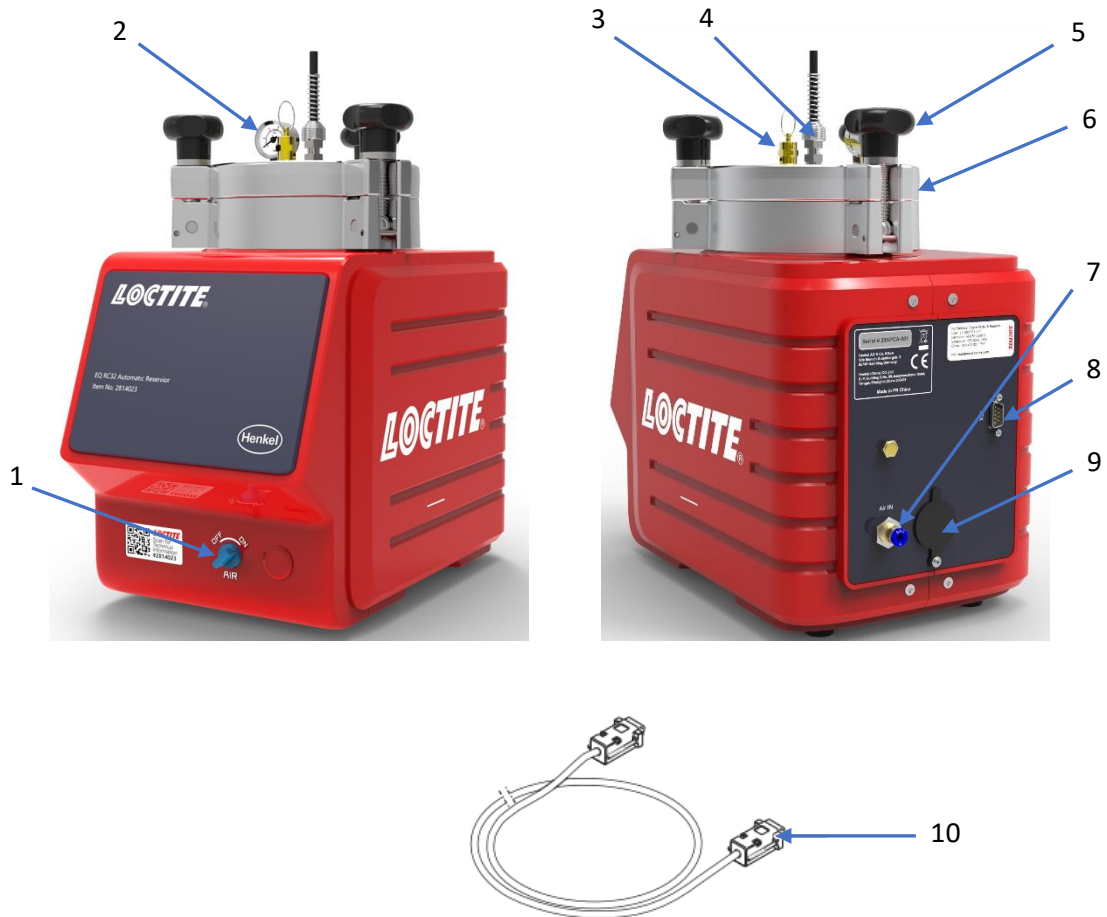

1. Air Pressure ON/OFF Switch
2. Tank Pressure Gauge
3. Valve Pressure Relief
4. Reservoir/Feedline Fitting
5. Reservoir Locking Knob x 3

6. Reservoir Lid
7. Pneumatic Connection P in
8. Low Level connector XS2
9. Low Level Sensor
10. Tank cord

---

### 3 Technical Data

---

|                            |  |
|----------------------------|--|
| Dimensions (W x H x D):    | 214x363x366 mm   |
| Total weight: Kg (lbs.)    | 4 (8.8)  |
| Internal control voltages: | 24VDC  |
| Pneumatic Supply:          | Clean, dry air not to exceed 116 psi (8bar). and filtered with a maximum of 10 micron. |
| Pneumatic hose size:       | External dia. 6mm  |
| Operating Temperature:     | +10 ° C to +40 ° C (+50 ° F to +104 ° F)   |
| Storage Temperature:       | - 10 ° C to +60 ° C (+14 ° F to +140 ° F)  |

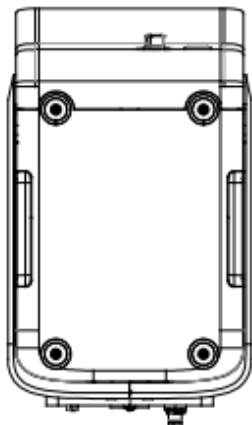
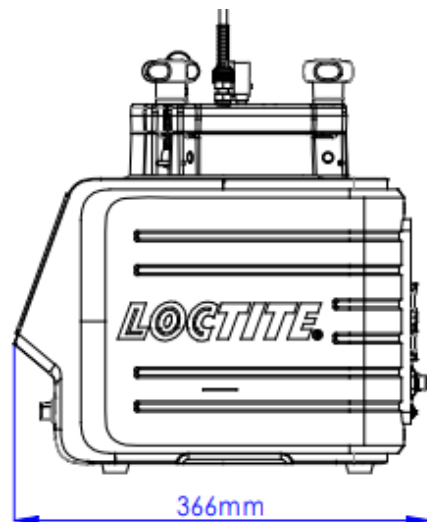
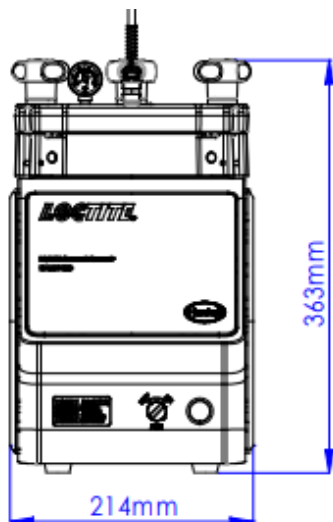

---

## 4 Installation

---

**!** Before using the equipment for the first time check it carefully for signs of external damage. If any shipping damage is found DO NOT USE THE EQUIPMENT – return it to your supplier immediately.

### 4.1 Environmental and Operating Conditions

- Keep product feedline as short as possible. The shorter the feedline the smaller the specific resistance and lower the dispensing pressure can be. Avoid kinking of the feedline.
- Use flexible pneumatic hoses and Loctite supplied product feedlines to prevent unnecessary loads on the fitting and to ensure compatibility.
- Keep all fitting tight.
- No direct sunlight; no UV light.
- No condensing humidity.
- Avoid direct contact with water.

### 4.2 Connecting the Unit

- Use only the cable and hose sets supplied.
- Connect the regulated air pressure supply from the reservoir P in (7) to pneumatic connection P out on the controller.
- Connect the tank cord to the 9 pin D-sub connector XS2 (8) located on the rear panel of reservoir as well as to socket on the controller.

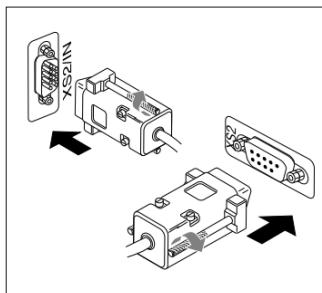

- Insert feedline through the reservoir lid to the dimension shown below. Alternatively use the reference line shown on the housing to set the feedline length. Cut the end of the feedline at an angle as shown below.



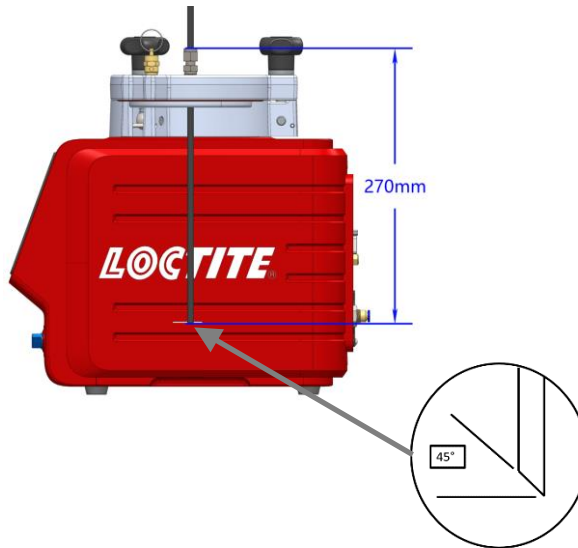

- Connect dispensing valve.



### 4.3 Filling and Refilling the Product Reservoir

#### **⚠ Warning!**

Never fill the product directly into the reservoir!



The pneumatic and safety devices would become clogged and therefore ineffective!

#### **⚠ Warning!**

**Before loosening the reservoir locking knobs (6), the EQ RC32 Automatic Reservoir must be depressurized (pressure-free)!**

When dispensing cyanoacrylate and an empty signal is shown, refill the product reservoir immediately, since air in the product line results in curing of the product!

The reservoir is depressurized when the depressurizing valve (1) is in “OFF” position and pressure gauge (2) indicates no pressure.

- Loosen the reservoir locking knobs (5) and remove lid (6).
- Check that there is no condensed moisture at the bottle or the sensor surface.
- Place the bottle in the bottle holder (see the right figure).
- Check that the product bottle inserted in the bottle holder is pressed against the level sensor.
- Insert the product feedline into the bottle and put on the lid.
- Uniformly tighten the reservoir knobs by hand.
- Set the depressurizing valve (1) to “ON” position (pressurize).
- On the controller 97102, switch the reservoir to active with the button 
- On the controller 97152 or RC15 switch the reservoir to active with button 



---

## 5 Operation

---

### 5.1 First Operation

The automatic reservoir is depressurized when the power switch on the controller 97102, 97152 or RC15 is switched to the O (OFF) position or the tank pressure gauge indicates no pressure.

In any case:

- Set the depressurizing valve (1) to position  (depressurize).
- Check that the dispensing valve is connected correctly according to the instruction manual.

### Inserting the Product Bottle

Follow procedure as described in section 4.3.

## 5.2 Adjust the Level Sensor

### Notice:

The level sensor is set in manufacturing and can be adjusted according to the type of product used, the size of the bottle, and orientation of the basket with spacers if required. If small bottles are used the supplied Bottle spacer disc can be placed in the base of the reservoir to raise the height of the bottle to reduce the residual adhesive in the bottle when low level is used.

Before adjusting the Level Sensor

1. Remove the plastic cap from the backside of reservoir.
2. Connect the reservoir cord to the connector XS2 (8) on the reservoir as well as to socket XS2 on the controller.
3. Empty a bottle of the product you use.
4. Leave as much residue in the bottle as is required in order to prevent air getting into the product feed line.
5. Insert the product bottle. For small bottles use the bottle holder. For 250ml product bottle, pay attention to ensure the bottle is aligned with the level sensor.
6. Check that the product bottle inserted into the bottle holder is pressed against the level sensor. Only then the correct adjustment of the level sensor is possible.



Procedure to Adjust the Level Sensor:

1. Switch on the power switch of the controller 97102, 97152 or RC15 to supply the reservoir with voltage 24 VDC.
2. Turn controller power switch - "ON".
3. Remove the metal screw from the level sensor.
4. With an electrician's screwdriver, find the point at which the sensor switches to the condition inactive. The LED is OFF".
5. Check this adjustment with a full bottle and an empty bottle again.
6. Refit the metal screw to the level sensor.
7. Put the plastic cap back.

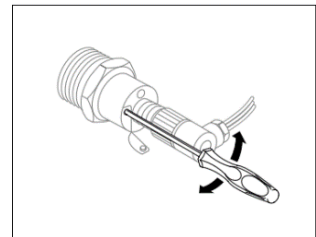

### Notice:

The correct adjustment is exactly the point when the sensor switches "OFF".

**Do not go beyond that point!**

---

## 6 Application Hints

---

As with all adhesives, performance depends on conditions of use. Suggestions or recommendations contained herein are for guidance only since actual conditions of use are outside the supplier's control.

### 6.1 Shutdown for Longer Periods of Non-use (>recommended idle time)

- Disconnect the pneumatic supply from the unit.
- Clean the product hose and dispensing valve.

Recommended maximum idle times for different products are shown below:





| <b>Adhesive</b> | <b>Maximum idle time for dispensing Systems</b> |
|-----------------|---|
| Anaerobic       | 2 weeks   |
| Cyanoacrylate   | 1 week  |
| UV-acrylate     | 2 weeks   |
| Acrylate        | 1 week  |
| Epoxy           | 2 weeks   |
| Activator       | n.a.  |
| Primer          | n.a.  |

### 6.2 Returning to Operation after Longer Periods of Non-use

- Reconnect the pneumatic supply to the unit.
- Check the installation according to Chapter 4.
- Return to operation according to Section 5.1.

## 7 Troubleshooting

⚠ Before proceeding with any repair or maintenance operation disconnect the EQ RC32 Automatic Reservoir SP from the main air supply.

| Malfunction  | Possible Cause   | Corrective   |
|--|--|--|
| Pressurized air escapes between reservoir housing and reservoir lid. | Reservoir Knob is not tightened.                       | Tighten the reservoir knob.  |
|  | O-ring leaks.  | Grease or renew the O-ring.  |
| Pressurized air escapes at the product connection 4.                 | Union nut on the product connection 4 not tightened.   | Carefully tighten the union nut.   |
| Air bubble in the product  | Product reservoir is empty.                            | Refill product reservoir (see section 4.3).  |
|  | Dispensing valve not correctly connected or defective. | Check the dispensing valve (see instruction manual for dispensing valve).  |
|  | Product reservoir pressure is too high.                | Lower pressure, longer dispensing time.  |
| Too little product.  | Dispensing pressure inadequate.                        | Increase the dispensing pressure on the controller.  |
|  | Air supply pressure inadequate.                        | Increase the air supply pressure.  |
|  | Malfunction of the dispensing valve.                   | Check the dispensing valve, see operating instructions of the dispensing valve.  |
| No product.  | Product reservoir is empty.                            | Refill the product reservoir (Section 4.3)   |
|  | Product reservoir is not switched on.                  | Set the depressurizing valve to  pressurize.  |
|  | Reservoir (product reservoir) is not active.           | Controller 97102: Press <br>Controller 97152: Press <br>Controller RC15: Press  |
|  | Product reservoir defect.                              | Henkel Service.  |

---

## 8 Care and Maintenance

---

### 8.1 Care

-Occasionally the O-ring at the reservoir lid should be lubricated with silicone grease. This will prolong the life of the O-ring.

 **Notice:** Clean hands after application of grease to ensure surfaces to be bonded are clean.

-Clean the sensor surface as required.

-Both the bottle surface and the sensor surface must be free of condensed moisture!

### 8.2 Cleaning

-Prior to extended idle times or when changing of the product type, clean the product hose and the dispensing valve.

-Loosen reservoir locking knobs (5) and remove the reservoir lid (6).

-Clean product residue from the outside of the feedline hose.

-Remove the product bottle and insert a container with approx. 0.5 liter of cleaning agent.

-Put on the reservoir lid (6) and uniformly tighten the reservoir locking knobs (5).

-Operate the dispenser continuously until dry air streams out of the dispensing valve (see operating instructions for the dispensing valve).

-Remove the empty cleaning agent container.

### 8.3 Maintenance

-Check the reservoir knobs and the product feed line on the regular basis. If there is any sign of cracks, replace them!

-Clean, dry, filtered air must be used. If it is not, the solenoids on the controller will be fouled over time.

 **Notice:** If the required air quality is not achieved, install a Loctite® filter regulator. In the US order a 5 µm filter using Part Number 478603. In Europe or Asia, order a 10 µm filter using Part Number 88649.

## 9 Accessories and Spare Parts

| Item               | Description  | IDH#   |
|--------------------|--|--------|
| <b>Spare Parts</b> |  |        |
| 1                  | Reservoir/tube Tank Fitting, ¼ inch NPT x ¼ inch Tubing            | 360636 |
| 2                  | Tank Cord, 2 m   | 147521 |
| 3                  | ¼ inch O.D. Black PE Teflon Lined feedline Tubing (33 feet length) | 142646 |
| 4                  | Reservoir Lid O-ring   | 478505 |
| 5                  | Pressure Safety Relief Valve                                       | 360462 |
| 6                  | Anti-Bubbler Kit, 2 Adapters & 2 Sleeves                           | 478569 |
| 7                  | Silicone Grease, 6 Gram Tube                                       | 88722  |

## 10 Diagrams

EQ RC32 Automatic Reservoir SP Pin Connection:

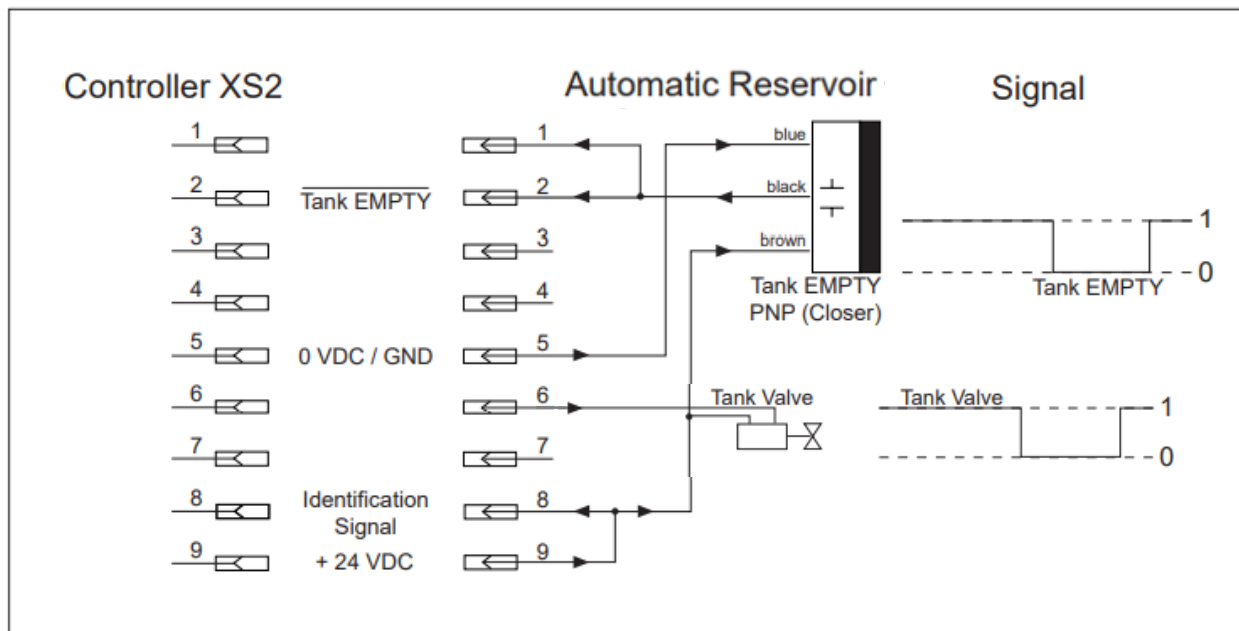

---

## 11 Warranty

---

Henkel expressly warrants that all products referred to in this Instruction Manual for Loctite® EQ RC32 Automatic Reservoir SP (hereafter called “Products”) shall be free from defects in materials and workmanship. Liability for Henkel shall be limited, as its option, to replacing those Products which are shown to be defective in either materials or workmanship or to credit the purchaser the amount of the purchase price thereof (plus freight and insurance charges paid therefor by the user). The purchaser’s sole and exclusive remedy for breach of warranty shall be such replacement or credit.

A claim of defect in materials or workmanship in any Products shall be allowed only when it is submitted in writing within one month after discovery of the defect or after the time the defect should reasonably have been discovered and in any event, within (12) months after the delivery of the Products to the purchaser. This warranty does not apply to perishable items, such as fuses, filters, lights, etc.. No such claim shall be allowed in respect of products which have been neglected or improperly stored, transported, handled, installed, connected, operated, used or maintained. In the event of unauthorized modification of the Products including, where products, parts or attachments for use in connection with the Products are available from Henkel, the use of products, parts or attachments which are not manufactured by Henkel, no claim shall be allowed.

No Products shall be returned to Henkel for any reason without prior written approval from Henkel. Products shall be returned freight prepaid, in accordance with instructions from Henkel.

NO WARRANTY IS EXTENDED TO ANY EQUIPMENT WHICH HAS BEEN ALTERED, MISUSED, NEGLECTED, OR DAMAGED BY ACCIDENT.

EXCEPT FOR THE EXPRESS WARRANTY CONTAINED IN THIS SECTION, HENKEL MAKES NO WARRANTY OF ANY KIND WHATSOEVER, EXPRESS OR IMPLIED, WITH RESPECT TO THE PRODUCTS.

ALL WARRANTIES OF MERCHANTABILITY, FITNESS FOR A PARTICULAR PURPOSE, AND OTHER WARRANTIES OF WHATEVER KIND (INCLUDING AGAINST PATENT OR TRADEMARK INFRINGEMENT) ARE HEREBY DISCLAIMED BY HENKEL AND WAIVED BY THE PURCHASER.



THIS SECTION SETS FORTH EXCLUSIVELY ALL OF LIABILITY FOR HENKEL TO THE PURCHASER IN CONTRACT, IN TORT OR OTHERWISE IN THE EVENT OF DEFECTIVE PRODUCTS.

WITHOUT LIMITATION OF THE FOREGOING, TO THE FULLEST EXTENT POSSIBLE UNDER APPLICABLE LAWS, HENKEL EXPRESSLY DISCLAIMS ANY LIABILITY WHATSOEVER FOR ANY DAMAGES INCURRED DIRECTLY OR INDIRECTLY IN CONNECTION WITH THE SALE OR USE OF, OR OTHERWISE IN CONNECTION WITH, THE PRODUCTS, INCLUDING, WITHOUT LIMITATION, LOSS OF PROFITS AND SPECIAL, INDIRECT OR CONSEQUENTIAL DAMAGES, WHETHER CAUSED BY NEGLIGENCE FROM HENKEL OR OTHERWISE.

---

## **12 Declaration of Conformity**

---

TO BE CONFIRMED - SG

**Henkel Corporation**

One Henkel Way  
Rocky Hill, CT 06067-3910  
USA

**Henkel Capital, S.A. de C.V.**

Calzada de la Viga s/n Fracc.  
Los Laureles  
Loc. Tulpetlac, C.P. 55090  
Ecatepac de Morelos, MEXICO

**Henkel Loctite Korea**

8F, Mapo Tower, 418,  
Mapo-dong, Mapo-gu,  
Seoul, 121-734, KOREA

**Henkel Canada Corporation**

2515 Meadowpine Boulevard  
Mississauga, Ontario L5N 6C3  
Canada

**Henkel Singapore Pte Ltd**

401, Commonwealth Drive  
#03-01/02 Haw Par Technocentre  
SINGAPORE 149598

**Henkel Japan Ltd.**

27-7 Shin Isogo-cho, Isogo-ku  
Yokohama, 235-0017  
JAPAN

**Henkel Corporation****Automotive/ Metals H.Q.**

32100 Stephenson Hwy,  
Madison Heights 48071  
USA

**Henkel (China) Company Ltd.**

No. 928 Zhang Heng Road,  
Zhangjiang, Hi-Tech Park, Pudong,  
Shanghai, China 201203

**Henkel AG & Co. KGaA**

Henkelstraße 67,  
40191 Düsseldorf  
Deutschland

**[www.equipment.loctite.com](http://www.equipment.loctite.com)**

® and ™ designate trademarks of Henkel Corporation or its affiliates. ® = registered in the U.S. and elsewhere.

© Henkel Corporation. All rights reserved. Data in this operation manual is subject to change without notice.

Manual P/N: n/a, Rev A, Date: 10/18/2021