



LOCTITE[®]

EQUIPMENT

OPERATION MANUAL



Loctite[®]

98630 Dispense Valve Manual

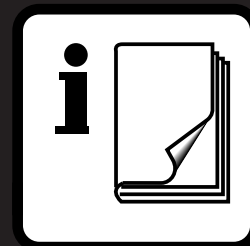

Contents

Section	Description	Page No.
1	Introduction, Cut-away View, Items Supplied	2, 3
2	Theory of Operation	4
3	Instructions: Safety Precautions, Installation, Operation, Shutdown Procedure	5
4	Troubleshooting & Phone Numbers for Help	6
5	Specifications: Dimensional Information, Product Pressure Limit, Control Pressure Information	7
6	Warranty	8

This Dispense Valve is designed to dispense Loctite® high viscosity anaerobic form-in-place gasketing products. It may be used with the Loctite® Pump-A-Bead™ II, Press Pak™ or other dispense systems which provide a source of pressurized product and a 4-way pneumatic valve.

NOTE: This valve not suitable for dispensing moisture cure or highly abrasive products due to the valve materials of construction.

The valve is a poppet type valve with a single lip type seal on the poppet stem.

The poppet design gives the valve a “suck-back” feature to reduce product stringing.

A double acting air cylinder operates the poppet.

Valve parts that contact the Loctite® product are made from high strength plastic material treated with a proprietary Loctite process to be as inert as possible to Loctite® anaerobic products.

The valve uses dispensing nozzles with a bayonet type mounting. Using this type mounting gives improved nozzle end location repeatability because it does not use pipe threads for sealing.

Nozzles are available with outlet diameters of 0.025, 0.035, 0.062 inches.

In addition, an adapter is included to allow use of Luer-Lok needles with the valve. Various size Luer-Lok needles are also included.

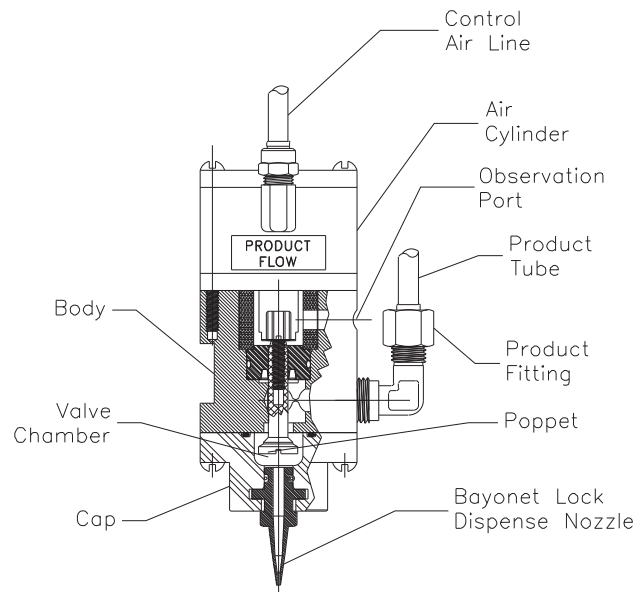

Loctite® 986300 Dispense Valve: Cut-away View

Items Supplied:

986300 Dispense Valve Assembly
includes;

- (1) dispense valve with:
 - (2) 4 ft. long control air tubing (993234).
 - (1) 4 ft. long product supply tubing (999488).
- (1) instruction manual (986302).
- (1) accessory kit (9448768) described below.

Items in 9448768 Accessory Kit**Accessory Kit Item
Repurchase Information**

Item	Description	Repurchase as Loctite Part No.	Repurchase Qty.
1	Fitting, Luer-Lok Adapter	982903	Each
2	Nozzle Assembly, Bayonet, .025 in. id.	986025	Each
3	Nozzle Assembly, Bayonet, .035 in. id.	986035	Each
4	Nozzle Assembly, Bayonet, .062 in. id.	986060	Each
5	Needle, Luer-Lok, 15 gauge (0.052 id x 0.072 od x 0.5 long) 304 sst cannula.	97225	Box of 50
6	Needle, Luer-Lok, 20 gauge (0.023 id x 0.036 od x 0.5 long) 304 sst cannula.	97227	Box of 50
7	Needle, Luer-Lok, 15 gauge (0.049 id x 0.062 od x 1.5 long) polypropylene cannula.	97229	Box of 50
8	Needle, Luer-Lok, 15 gauge (0.060 id x 0.093 od x 0.87 long) one piece polypropylene cannula & hub.	97261	Box of 50
9	Grease, silicone, 6 gr tube	997569	Each

Product is supplied at pressure to valve fluid inlet port.

Compressed air is supplied to air cylinder while “Product Shut Off” port holds poppet on its seat preventing product flow.

Compressed air is exhausted from “Product Shut Off” port and switched to “Product Flow” port.

Poppet moves off its seat and product flows through valve and out of nozzle.

At the end of the desired dispense cycle, the compressed air is exhausted from “Product Flow” port and is switched to “Product Shut Off” port.

This moves the poppet back onto its seat.

As the poppet moves back onto its seat, a straight section of the poppet enters a close-fitting bore in the valve body.

This action creates a seal.

As the poppet travels back further it increases the volume in the valve chamber above the nozzle. This increase in volume produces a slight negative pressure in the chamber above the nozzle. This negative pressure lets atmospheric air pressure push the product column back up the nozzle. This is the “Suck - Back” effect.

The final seal is made when the 120 deg. poppet taper contacts the seat in the valve body.

Relationship of Product Pressure to Control Air pressure:

There is a pressure balance between the Product Pressure and the Control Air Pressure.

This balance is determined by the ratio of the projected poppet area to the air cylinder area.

The ratio is 1 psig of control air pressure to balance 13 psig of product pressure .

For the valve to operate reliably the force available from the air cylinder must be greater than the force available from the product pressure.

Loctite recommends that the product pressure be less than 10 times the control air pressure.

Safety Precautions: Read and observe before working on valve!

Wear protective gear (safety glasses, gloves, aprons, etc.) as required.

Make sure that the control air pressure is zero and that air is “off” and no compressed air is trapped in the air lines.

Make sure that the product pressure is zero and that product is “off” and that no product under pressure is trapped in the product supply lines.

Product under high pressure can penetrate skin and other organs. Always position the dispense nozzle so that it will not discharge in a dangerous manner. Likewise, position any disconnected hoses so that they will not discharge in a dangerous manner.

Installation:

This valve requires a source of pressurized product and a 4-way pneumatic valve to operate.

1. Turn all utilities “OFF” and set the product pressure to zero psig.
2. Connect the normally passing port of the 4-way pneumatic valve to the Dispense Valve “Product Shutoff” port.
3. Connect the normally not passing port of the 4-way pneumatic valve to the Dispense Valve “Product Flow” port.
4. “Connect” the pressurized product source to the Dispense Valve product inlet port (unmarked).

Operation:

1. Turn on utilities. Compressed air to “Product Shutoff” moves poppet onto seat, closing valve.
2. Pressurize product.
3. On initial startup or after replacing empty product container with a full one, remove air from product supply tube and valve as follows:
4. Place container under dispense nozzle.
5. Open dispense valve under manual control to remove air from product supply tube and valve. When air is purged from system, close dispense valve.
6. Resume normal operation.

Shutdown Procedure:

This is the specific procedure to follow if the Dispense Valve is to be shut down overnight or longer when dispensing anaerobic products. This procedure leaves the valve in the open position so that the minimum number of wetted parts are in close contact.

1. Remove all product pressure to the Dispense Valve. It is also advisable to relieve the pressure on the product by setting it to zero.
2. Place a container under the dispense nozzle.
3. Cycle the Dispense Valve to the “Open” or “Product Flow” position. This moves the cylindrical “Suck-Back” section of the poppet out of the valve body. This leaves the minimum number of wetted parts in close contact.
4. When restarting the system, cycle the Dispense valve to the “Closed” or “Product Shut Off” position.

Because of the complex steps in, the chemicals required for, and the safe handling and disposal of these chemicals, Loctite does not recommend field rebuilding of this Dispense Valve.

Loctite Corporation has a Valve Rebuild Program and can ship a rebuilt and tested Dispense Valve to the customer generally within (1) day of receipt of a failed Dispense Valve.

If you have a critical application we recommend that you keep a new or rebuilt valve in stock so that your down time will be limited to the time that it takes to change out a Dispense Valve.

This is an on-off Dispense Valve with no adjustments. Troubleshooting is therefore very basic.

Troubleshooting

Problem	Cause	Proposed Solution
No Product Dispensed.	Check that pressurized product is available at valve inlet port.	Supply Pressurized Product.
	Check that control air is operating and available.	Supply Control Air.
	Nozzle plugged.	Replace Nozzle.
	None of the above.	Replace Dispense Valve.
Product Flow does not shut off.	Check that control air is operating and available.	Supply Control Air at correct pressure.
	Product pressure too great.	Reduce product pressure.
	None of the above.	Replace Dispense Valve.
Product appears at observation port in valve body.	Seal is leaking.	Replace Dispense Valve.

Questions regarding installation, operation, or safety should be addressed to:

Loctite Corporation
 Technical Information Department
 1001 Trout Brook Crossing
 Rocky Hill, Connecticut 06067
 U.S.A.

Telephone: 1-800-LOCTITE (1-800-562-8483) or 860-571-5100.

Dimensional Information:

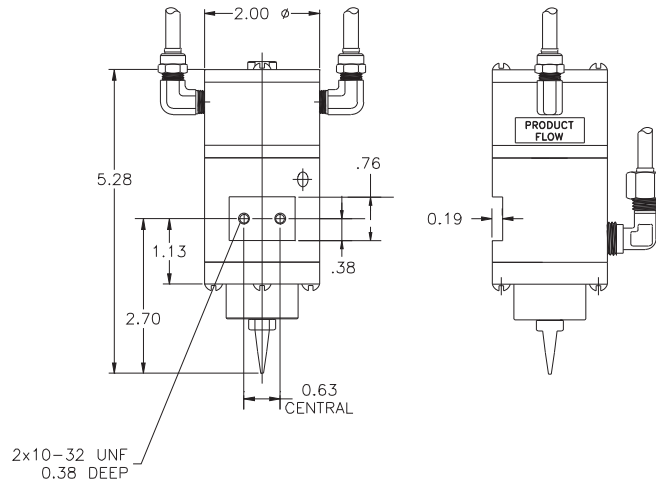

Overall Dimensions Loctite® 986300 Dispense Valve

Weight of Valve with fittings and tubing = 1.3 lb. (0.59 kg)

Length of Control Air Tubing = 4 ft. (1.2 m) each.

Length of Product Tubing = 4 ft. (1.2 m)

Maximum Product Pressure Limit:

Maximum product pressure to this valve shall not exceed 650 psig.

Ratio of Product Pressure to Control Air Pressure:

The ratio is 1 psig control air pressure balances 13 psig product pressure.

For the valve to operate reliably the force available from the air cylinder must be greater than the force available from product pressure.

Loctite recommends that product pressure be less than 10 times control air pressure.

LOCTITE EQUIPMENT WARRANTY

Loctite expressly warrants that all products referred to in this Instruction Manual under Dispense Valve 986300 (hereafter called "Products") shall be free from defects in materials and workmanship. Liability for Loctite shall be limited, at its option, to replacing those Products which are shown to be defective either in materials or workmanship or to credit to the purchaser the amount of the purchase price thereof (plus freight and insurance charges paid therefore by the user). The purchaser's sole and exclusive remedy for breach of warranty shall be such replacement or credit.

A claim of defect in materials or workmanship in any Products shall be allowed only when it is submitted to Loctite in writing within one month after discovery of the defect or after the time the defect should have reasonably have been discovered and in any event, within twelve months after the delivery of the Products to the purchaser. No such claim shall be allowed in respect of Products which have been neglected or improperly stored, transported, handled, installed, connected, operated, used or maintained or in the event of unauthorized modification of the Products including; where products, parts or attachments for use in connection with the Products are available from Loctite, the use of products, parts or attachments which are not manufactured by Loctite.

No Products shall be returned to Loctite for any reason without prior written approval from Loctite. Products shall be returned freight prepaid in accordance with instructions from Loctite.

NO WARRANTY IS EXTENDED TO ANY EQUIPMENT WHICH HAS BEEN ALTERED, MISUSED, NEGLECTED, OR DAMAGED BY ACCIDENT, OR IF THE SYSTEM IS USED TO DISPENSE ANY LIQUID MATERIAL OTHER THAN LOCTITE CORPORATION PRODUCTS.

EXCEPT FOR THE EXPRESS WARRANTY CONTAINED IN THIS SECTION, LOCTITE MAKES NO WARRANTY OF ANY KIND WHATSOEVER, EXPRESS OR IMPLIED, WITH RESPECT TO THE PRODUCTS.

ALL WARRANTIES OR MERCHANTABILITY, FITNESS FOR A PARTICULAR PURPOSE, AND OTHER WARRANTIES OF WHATEVER KIND (INCLUDING AGAINST PATENT OR TRADEMARK INFRINGEMENT) ARE HEREBY DISCLAIMED BY LOCTITE AND WAIVED BY THE PURCHASER.

THIS SECTION SETS FORTH EXCLUSIVELY ALL OF LIABILITY FOR LOCTITE TO THE PURCHASER IN CONTRACT, IN TORT OR OTHERWISE IN THE EVENT OF DEFECTIVE PRODUCTS.

WITHOUT LIMITATION OF THE FOREGOING, TO THE FULLEST EXTENT POSSIBLE UNDER APPLICABLE LAWS, LOCTITE EXPRESSLY DISCLAIMS ANY LIABILITY WHATSOEVER FOR ANY DAMAGES INCURRED DIRECTLY OR INDIRECTLY IN CONNECTION WITH THE SALE OR USE OF, OR OTHERWISE IN CONNECTION WITH, THE PRODUCTS, INCLUDING, WITHOUT LIMITATION, LOSS OF PROFITS AND SPECIAL, INDIRECT OR CONSEQUENTIAL DAMAGES, WHETHER CAUSED BY NEGLIGENCE FROM LOCTITE OR OTHERWISE.



Loctite Americas

1001 Trout Brook Crossing
Rocky Hill, CT 06067-3910

Loctite Corporation

One Northfield Plaza, 5600 Crooks Rd.
Suite 105
Troy, Michigan 48098

Loctite Canada Inc.

2225 Meadowpine Blvd.
Mississauga, Ontario L5N 7P2

Loctite Company de México, S.A. de C.V.

Calzada de la Viga s/n, Fracc. Los Laureles
Loc. Tulpetlac, C.P. 55090
Ecatepec de Morelos, Edo. de México
México

Loctite Brazil

Av. Prof. Vernon Kriebler, 91
06690-11-Itapevi

www.loctite.com

Loctite, Press Pak, and Pump-A-Bead are trademarks of Loctite Corporation, USA.

© Copyright 2000. Loctite Corporation. All rights reserved.

P/N986302 Rev. A – 09/00