



Product Description Sheet

VA15 Diaphragm Valve SS

Item No. 1730181

PRODUCT DESCRIPTION

The Loctite® VA15 Diaphragm Valve is a normally closed, diaphragm valve that provides high resolution stroke adjustment which results in consistent flow control and bubble free, no-drip dispensing for low to medium viscosity Loctite® silicones and other moisture sensitive materials.

PRODUCT FEATURES

- Bubble free, no-drip dispensing
- Compact size and weight
- High resolution stroke adjustment
- Seal-less design
- Fail safe - air to open, spring closed
- Easy cleaning without valve demounting
- Field serviceable
- 316 stainless steel valve chamber
- Easy integration with Loctite® reservoirs and controllers

Technical Data

- Dimensions: 3.1" length x 1" dia. (78.5mm x 26.9mm)
- Weight: 4.8 oz. (135g)
- Pneumatic Supply: 70 - 90 psi (4.8 - 6.2 bar)
- Max Fluid / Pressure: 70 psi (4.8 bar)

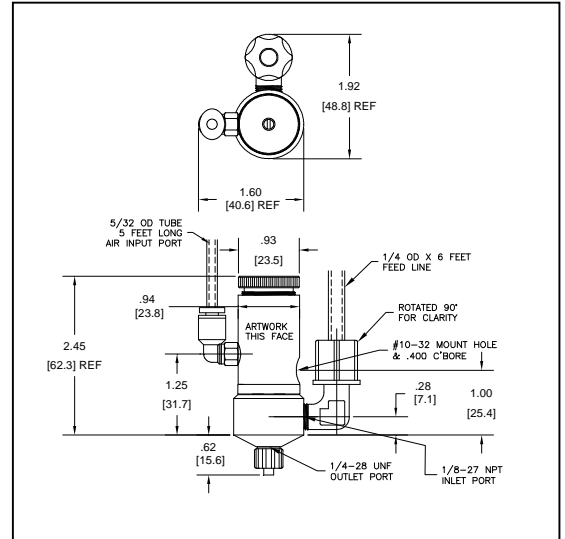

Recommendations

The amount of fluid that flows through the valve is determined by: (1) length of time the valve is open, (2) fluid reservoir pressure, (3) output dispensing tip size, (4) diaphragm stroke and (5) fluid viscosity. The Loctite® 1730181 VA15 Diaphragm Valve may be used for a wide range of applications. Henkel recommends that you test all adhesive applications under simulated or actual end use conditions to ensure the adhesive meets or exceeds all required production specifications.

Note
The data contained herein are furnished for information only and are believed to be reliable. We cannot assume responsibility for the results obtained by others over whose methods we have no control. It is the user's responsibility to determine suitability for the user's purpose of any production methods mentioned herein and to adopt such precautions as may be advisable for the protection of property and of persons against any hazards that may be involved in the handling and use thereof. In light of the foregoing, Henkel Corporation specifically disclaims all warranties expressed or implied, including warranties of merchantability or fitness for a particular purpose, arising from sale or use of Henkel Corporation's products. Henkel Corporation specifically disclaims any liability for consequential or incidental damages of any kind, including lost profits. The discussion herein of various processes or compositions is not to be interpreted as representation that they are free from domination of patents owned by others or as a license under any Henkel Corporation patents that may cover such processes or compositions. We recommend that each prospective user test his proposed application before repetitive use, using this data as a guide. This product may be covered by one or more United States or foreign patents or patent applications.

Trademark usage
Except as otherwise noted, all trademarks in this document are trademarks of Henkel Corporation in the U.S. and elsewhere. © denotes a trademark registered in the U.S. Patent and Trademark Office.

Document # 8903668, Date: 09/19/2012



Henkel Americas
1-800-LOCTITE
www.equipment.loctite.com

Henkel Europe
+49.89.320800.1800
www.henkel.com/industrial

Henkel Asia Pacific
+86.21.2891.8863
www.henkel.com/industrial