

LOCTITE®

EQUIPMENT
Instructions



Loctite® HD10 Pneumatic 300 ml Cartridge Dispenser

Part Number 1714379



1. Unpacking and Inspection

Carefully unpack the Loctite[®] HD10 Pneumatic 300 ml Cartridge Dispenser and examine the items contained in the carton. Inspect the unit for any damage that might have occurred in transit. If such damage has occurred, notify the carrier immediately. Claims for damage must be made by the consignee to the carrier and should be reported to the manufacturer.

1.2 Items supplied

- 1 Pneumatic Dispenser
- 1 Equipment Manual
- 1 Air Line Adapter Fitting With Gasket

1.3 Container Types

This dispenser is suitable to dispense:

- 300 ml cartridges
- 250 ml tubes when item 989347 is purchased separately

2 Technical Data

Pneumatic supply

- Pneumatic quality Filtered 5 µm, oil-free
- Max Inlet pressure 75 psi - Cartridges
 22 psi - Tubes.

Pneumatic connection 1/4-19 BSPP Quick Connect

3 Operating Theory

The cartridge or tube is pneumatically pressurized and product is ejected from the nozzle while the trigger is pressed.

The quantity applied can be adjusted by turning the pressure regulator.

4 Inserting the Cartridge/Tube

- Unscrew the front retaining ring.
- Place the cartridge with the nozzle in the dispenser.
- Screw the tube into the tube adapter 989347 and then assemble it into the dispenser.
- Screw on front retaining ring and tighten.

Caution!

The retaining ring must completely cover the threads to seal the gun.

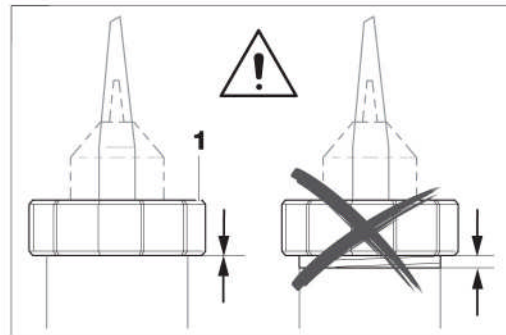
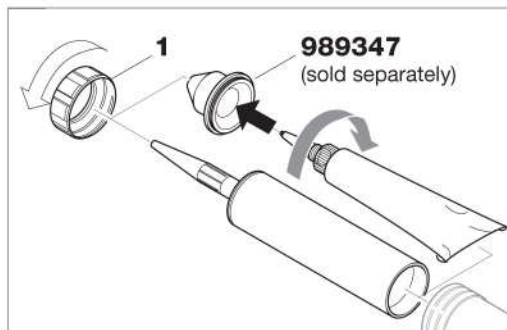

5 Connecting the Unit

- Connect the unit to an external pneumatic supply.

Caution!

When using cartridges, the pneumatic supply must not exceed 75 psi.

When using tubes, the pneumatic supply must not exceed 22 psi.

6 Nozzle Opening

- Cut off the end of the nozzle as necessary. The amount cut off will determine the size of the nozzle opening. It depends on the viscosity of the product and the desired quantity to be applied.

7 Taking Out of Operation

- Disconnect the pneumatic supply from the unit.

8 Care and Use Tips

The Loctite® dispenser is precision crafted and will last a long time if properly maintained.

- Clean carefully after each use. Take care not to let material harden on components.
- Do not immerse the handle. Internal components will be damaged.
- Make sure screws remain intact and tight.

9 Troubleshooting

Type of malfunction	Possible causes	Correction
No or too little product.	<ul style="list-style-type: none">– No pneumatic supply present.– Pressure regulator is not properly adjusted.– Nozzle opening too small.– Hardening in the nozzle.	<ul style="list-style-type: none">• Provide pneumatic supply.• Turn pressure regulator clockwise.• Cut off the end of the nozzle (Section 6).• Replace the nozzle.

10 Warranty

Henkel expressly warrants that all products referred to in this Instruction Manual for 1714379 Loctite® HD10 Pneumatic 300ml Cartridge Dispenser (hereafter called “Products”) shall be free from defects in materials and workmanship. Liability for Henkel shall be limited, as its option, to replacing those Products which are shown to be defective in either materials or workmanship or to credit the purchaser the amount of the purchase price thereof (plus freight and insurance charges paid therefore by the user). The purchaser’s sole and exclusive remedy for breach of warranty shall be such replacement or credit.

A claim of defect in materials or workmanship in any Products shall be allowed only when it is submitted in writing within one month after discovery of the defect or after the time the defect should reasonably have been discovered and in any event, within (12) months after the delivery of the Products to the purchaser. This warranty does not apply to perishable items, such as (diaphragm, tubing, etc.). No such claim shall be allowed in respect of products which have been neglected or improperly stored, transported, handled, installed, connected, operated, used or maintained. In the event of unauthorized modification of the Products including, where products, parts or attachments for use in connection with the Products are available from Henkel, the use of products, parts or attachments which are not manufactured by Henkel, no claim shall be allowed.

No Products shall be returned to Henkel for any reason without prior written approval from Henkel. Products shall be returned freight prepaid, in accordance with instructions from Henkel.

NO WARRANTY IS EXTENDED TO ANY EQUIPMENT WHICH HAS BEEN ALTERED, MISUSED, NEGLECTED, OR DAMAGED BY ACCIDENT.

EXCEPT FOR THE EXPRESS WARRANTY CONTAINED IN THIS SECTION, HENKEL MAKES NO WARRANTY OF ANY KIND WHATSOEVER, EXPRESS OR IMPLIED, WITH RESPECT TO THE PRODUCTS.

ALL WARRANTIES OF MERCHANTABILITY, FITNESS FOR A PARTICULAR PURPOSE, AND OTHER WARRANTIES OF WHATEVER KIND (INCLUDING AGAINST PATENT OR TRADEMARK INFRINGEMENT) ARE HEREBY DISCLAIMED BY HENKEL AND WAIVED BY THE PURCHASER.

THIS SECTION SETS FORTH EXCLUSIVELY ALL OF LIABILITY FOR HENKEL TO THE PURCHASER IN CONTRACT, IN TORT OR OTHERWISE IN THE EVENT OF DEFECTIVE PRODUCTS.

WITHOUT LIMITATION OF THE FOREGOING, TO THE FULLEST EXTENT POSSIBLE UNDER APPLICABLE LAWS, HENKEL EXPRESSLY DISCLAIMS ANY LIABILITY WHATSOEVER FOR ANY DAMAGES INCURRED DIRECTLY OR INDIRECTLY IN CONNECTION WITH THE SALE OR USE OF, OR OTHERWISE IN CONNECTION WITH, THE PRODUCTS, INCLUDING, WITHOUT LIMITATION, LOSS OF PROFITS AND SPECIAL, INDIRECT OR CONSEQUENTIAL DAMAGES, WHETHER CAUSED BY NEGLIGENCE FROM HENKEL OR OTHERWISE.

LOCTITE

Henkel Corporation
One Henkel Way
Rocky Hill, CT 06067-3910

Henkel Canada Corporation
2225 Meadowpine Boulevard
Mississauga, Ontario L5N 7P2

Henkel Capital, S.A. de C.V.
Boulevard Magnocentro No. 8 Piso 2
52760 Huixquilucan, Estado de Mexico

www.loctite.com

® and ™ designate trademarks of Henkel Corporation or its affiliates. ® = registered in the U.S. and elsewhere. © Henkel Corporation, 2009. All rights reserved. Manual P/N: 8903631, Rev A, Date: 08/2012

