



## Loctite® RB10 Rotary Dispense System Part Number 1635546



# Table of Contents

<b>1 Please Observe The Following</b>	<b>3</b>
1.1 Emphasized Sections	3
1.2 For Your Safety	
1.3 Inspection	3
1.4 Items Supplied	4
1.5 Features	4
<b>2 Description</b>	<b>4</b>
2.1 Control Panel	4
2.2 Integration Panel	5
<b>3 Technical Data</b>	<b>5</b>
<b>4 Installation</b>	<b>6</b>
<b>5 Operation</b>	<b>7</b>
5.1 Theory of Operation	7
5.2 Controller Set Up	8
5.3 Mounting Plate	10
5.4 Valve and Syringe Dispenser Integration	11
5.4.1 Light Cure, CA and VA10 Valves	11
5.4.2 Stationary Valves	11
5.4.3 Syringe or Cartridge Dispensing	12
5.5 Slide Adjustment	13
5.6 Reservoir Low Level Control	13
<b>6 Troubleshooting</b>	<b>14</b>
<b>7 Care and Maintenance</b>	<b>14</b>
<b>8 Accessories</b>	<b>15</b>
<b>9 Wiring Schematic</b>	<b>15</b>
<b>10 Warranty</b>	<b>16</b>

---

# 1 Please Observe The Following

---

## 1.1 Emphasized Sections

### **Warning!**

Refers to safety regulations and requires safety measures that protect the operator or other persons from injury or danger to life.

### **Caution!**

Emphasizes what must be done or avoided so that the unit or other property is not damaged.

### **Notice:**

Gives recommendations for better handling of the unit during operation or adjustment as well as for service activities.

## 1.2 For Your Safety

 For safe and successful operation of the unit, read these instructions completely. If the instructions are not observed, the manufacturer can assume no responsibility.

 Do not expose the connecting cable to heat, oil, or sharp edges.

 Make sure the Unit stands stable and secure.

 Use only original equipment replacement parts.

 Always disconnect the power supply before servicing the unit.

 Observe general safety regulations for the handling of chemicals such as Loctite<sup>®</sup> adhesives and sealants. Observe the manufacturer's instructions as stated in the Material Safety Data Sheet (MSDS).

 *While under warranty, the unit may be repaired only by an authorized Loctite service representative.*

## 1.3 Unpacking and Inspection

Carefully unpack the Loctite<sup>®</sup> RB10 Rotary Dispense System and examine the items contained in the carton. Inspect the unit for any damage that might have occurred in transit. If such damage has occurred, notify the carrier immediately. Claims for damage must be made by the consignee to the carrier and should be reported to the manufacturer.

## 1.4 Items supplied

- (1) Rotary Dispense System
- (1) Foot Switch
- (1) Power Supply with Cord
- (1) Instruction Manual

## 1.5 Features

- Integrated Solution – plug and play with Loctite valves, reservoirs, and Syringe Systems
- Digital Control of rotation, dispense start, dispense stop and delays
- Adjustable height, position, angle of dispense, and advance slide speed
- Reservoir low-level interface with cycle interruption and display message
- Part position sensing allows orientation of adhesive bead start and end
- Threaded and non threaded mounting holes for fixtures
- Operator lockout for supervisory control of settings
- Dispense valve and syringe mounting hardware available

---

## 2 Description

---

The Loctite® RB10 Rotary Dispense System is a fully integrated system used for dispensing adhesives onto parts in a circular or arc pattern. It will control a syringe system, cartridge, or dispense valve without requiring a separate valve controller. Internally synchronized operation of an advancing slide, turntable, and dispense timer makes for easy and repetitive placement of the adhesive. The set-up is simple, using only preset distance and rotation speed adjustment. No complex programming required!

### 2.1 Control Panel (Front of Controller)



## 2.2 Integration Panel (Back of Controller)

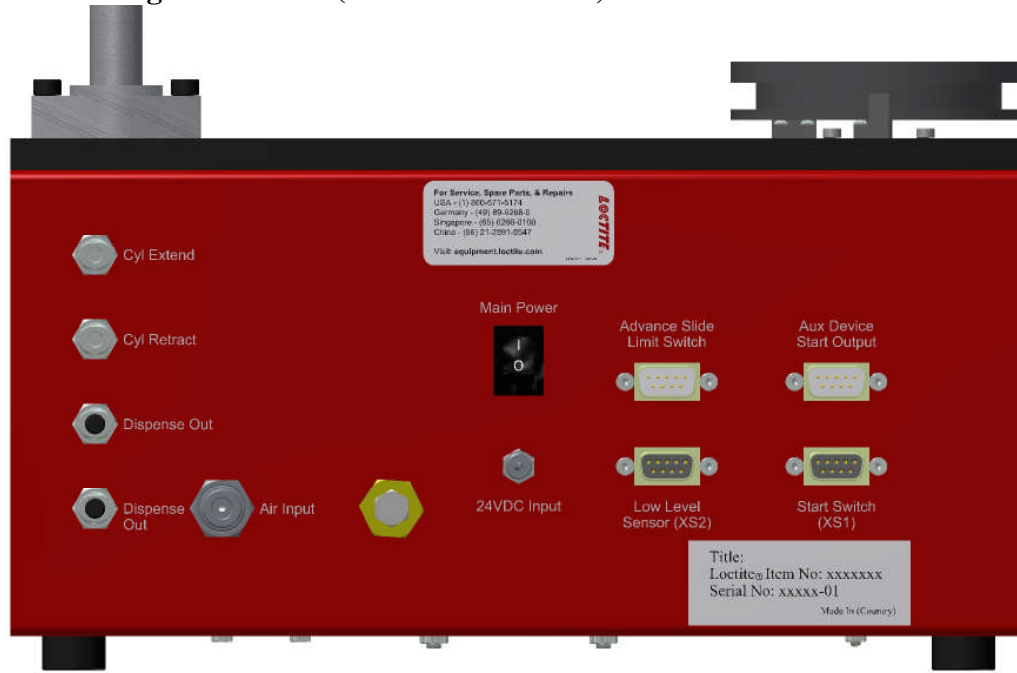

## 3 Technical Data

Attribute		Value
Dispense Pattern		Circles or Arcs in a Circular Pattern
Slide Stroke		0 – 2” (0 – 50 mm)
Rotation Range		0 – 999 Degrees
Rotation Speed		5 to 55 RPM
Maximum Part Height		12” (305 mm)
Maximum Part Diameter		18” (475 mm)
Maximum Part Weight		6 lbs (2.7 kg)
Dimensions	Width	12” (305 mm)
	Depth	8¾” (222 mm)
	Height	22” (559 mm) Minimum 25” (635 mm) Maximum
Weight		18.5 lb (8.4 kg)
Air Input*		Clean, dry air not to exceed 125 psig (8.5 bar), and filtered with a maximum of 50 micron
Power		Supply: 110 – 230 V / 50 – 60 Hz Internal: 24 VDC

\* If the required air quality is not available, install a Loctite® filter regulator. In the US order a 5 µm filter using part number 985397. In Europe or Asia, order a 10 µm filter using part number 97120.

---

## 4 Installation

---

**!** Before using the tool for the first time check it carefully for signs of external damage. If any shipping damage is found DO NOT USE THE TOOL - return it to your supplier immediately.

1. Assemble the stand to the main control unit by attaching the vertical mounting pole (the longer bar supplied) into the vertical support bracket on the control of the unit. Tighten the M4 from the side of the support bracket to secure the vertical mounting pole.
2. Assemble the slide assembly to the stand.
3. Secure the slide assembly by tightening the M6 screw on the slide assembly bracket.
4. Connect the Cylinder Extend and Cylinder Retract Air hoses to the Cyl Extend and Cyl Retract ports on the back of the unit.
5. Connect the Advance Slide Cable to the Advance Slice Limit Switch connector of the back of the unit.
6. Plug the power adapter with cord into the “24VDC” input on the back of the controller and into the wall socket.

 **Notice:** The power adapter has auto ranging power function that can be used with either 110 or 220V and 50 or 60 Hz.

7. Connect the foot switch, or PLC start signal cable, to the “Start Switch XS1” connector on the back of the controller.
8. Connect the air input line to the Air Input fitting using 6mm O.D. pneumatic tubing (not supplied).
9. Turn on the local air supply. This must be a minimum of 80 psi and a maximum of 125 psi.



**Warning!** When the air is connected, the slide may retract. Be sure to keep your hands and other objects clear of the slide before connecting the air.



**Caution!** Clean, dry, filtered air must be used. If it is not, the solenoids in the controller will be fouled over time. If the required air quality is not achieved, install a Loctite<sup>®</sup> filter regulator. In the US order a 5 µm filter using Part Number 985397. In Europe or Asia, order a 10 µm filter using Part Number 97120.

---

## **5 Operation**

---

### **5.1 Theory of Operation**

1. After turning on the unit, press the footswitch or ENTER button to activate the system.
2. The advancing slide will start to extend and the rotary disc will start to rotate with the preset speed.
3. The advancing slide will activate the proximity sensor when it reaches the preset position.
4. The start of disc rotation, or the locator pin reaching the proximity sensor (in homing mode), will trigger the rotation distance counter and the unit will start to dispense for preset dispensing time. Use of the homing mode ensures that each dispense start will be at the same point.
5. After the dispensing timer has reached the preset dispense time, the advancing slide will retract and the rotary disc will be stopped.
6. The dispense start position “DS Position” determines how far the disc will rotate before starting to dispense. This ensures the rotation has reached a constant speed when dispense begins.
7. The “Off Delay” feature determines how long the disc will continue to rotate after the dispense has stopped. This allows product remaining on the tip of the dispenser to be transferred to the part after the dispense stops, prior to retracting.
8. The reservoir low level sensor setting disables the start signal and displays “Alarm: RESERVOIR LOW LEVER.” The Low Level state can be manually overridden allowing the system to cycle by pressing the ENTER button, however the alarm will continue to be displayed and the system will not cycle using a footswitch or PLC.

## 5.2 Controller Set Up

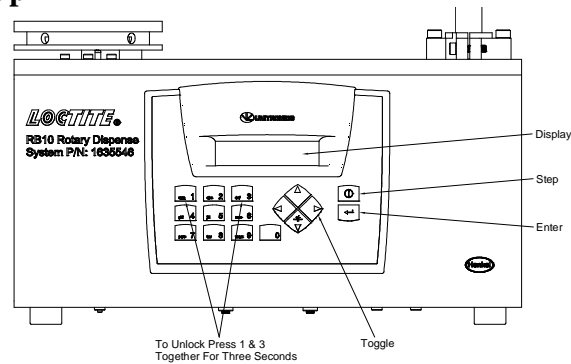

**Notice:** Upon start-up, the system will be in **operator lockout mode**. To unlock the controller, press 1 & 3 simultaneously for three seconds. To return to operator lockout mode simply turn system off; all settings will be stored. The system will always start in operator lockout mode.

The Display at Power ON will be:

**READY**  
⇒ **press START**

Unlock the controller by pressing 1 & 3 simultaneously for three seconds. The Display will still be:

**READY**  
⇒ **press START**

Press Step and the Display will change to

**LOW LEVEL SENSOR**  
⇒ **enabled**

To disable the low level sensor, press the Toggle Arrow then press ENTER

Press Step and the Display will change to

**HOMING**  
⇒ **OFF**

To enable homing, press the Toggle Arrow then press ENTER



Press Step and the Display will change to

**Speed: 10 RPM**

**Dist: 90 deg**

To change the speed (revolutions per minute), type the desired speed with key pad, then press ENTER

To change the distance (in degrees) that product will dispense, type the desired distance using the key pad, then press ENTER

 **Notice:** The distance setting determines how far the rotation motor receives power and is intended to be an aid in initial set up not as an absolute setting of rotation. Higher speed setting and heavier part weights create momentum that will cause mounting plate to carry beyond the preset degrees in a repeatable fashion.

Press Step and the Display will change to

**DS Position: 0**

**OFF Delays: 0.0**

To set the Dispense Start position (how far the disc will rotate before dispense starts) type the desired distance, in degrees, then press ENTER

To set the desire off delay (how long in seconds the disc will rotate after dispense stops, type the desired time then press ENTER

Press Step and the Display will change to

**READY**

⇒ **press START**

You have completed Controller Set Up. The Controller will remain unlocked until power is turned off.

 **Notice:** The settings can be tested without exiting mode by pressing 1 & ENTER. This will start a cycle.

Changes can be made by pressing STEP key until you get to the desired parameter. To save the changes and exit Program Mode, simply turn the power off.

### 5.3 Mounting Plate

The drawing below shows the RB10 Rotary Dispense System mounting plate. This through holes on the mounting plate can be used for fixture alignment and the threaded 1/4-20 holes can be used to secure the fixture.

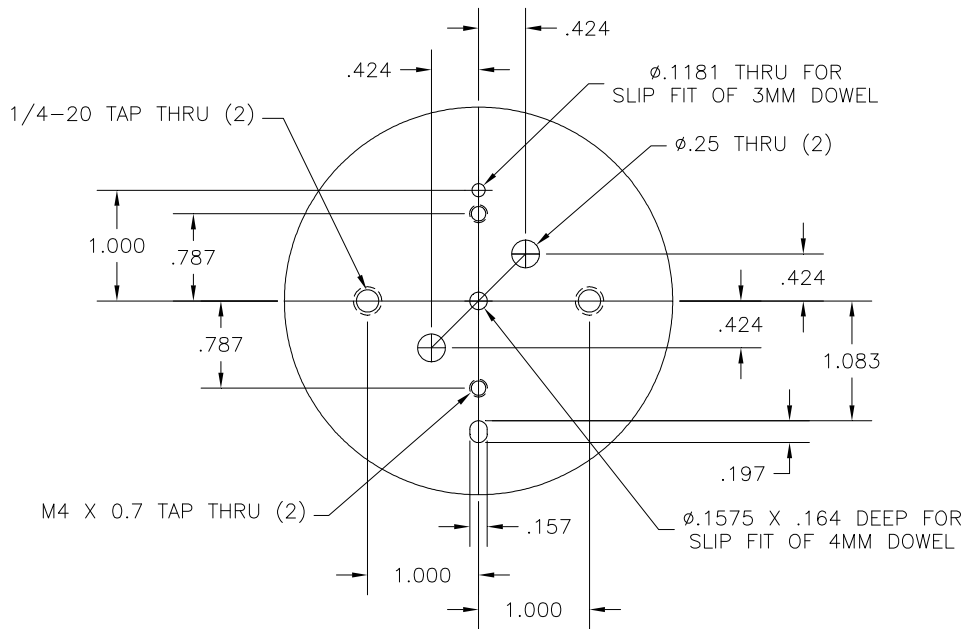

## 5.4 Valve and Syringe Dispenser Integration

The Loctite® RB10 Rotary Dispense System is designed to be used with syringes, cartridges, single acting product valves and double acting product valves. To integrate these dispense systems please use the following instructions:

### 5.4.1 98009 Light Cure, 98013 Cyanoacrylate and VA10 Micro Dispense Valves

Must be purchased separately:

- Mounting Rail – P/N 98328
  - Mounting Bracket – P/N 98326
  - Mounting Bracket – P/N 1638885
  - Pressure Reservoir
    - P/N 982726, Bond-A-Matic reservoir, 0-15 psi for use with adhesives with <3,000 cPs viscosity.
    - P/N 982727, Bond-A-Matic reservoir, 0-100 psi for use with adhesives with >3,000 cPs viscosity.
1. Insert the 4mm tube plug in the upper “Dispense Out” (normally closed) connection.
  2. Add the dispense tip onto the valve.
  3. Secure the mounting rail to the advance slide using the M4 screws provided.
  4. Slide the mounting bracket over the mounting rail on the slide assembly and secure it in position with the white nylon thumbscrew.
  5. Manually pull the slide down to the fully extended position.
  6. Slide the valve into the mounting bracket and secure it using the black thumbscrews.
  7. Adjust the height and position of the mounting bracket to the approximate position desired. To adjust the position, loosen the screws on the clamp blocks counter clockwise, set the position and then secure by turning the screws clockwise.
- !** **Caution!** It is important to ensure that the dispense tip will not crash with the mounting plate, fixture or part. Please ensure that the height is set to avoid crashes.
8. Connect the air inlet on the valve to the upper “Dispense Out” on the back of the controller using the 4mm air line tubing supplied with the valve.

### 5.4.2 97113 and 97114 Stationary Valves

Must be purchased separately:

- Mounting Rail – P/N 98328
  - Mounting bracket – P/N 98327
  - Pressure Reservoir
    - P/N 982726, Bond-A-Matic reservoir, 0-15 psi for use with adhesives with <3,000 cPs viscosity.
    - P/N 982727, Bond-A-Matic reservoir, 0-100 psi for use with adhesives with >3,000 cPs viscosity.
    - P/N 982720, Bond-A-Matic reservoir, 0-15 psi, with low level sensor.
    - P/N 982723, Bond-A-Matic reservoir, 0-100 psi, with low level sensor.
1. Using 4mm tubing supplied with the valve, connect both the upper “Dispense Out” (normally closed) and lower “Dispense Out” (normally open) connections from the valve to the back of the controller.
  2. Add the dispense tip to the valve.
  3. Secure the mounting rail to the advance slide using the screws provided with the bracket.
  4. Slide the mounting bracket over the mounting rail on the slide assembly and secure it in position with the white nylon thumbscrew.
  5. Manually pull the slide down to the fully extended position.
  6. Slide the valve into the mounting bracket and secure it using the black thumbscrews.

- Adjust the height and position of the mounting bracket to the approximate position desired. To adjust the position, loosen the screws on the clamp blocks counter clockwise, set the position and then secure by turning the screws clockwise.

**! Caution!** It is important to ensure that the dispense tip will not crash with the mounting plate, fixture or part. Please ensure that the height is set to avoid crashes.

#### 5.4.3 Syringe or Cartridge Dispensing

Must be purchased separately:

Accessory	Loctite Part Number			
	Syringe			Cartridge
	10 ml	30 ml	55 ml	300 ml
Syringe Dispenser (Required)	883976	883976	883976	883976
3 ¾" Mounting Rail (required)	98328	98328	98328	98328
Mounting Bracket (required)	98316	98316	98316	98318
Syringe Adapter (required)	98320	N/A	N/A	N/A
Dispense Tip Connectors (required)	N/A	N/A	N/A	982644 97233
Clear Syringe Barrel Kit (optional)	97207	97244	98314	N/A
Black Syringe Barrel Kit (optional)	97263	97264	98315	N/A

- Refer to the operation manual of the syringe dispenser for setup instructions.
- Connect the syringe dispenser to the system with XS2 cable part number 989432 (need to purchase separately).
- Insert the 4mm tube plug in the both the upper "Dispense Out" (normally closed) and lower "Dispense Out" (normally open) connections.
- Add the dispense tip onto the syringe or cartridge. For some cartridges, it will be necessary to install the cartridge adapter Part No. 982644 and luer lock adapter Part No. 97233 before connecting the dispense tip.
- Secure the mounting rail to the advance slide using the M4 screws provided.
- Slide the mounting bracket over the mounting rail on the slide assembly and secure it in position with the white nylon thumbscrew.
- Manually pull the slide down to the fully extended position.
- Adjust the height and position of the mounting bracket to the approximate position desired. To adjust the position, loosen the screws on the clamp blocks counter clockwise, set the position and then secure by turning the screws clockwise.
- Slide the syringe or cartridge into the mounting bracket and secure it using the black thumbscrews.

**! Caution!** It is important to ensure that the dispense tip will not crash with the mounting plate, fixture or part. Please ensure that the height is set to avoid crashes.

## 5.5 Slide Adjustments

The speed controls on the slide can be adjusted to increase or decrease the speed that the slide advances or retracts. The speed should be set so that the slide moves at a controlled rate. This may need to be adjusted to account for more weight on the slide or to change the slide advance / retract time.

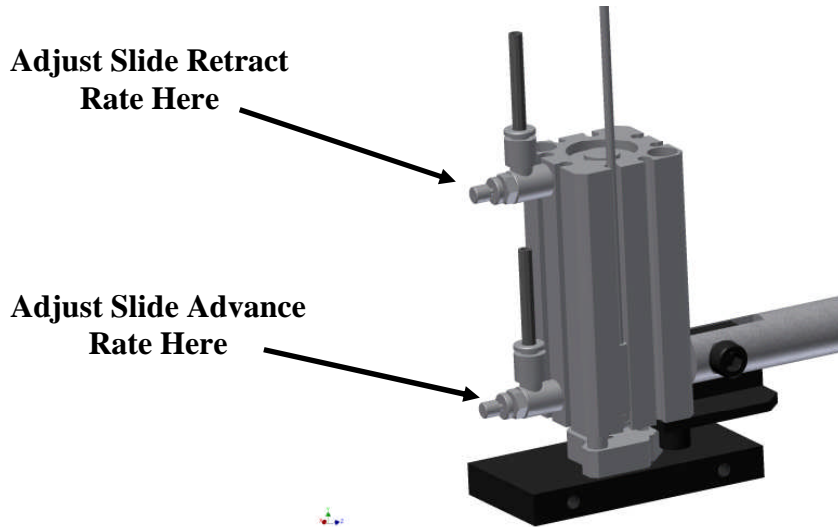

## 5.6 Reservoir Low Level Control

### 5.6.1 Disabling the Low Level Function

1. In Set Up mode (see section 5.2) set Low Level Sensor to “Disabled.”

### 5.6.2 Enabling the Low Level Function

1. Connect the 9 pins D-sub female (XS2 Low Lev) cable to the Low Level Sensor (XS2) Connector.
2. In Set Up mode (see section 5.2) set Low Level Sensor to “Enabled.”

 **Notice:** When a Reservoir Low Level state occurs during a cycle, the cycle will complete and the display will read “Alarm: RESERVOIR LOW LEVER.” The Low Level setting disables the start signal.

 **Notice:** In run mode, the Low Level state can be manually overridden allowing the system to cycle by pressing the ENTER button. Pressing the ENTER button will cycle the unit, however the alarm will continue to be displayed and the system will not cycle using a footswitch or PLC.

 **Notice:** In Set Up mode, pressing the ENTER button will clear the Low Level state for one cycle fully disabling the alarm and allowing use of the foot switch or PLC.

3. After eliminate the Low Level state, pressing ENTER will run another cycle and reset the Low Level alarm. The Low Level alarm can also be re-set by turning the system off after eliminating the Low Level state.

---

## 6 Troubleshooting

---



**Before proceeding with any repair or maintenance operation disconnect the tool from the main electricity supply.**

Symptom	Possible Corrective Action(s)
The "POWER" does not turn "ON"	Plug the unit in Set the "POWER" button "ON" position
The system will not pressurize.	1. Confirm that the "Air Input" is connected 2. Confirm that the air supply is 80-125 psi. 3. Confirm that the "Dispense Out" fittings are properly connected or plugged.
Mounting plate rotates further than distance setting.	Higher speeds and part weights will cause the mounting plate to carry beyond the distance setting. The distance setting is intended for reference purposes only as an aid to initial set up.
The slide is advancing or retracting too fast or slow.	The slide advance and retract rate should be set so that the slide moves at a controlled rate. The factory default is for the full slide stroke to take approximately 0.5 seconds. If this needed to be adjusted, see Section 5.5 for instructions.
The disc will not stop rotating and the display reads "Homing..." OR Display read "Dispenser in wait"	1. Confirm that the air supply is pressurized and at 80-125 psi. 2. Confirm that the advancing slide moves down when the cycle starts.
The "Reservoir Low Level Alarm Light" (1) does not work	1. Check that XS2 cable between the reservoir and the RB10 is connected. 2. Check that Low Level Sensor Switch setting is in the "enabled" state.
The dispense valve does not dispense	1. Check the pneumatic connection. 2. Check the pneumatic supply.

---

## 7 Care and Maintenance

---

### 7.1 Care

This unit should be stored in a level, dry location at ambient condition out of direct sunlight.

### 7.2 Maintenance

To minimize wear of the slide assembly, periodically apply several drops of light machine oil to the slide rods, manually advance and retract the slide several times then remove the excess lubricant using a rag.



**Warning!** Be sure to release the pressure and shut of the pressure supply before lubricating the slide rods.



**Notice:** Clean, dry, filtered air must be used. If it is not, the solenoids on the controller will be fouled over time.



**Notice:** If the required air quality is not achieved, install a Loctite® filter regulator. In the US order a 5 µm filter using Part Number 985397. In Europe or Asia, order a 10 µm filter using Part Number 97120.

## 8 Accessories

Syringe Dispenser Accessories:

Accessory	Loctite Part Number			
	Syringe			Cartridge
	10 ml	30 ml	55 ml	300 ml
Syringe Dispenser (Required)	883976	883976	883976	883976
3 3/4" Mounting Rail (required)	98328	98328	98328	98328
Mounting Bracket (required)	98316	98316	98316	98318
Syringe Adapter (required)	98320	N/A	N/A	N/A
Dispense Tip Connectors (required)	N/A	N/A	N/A	982644 97233
Clear Syringe Barrel Kit (optional)	97207	97244	98314	N/A
Black Syringe Barrel Kit (optional)	97263	97264	98315	N/A

Additional Mounting Hardware:

Description	Item Number
98009 and 98013 Valve Mounting Bracket	98326
97113 and 97114 Valve Mounting Bracket	98327
VA10 Valve Mounting Bracket	1638885
3 3/4 inch mounting rail with two cap screws	98328
8 3/4 inch mounting rail with two cap screws	98329
C Rail Kit for Mounting Brackets	98331
986300 Poppet Valve Mounting Bracket Kit	98406
98084 or 98520 Valve Mounting Bracket Kit	98441

## 9 Wiring Schematic

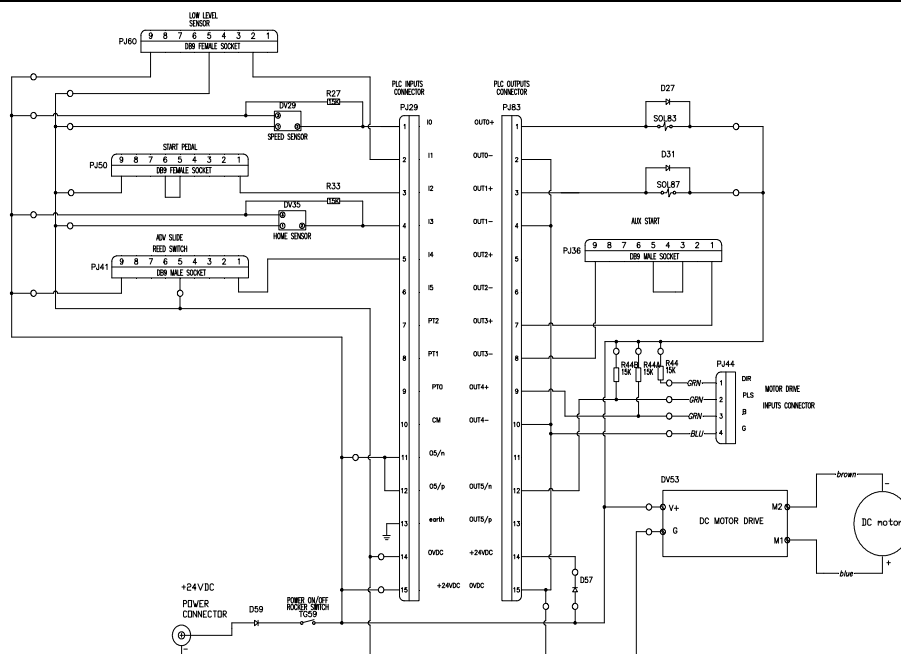

---

## 10 Warranty

---

Henkel expressly warrants that all products referred to in this Instruction Manual for 1635546 Loctite® RB10 Rotary Dispense System (hereafter called “Products”) shall be free from defects in materials and workmanship. Liability for Henkel shall be limited, as its option, to replacing those Products which are shown to be defective in either materials or workmanship or to credit the purchaser the amount of the purchase price thereof (plus freight and insurance charges paid therefor by the user). The purchaser’s sole and exclusive remedy for breach of warranty shall be such replacement or credit.

A claim of defect in materials or workmanship in any Products shall be allowed only when it is submitted in writing within one month after discovery of the defect or after the time the defect should reasonably have been discovered and in any event, within (12) months after the delivery of the Products to the purchaser. This warranty does not apply to perishable items, such as fuses. No such claim shall be allowed in respect of products which have been neglected or improperly stored, transported, handled, installed, connected, operated, used or maintained. In the event of unauthorized modification of the Products including, where products, parts or attachments for use in connection with the Products are available from Henkel, the use of products, parts or attachments which are not manufactured by Henkel, no claim shall be allowed.

No Products shall be returned to Henkel for any reason without prior written approval from Henkel. Products shall be returned freight prepaid, in accordance with instructions from Henkel.

**NO WARRANTY IS EXTENDED TO ANY EQUIPMENT WHICH HAS BEEN ALTERED, MISUSED, NEGLECTED, OR DAMAGED BY ACCIDENT.**

**EXCEPT FOR THE EXPRESS WARRANTY CONTAINED IN THIS SECTION, HENKEL MAKES NO WARRANTY OF ANY KIND WHATSOEVER, EXPRESS OR IMPLIED, WITH RESPECT TO THE PRODUCTS.**

**ALL WARRANTIES OF MERCHANTABILITY, FITNESS FOR A PARTICULAR PURPOSE, AND OTHER WARRANTIES OF WHATEVER KIND (INCLUDING AGAINST PATENT OR TRADEMARK INFRINGEMENT) ARE HEREBY DISCLAIMED BY HENKEL AND WAIVED BY THE PURCHASER.**

**THIS SECTION SETS FORTH EXCLUSIVELY ALL OF LIABILITY FOR HENKEL TO THE PURCHASER IN CONTRACT, IN TORT OR OTHERWISE IN THE EVENT OF DEFECTIVE PRODUCTS.**

**WITHOUT LIMITATION OF THE FOREGOING, TO THE FULLEST EXTENT POSSIBLE UNDER APPLICABLE LAWS, HENKEL EXPRESSLY DISCLAIMS ANY LIABILITY WHATSOEVER FOR ANY DAMAGES INCURRED DIRECTLY OR INDIRECTLY IN CONNECTION WITH THE SALE OR USE OF, OR OTHERWISE IN CONNECTION WITH, THE PRODUCTS, INCLUDING, WITHOUT LIMITATION, LOSS OF PROFITS AND SPECIAL, INDIRECT OR CONSEQUENTIAL DAMAGES, WHETHER CAUSED BY NEGLIGENCE FROM HENKEL OR OTHERWISE.**

**LOCTITE**

**Henkel Corporation**  
One Henkel Way  
Rocky Hill, CT 06067-3910

**Henkel Canada Corporation**  
2225 Meadowpine Boulevard  
Mississauga, Ontario L5N 7P2

**Henkel Capital, S.A. de C.V.**  
Calzada de la Viga s/n Fracc. Los Laureles  
Loc. Tulpetlac, C.P. 55090  
Ecatepec de Morelos, Edo. de México

**Henkel Corporation**  
**Automotive / Metals HQ**  
32100 Stephenson Hwy.  
Madison Heights, MI 48071

**Henkel Ltda.**  
Rua Karl Huller, 136 – Jd.  
Canhema 09941-410  
Diadema/SP, Brazil

[www.loctite.com](http://www.loctite.com)

® and ™ designate trademarks of Henkel Corporation or its affiliates. ® = registered in the U.S. and elsewhere. © Henkel Corporation, 2009. All rights reserved. Data in this operation manual is subject to change without notice.  
Manual P/N: 8903134, Rev A, Date: 08/13/2012

