

**LOCTITE**<sup>®</sup>

Maintain, Repair, Rebuild, Protect

# Solutions for Mines and Quarries



**Henkel** Excellence is our Passion

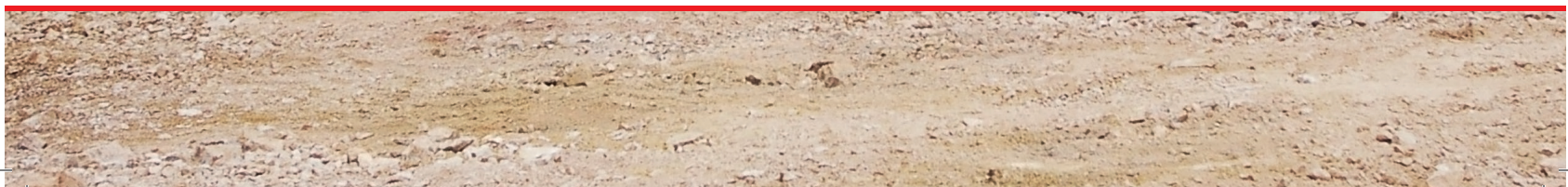



# Henkel. Complete Solutions for Your Entire Mining Operation.

Repair, rebuild, maintain and protect your assets

**Maximizing production and preventing unplanned downtime** are critical in the mining industry. At Henkel — the leading solution provider for adhesives, sealants and functional coatings worldwide — we understand the challenges you face because we know the mining industry inside and out.

With more than **50 years of experience** in mining, we'll help you keep your plants and equipment in top operating condition. Our **LOCTITE brand** adhesives are known around the world for reliability and quality.

Let us show you how Henkel and our LOCTITE brand can help you **reduce costs, increase reliability, and improve efficiency.**

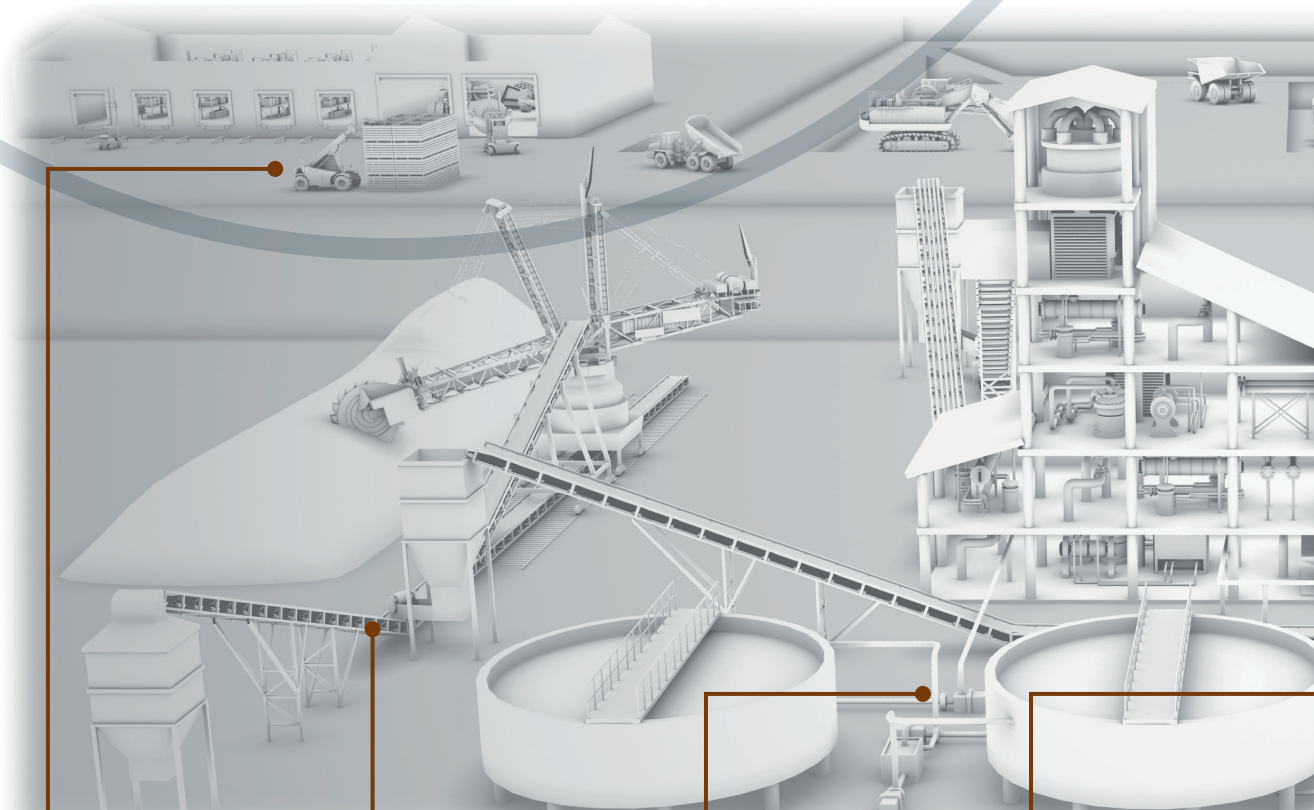

**TRUCK SHOP/MOBILE EQUIPMENT:**  
Lubricants, cleaners and general maintenance chemical solutions

**CONVEYOR BELT SYSTEMS:**  
Fast rubber repairs

**PIPES, DUCTS AND ELBOWS:**  
Abrasion and corrosion protection

**FLOTATION CELLS:**  
Abrasion and corrosion protection, internal liner repairs

# Why Henkel?

As the leading solution provider for adhesives, sealants, and functional coatings worldwide, we work as a partner with the mining industry.

## COMPLETE PRODUCT PORTFOLIO

A full range of solutions for the mining industry.

## INNOVATION

Solutions developed with our customers to help solve their toughest challenges.

## TECHNICAL EXPERTISE

Engineering support to help you improve your operations.

## GLOBAL REACH

Our products and services are available worldwide.

## TRAINING

On-site maintenance workshops to prevent equipment failure.

## INDUSTRY EXPERTISE

We work throughout the mining value chain, from exploration to refining and transportation.

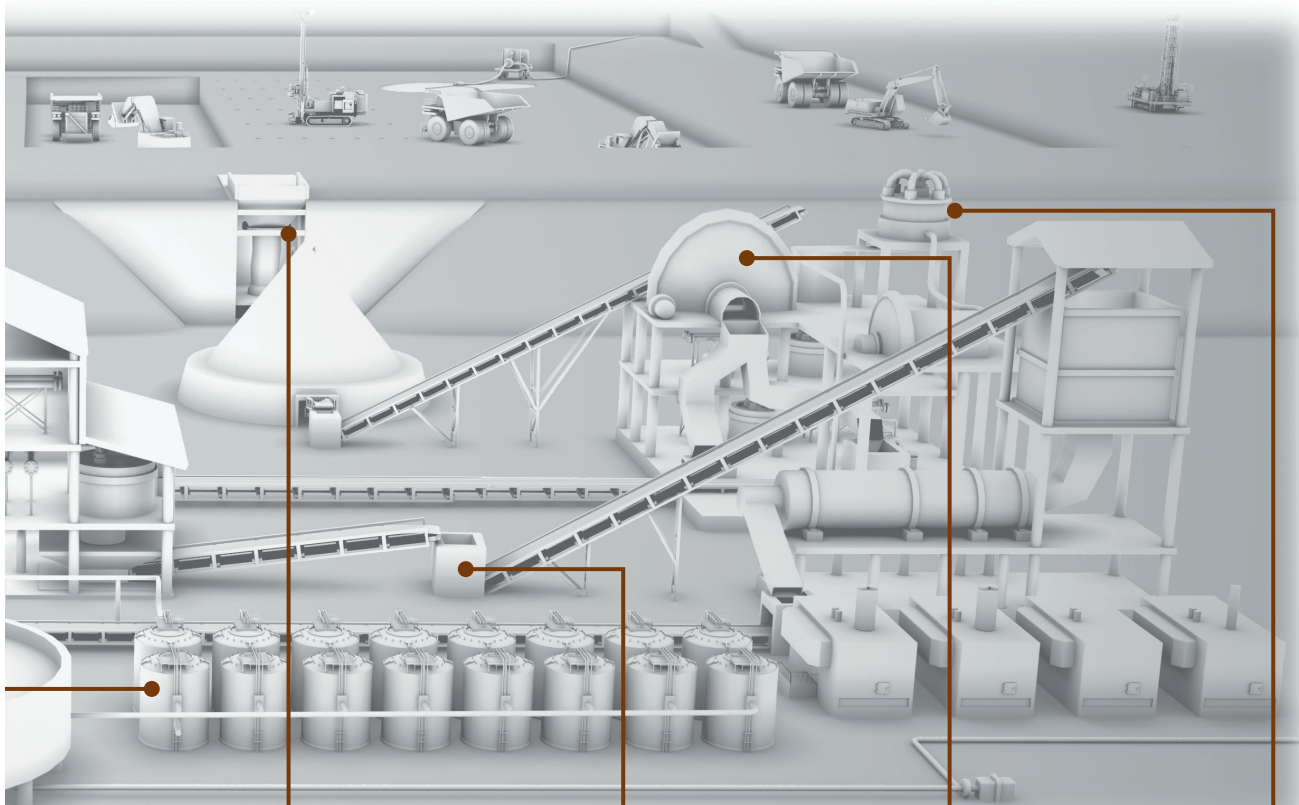

**GYRATORY/CONE CRUSHERS:**  
Impact resistant epoxy backing compounds

**CHUTES:**  
High impact adhesive solutions to bond ceramic tiles

**BALL MILLS:**  
Fast cure/high impact abrasion-resistant Solutions

**HYDROCYCLONES:**  
Fast cure/high impact abrasion-resistant solutions

# Put Henkel's expertise to work on some of your toughest challenges:

## YOUR CHALLENGES

### EFFICIENCY

Shorter equipment life and reduced efficiency due to wear

### RELIABILITY

Chronic equipment failures, reduced performance

## HENKEL SOLUTIONS

LOCTITE wear prevention products extend equipment life to increase Mean Time Between Failures (MTBF)

LOCTITE products to prevent loosening, leaks, corrosion and other problems, reducing Mean Time to Repair (MTTR) and MTBF

## BENEFITS

- Increased uptime
- Improved efficiency

- Prevent unscheduled downtime
- Increase reliability





- Improving plant *efficiency*
- Increasing equipment *reliability*
- Strengthening plant *safety*
- Reducing *costs*

### SAFETY

Safety hazards from unreliable machinery, leaks and other failures

Training on use of LOCTITE products to improve reliability and reduce downtime; plant surveys to identify repair improvements

- Improved plant safety
- Reduced downtime

### COSTS

Equipment subject to wear and corrosion; replacement costs affecting profitability

LOCTITE products to rebuild and repair equipment; in-situ repair without interruption of operations

- Increased asset life
- Reduced replacement costs



## Broad Product Range

From threadlockers and thread sealants to protective coatings, our LOCTITE brand provides solutions for every challenge.

Visit [henkelna.com/mining](http://henkelna.com/mining)

# Henkel. Understanding your equipment. Solving your specific problems.

## PRIMARY CRUSHER

YOUR CHALLENGE	OUR SOLUTION	BENEFITS
Fill the gap between housing and manganese steel liners to avoid premature failures	<b>BACKING COMPOUND:</b> Apply LOCTITE PC 9020 to replace smelted zinc and lower-performance products	<ul style="list-style-type: none"> <li>• Safer for end-users</li> <li>• Unique color-change mix identifies when the product is ready to pour</li> <li>• Higher compressive/ impact resistance increases life of liners</li> </ul>
Fill the gap between concrete base and sole metal plate to avoid disalignment	<b>MARINE CHOCKING:</b> Apply LOCTITE Marine Chocking	<ul style="list-style-type: none"> <li>• Highest compression strength</li> <li>• Easy to mix and pour</li> <li>• Avoid premature failure</li> </ul>

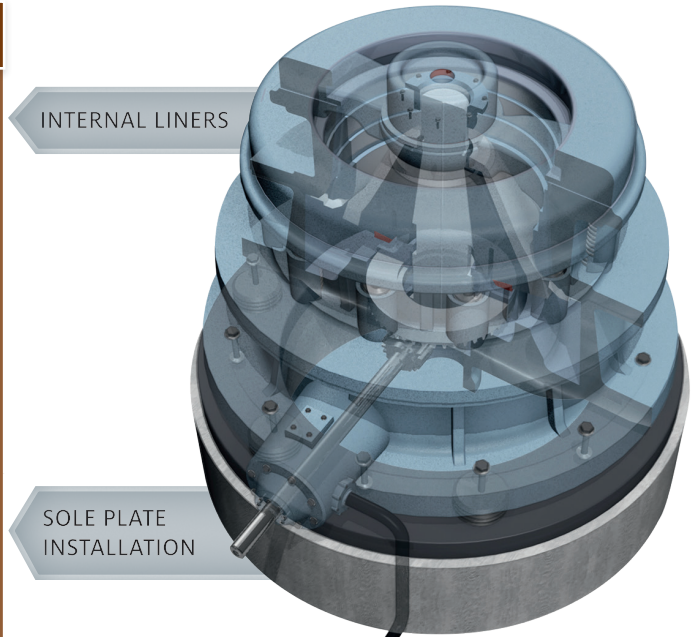



Downtime in a mine's processing plant can mean loss of hours and money. The following pages show some common problem areas and Henkel solutions.



## CHUTES

YOUR CHALLENGE	OUR SOLUTION	BENEFITS
Protect the gap between ceramic tiles in chutes	<b>ABRASION PROTECTION:</b> Apply LOCTITE High Impact Wearing Compound	<ul style="list-style-type: none"> <li>• Extend the life of the chute</li> <li>• Avoid tile release</li> </ul>

TILE INSTALLATIONS



## CONVEYOR BELT SYSTEMS

YOUR CHALLENGE	OUR SOLUTION	BENEFITS
Repair damaged areas on rubber	<b>ABRASION PROTECTION:</b> Apply new LOCTITE Rapid Rubber Repair	<ul style="list-style-type: none"> <li>• Reduce MTTR</li> <li>• Extend the life of the equipment</li> <li>• Avoid major failures</li> </ul>

RAPID RUBBER REPAIR



## Henkel Engineering Services

Detailed in-plant surveys that identify potential cost savings and maintenance improvements.

Call 1-800-LOCTITE (562.8483) or visit [henkelna.com](http://henkelna.com)

# Our LOCTITE solutions provide:

Surface protection • Abrasion resistance • Cost savings

## SAG AND BALL MILLS

YOUR CHALLENGE	OUR SOLUTION	BENEFITS
Protect damaged areas over rubber/metal surfaces	<b>ABRASION PROTECTION:</b> Apply LOCTITE Fast Cure Wearing Compound/High Impact Wearing Compound	<ul style="list-style-type: none"> <li>• Reduce MTRR</li> <li>• Extend MTBF</li> <li>• Avoid a major shutdown; repairs can be done on regular planned shutdowns</li> </ul>

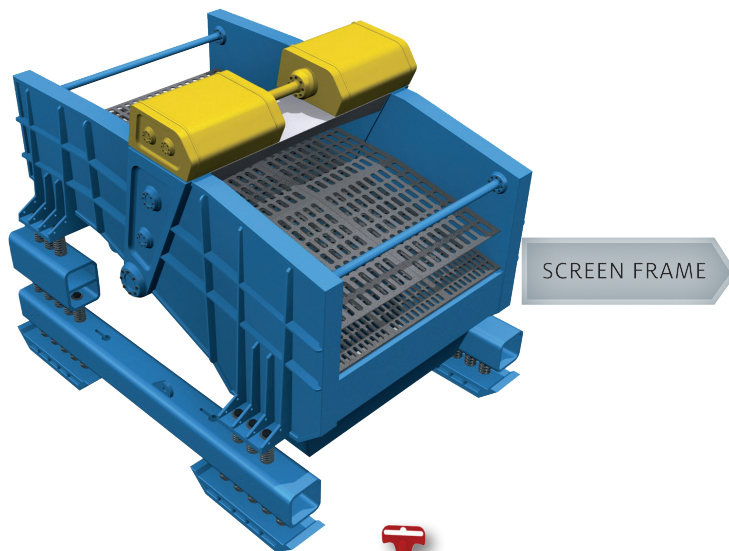
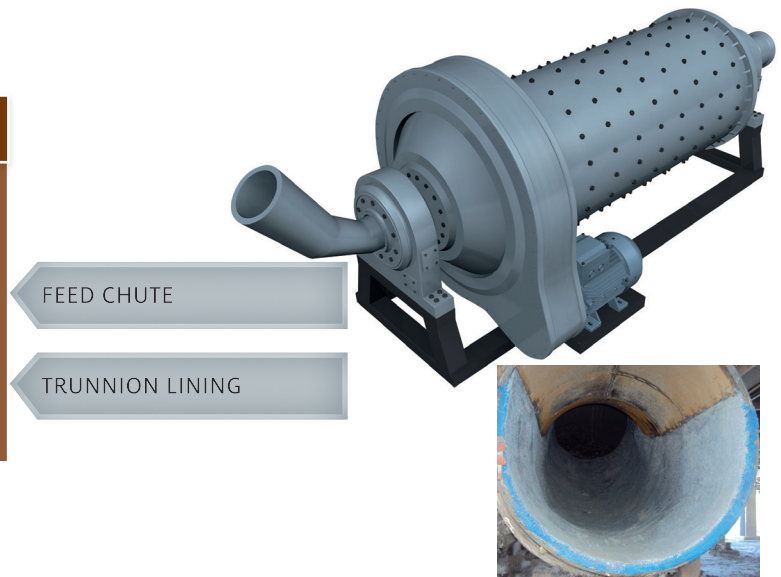

## SCREENS

YOUR CHALLENGE	OUR SOLUTION	BENEFITS
Extend the life of the screen structure against severe abrasion	<b>FRAME PROTECTION:</b> Apply LOCTITE High Impact Wearing Compound/Pneu-Wear Wearing Compound	<ul style="list-style-type: none"> <li>• Increase life of the structure</li> <li>• Reduce risk of major failures</li> </ul>







## SLURRY PUMPS

YOUR CHALLENGE	OUR SOLUTION	BENEFITS
Repair damaged areas on rubber/metal	<b>ABRASION PROTECTION:</b> Apply LOCTITE Fast Cure Wearing Compound/High Impact Wearing Compound	<ul style="list-style-type: none"> <li>• Reduce MTTR</li> <li>• Extend the operation of the pump</li> <li>• Avoid major failures</li> <li>• Cost savings by rebuilding expensive spare parts</li> </ul>

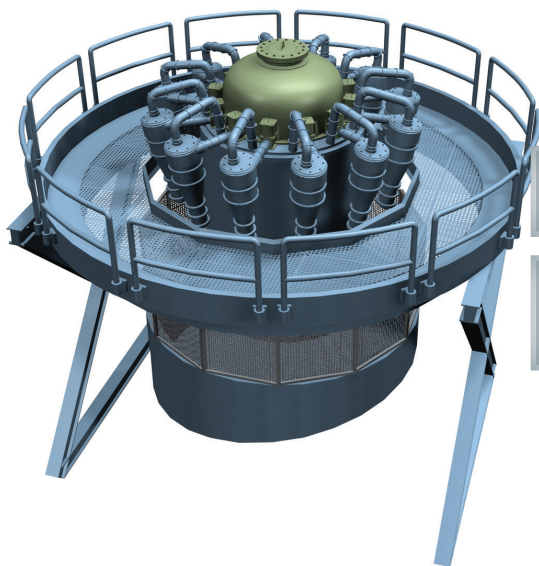

DISCHARGE BIN

APEX AND MANIFOLD LINERS

## HYDROCYCLONES

YOUR CHALLENGE	OUR SOLUTION	BENEFITS
Protect the bottom area of discharge bin against abrasion/impact	<b>WEAR PROTECTION:</b> Apply LOCTITE High Impact Wearing Compound	<ul style="list-style-type: none"> <li>• Increase MTBF</li> <li>• Reduce risk of major failures</li> <li>• Permit repairs during planned shutdowns</li> </ul>



## Information and Resources

Maintenance guides, application videos, catalogs, case studies and more – just a click away.

Visit [henkelna.com/mining](http://henkelna.com/mining)

# Our LOCTITE solutions provide:

Surface protection • Abrasion resistance • Extended equipment life

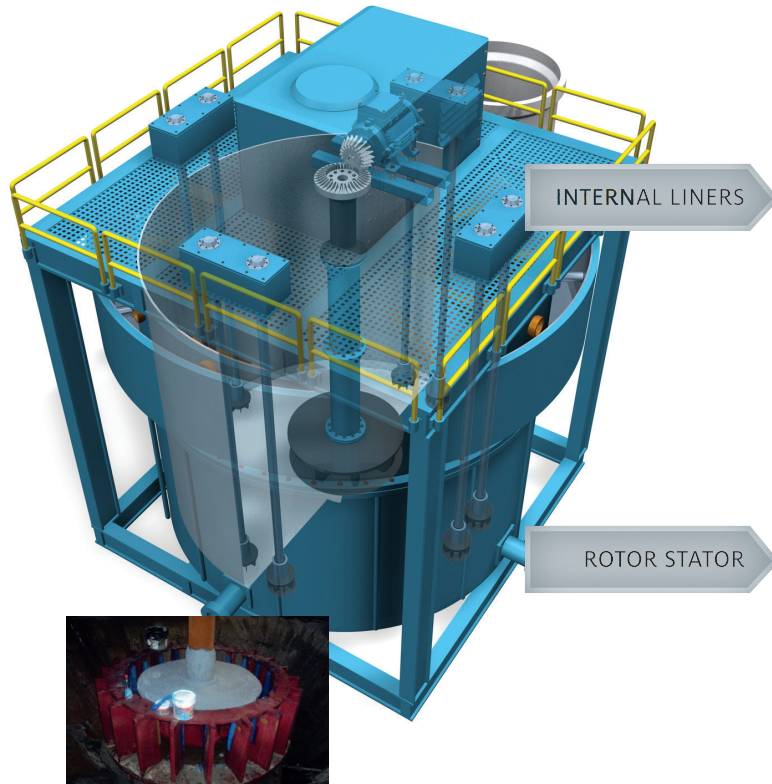

## FLOTATION CELLS

YOUR CHALLENGE	OUR SOLUTION	BENEFITS
Repair damaged areas over rubber liners internally	<b>WEAR/CORROSION PROTECTION:</b> Apply LOCTITE Brushable Ceramic/High Impact Wearing Compound	<ul style="list-style-type: none"> <li>• Reduce MTTR</li> <li>• Reinforce areas suffering more abrasion with a high impact/high wear resistant solution</li> <li>• Permit repairs during planned shutdowns</li> </ul>
Repair damaged rubber	<b>WEAR/CORROSION PROTECTION:</b> Apply LOCTITE Fast Cure Wearing Compound/High Impact Wearing Compound	<ul style="list-style-type: none"> <li>• Reduce MTTR</li> <li>• Reinforce areas suffering more abrasion with a high impact/high wear resistant solution</li> <li>• Permit repairs during planned shutdowns</li> </ul>
Protect main shaft surface against corrosion	<b>WEAR/CORROSION PROTECTION:</b> Apply LOCTITE Chemical Resistant Coating	<ul style="list-style-type: none"> <li>• Extend equipment life</li> <li>• Increase MTBF</li> </ul>







## CONCENTRATOR PLANT

DUCTS/ELBOWS/PIPES

CONCRETE REPAIR AND GROUTING

YOUR CHALLENGE	OUR SOLUTION	BENEFITS
Protect damaged areas over rubber/metal surfaces	<b>ABRASION PROTECTION:</b> Apply LOCTITE Fast Cure Wearing Compound/High Impact Wearing Compound	<ul style="list-style-type: none"> <li>• Reduce MTRR</li> <li>• Extend MTBF</li> <li>• Avoid longer shutdowns</li> </ul>
Concrete in floors and chemical-contaminant areas needs to be repaired constantly due to aggressive chemical attack	<b>CORROSION PROTECTION:</b> Apply LOCTITE High Performance Quartz and Chemical Resistant Coating products	<ul style="list-style-type: none"> <li>• Improved safety</li> <li>• Easy to apply, minimizing disruption to production</li> <li>• Long-term solution</li> </ul>

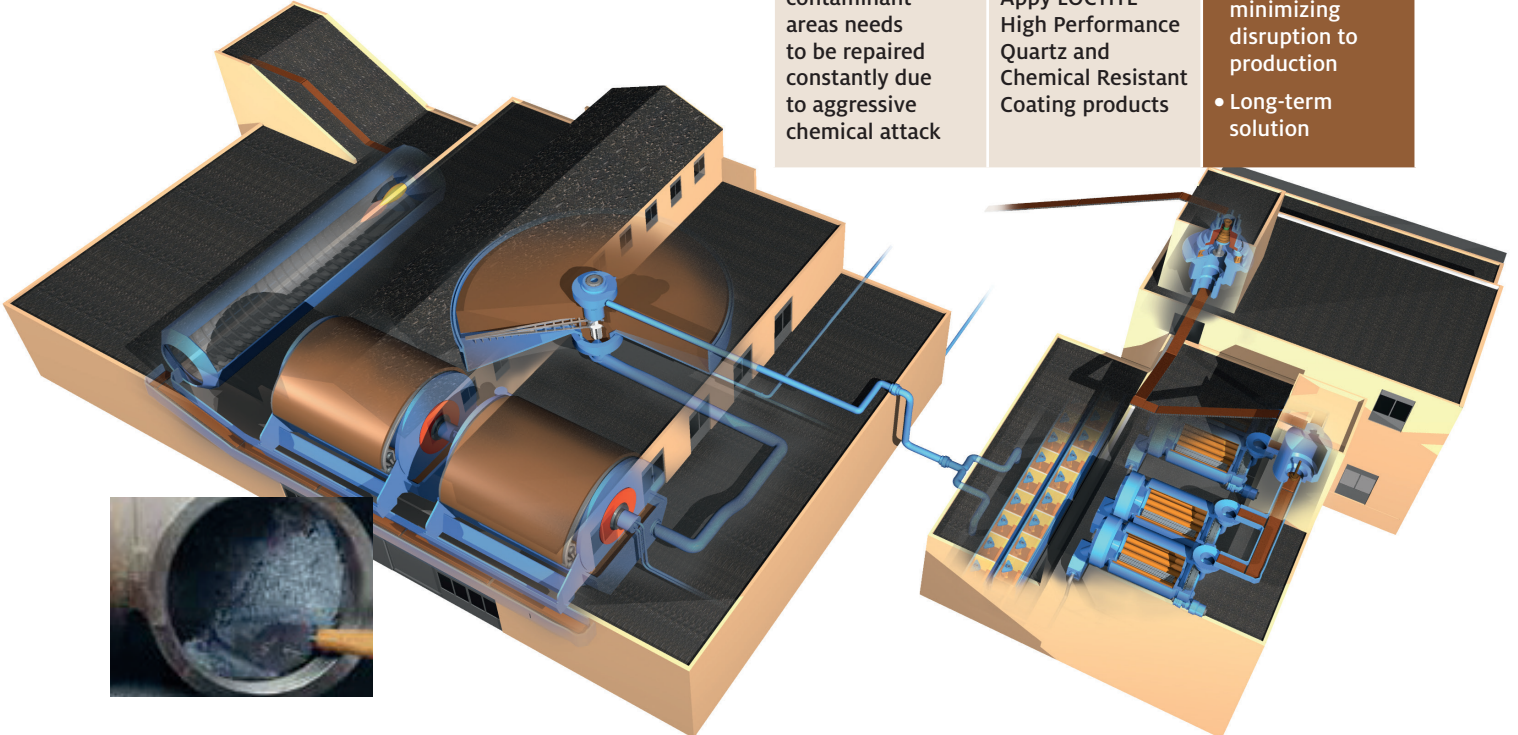

### On-Site Training

Our maintenance workshops will help your staff improve safety and reliability and reduce costs.

Call 1-800-LOCTITE (562.8483) or visit [henkelna.com/training](http://henkelna.com/training)

# Henkel. Understanding your mobile equipment.

## MOBILE EQUIPMENT

YOUR CHALLENGE	OUR SOLUTION	BENEFITS
Maintaining trucks, shovels, loaders and secondary heavy duty equipment under harsh conditions and heavy vibration, resulting in loose fasteners, leaking hydraulic fittings and failing gaskets	LOCTITE Threadlockers, Liquid Gaskets and Hydraulic Sealants	<ul style="list-style-type: none"> <li>• Prevent fastener loosening</li> <li>• Eliminate hydraulic leaks, avoid ISO 14000 issues due to fluid leaks</li> <li>• Increase MTBF, increase reliability of equipment.</li> </ul>

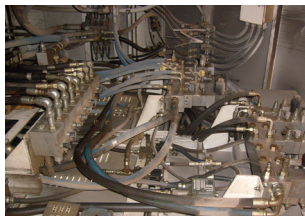



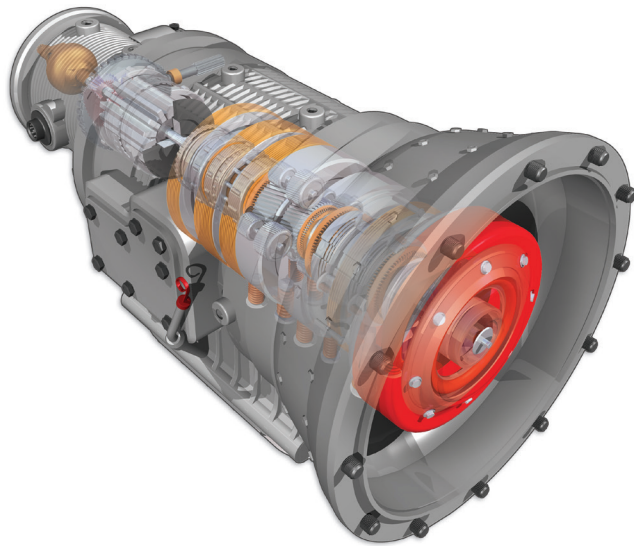
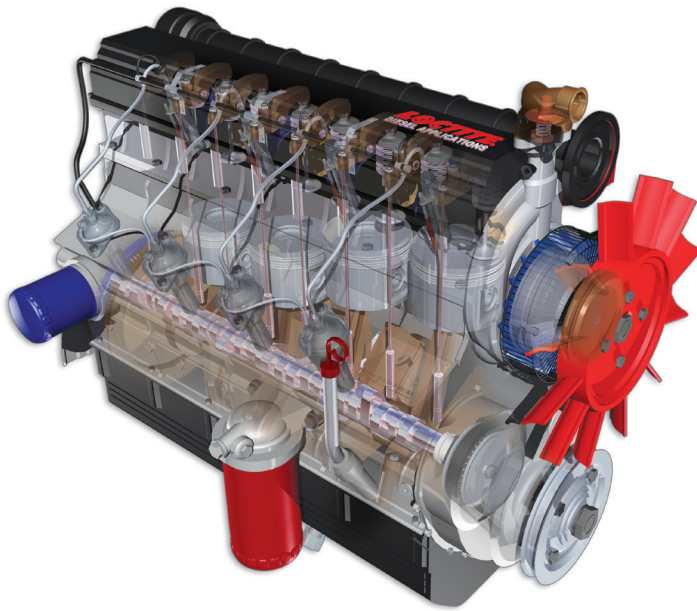

## TRANSMISSION/DIESEL ENGINE

YOUR CHALLENGE	OUR SOLUTION	BENEFITS
Reduce and avoid leaks of hydraulic oil	LOCTITE Gasketing and Thread Sealing	<ul style="list-style-type: none"> <li>• Increase uptime / MTBF, avoid ISO 14000 issues</li> <li>• Increase reliability, increase MTBF</li> </ul>
Prevent parts from loosening due to vibration	LOCTITE Threadlockers	
Prevent spun bearings	LOCTITE Retaining Compounds	
Avoid failures of electrical connectors due to humidity, dust or contaminants	LOCTITE Dielectric Tune-Up Grease	



## Reduce Your Costs

More than 90% of our customers realize above-target cost savings after just 4 months. Let us do the same for you.

Call 1-800-LOCTITE (562.8483) or visit [henkelna.com/mining](http://henkelna.com/mining)



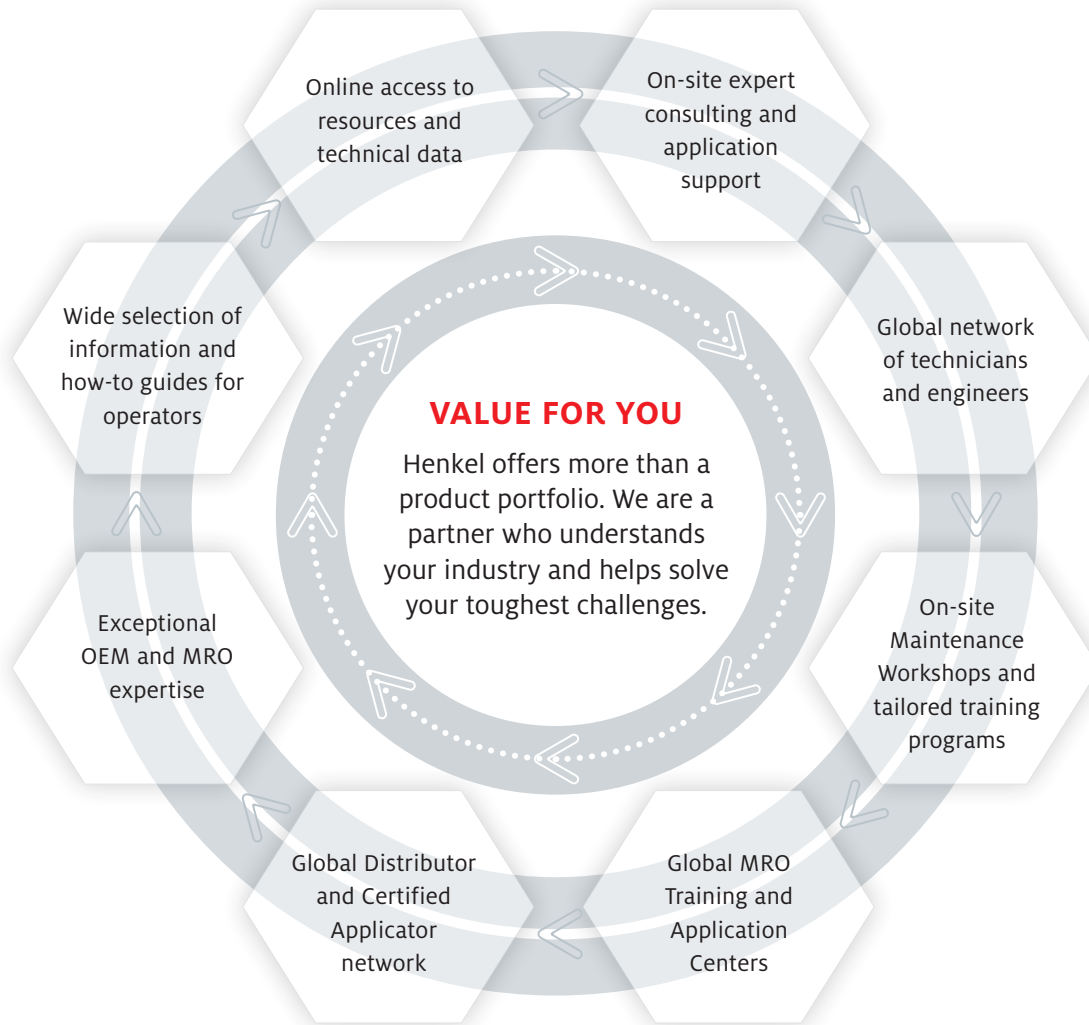

## Broad Solution Portfolio

From reducing wear and corrosion to sealing leaks, Henkel has a wide range of products that can solve any challenge in your facility.



### LOCTITE MACHINERY ADHESIVES

- Threadlocking
- Thread Sealants
- Gasketing
- Retaining



### REBUILDING, PROTECTING AND COATING

- Metal-Filled Compounds
- Concrete Repair
- Wear Resistant Coatings

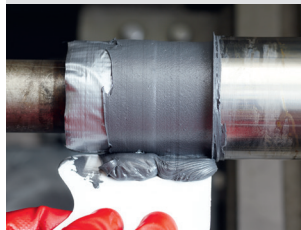

### BONDING AND SEALING WITH LOCTITE

- Epoxies
- Polyurethanes
- Instant Adhesives
- Industrial Sealants



### SUPPLEMENTARY MAINTENANCE PRODUCTS

- Cleaners
- Metal Pretreatment
- Anti-Seize and Lubricants



# Henkel Partnership

Services to help you succeed



## Plant Survey

A plant survey will analyze current maintenance practices and culture and offer opportunities for improvement. It can also be used to customize training workshops specific to your needs.

Date	
Time	
Place	
Contact	



## Product Trials

Product trials allow you to test the performance of our products in your plant. Henkel will train your staff on the correct application methods.

Date	
Time	
Place	
Contact	



## Maintenance Workshop

This on-site training customized to your needs will help your staff increase equipment reliability, reduce routine and redundant maintenance tasks, improve safety, reduce energy costs, and increase productivity.

Date	
Time	
Place	
Contact	



## Surface Engineering Solutions

Our experts will show you how to identify and apply the proper surface protection coatings to keep your assets up and running with minimal downtime. We can also recommend Henkel Certified Applicators who specialize in these types of repairs.

Date	
Time	
Place	
Contact	

For more information, contact your Henkel representative,  
Call 1-800-LOCTITE (562.8483) or visit [henkelna.com/mro](http://henkelna.com/mro)



**U.S.A.**

**Henkel Corporation**  
Engineering Adhesives  
One Henkel Way  
Rocky Hill, Connecticut 06067  
Tel: 1.800.LOCTITE (562.8483)  
Tel: 860.571.5100  
Fax: 860.571.5465

**Canada**

**Henkel Canada Corporation**  
Engineering Adhesives  
2515 Meadowpine Blvd.  
Mississauga, Ontario L5N 6C3  
Tel: 1.800.263.5043 (within Canada)  
Tel: 905.814.6511  
Fax: 905.814.5391

[www.henkelna.com/mining](http://www.henkelna.com/mining)