

LOCTITE®

**ADHESIVE
& SEALANT
SOLUTIONS
THAT STOP
LEAKS BEFORE
THEY START.**



Henkel

LOCTITE® ADHESIVES AND SEALANTS

Solving leak problems. Ensuring peace of mind.

Leaks are a significant and common problem for Manufacturing, Assembly, Installation, and Maintenance professionals. While a certain amount of leakage used to be accepted in the past, leaks are no longer tolerated in today's marketplace. With our technical knowledge, industry experience and innovative sealant and adhesive technologies, we examine the source and help you design new solutions that impact your business.



PROTECTS YOUR BRAND REPUTATION

Better leak prevention and product reliability. Fewer warranty claims.



LOWERS YOUR COSTS

Eliminating costs associated with traditional fastening and sealing technologies.



IMPROVES YOUR COMPETITIVENESS

Separating your product performance from others. Newfound design freedom fosters innovation.

Solutions for today's challenges.



INCREASED RELIABILITY

Thread sealing applications call for higher temperatures, higher pressures and resistance to harsher chemicals. Demands for increased reliability have pushed the boundaries of conventional sealant technology which LOCTITE® sealants have overcome.



LEAK PREVENTION

Pre-cut gaskets have a limited ability to fill in surface irregularities and create a seal. LOCTITE® liquid gasket material can flow into surface irregularities and create a leak-free seal.



PROCESS OPTIMIZATION

Henkel offers various dispensing and curing equipment that can be easily integrated into your manufacturing process to increase efficiency and throughput. Equipment includes manual or pneumatic, portable or stationary, and pressure-time or volumetric dispense systems.

A trusted partner in leak prevention.

LOCTITE® adhesives and sealants are engineered to meet a broad range of fluid processing applications. With our world-class, innovative product technologies and our extensive industry experience, Henkel can help you optimize product performance and reduce overall costs.



SOLUTIONS FOR A WIDE RANGE OF NEEDS

Our range of solutions.

Thread Sealing

SEALING THREADED COMPONENTS

- Seals against aggressive fluids / high pressure
- Prevents corrosion
- Suitable for all thread types
- Can replace or augment seals & o-rings
- Adjustable joints / no re-torquing necessary

BENEFITS

- Improved reliability / extended life expectancy
- Lower service and repair costs
- Fewer parts / lower inventory costs

Retaining

SECURING CYLINDRICAL ASSEMBLIES

- Allows higher load transfer with existing designs
- Prevents fretting corrosion and micromovements
- Replaces mechanical fasteners
- Allows slip fits / replaces or enhances interference fits

BENEFITS

- Reduced costs
- Increases reliability for longer product life
- Cost-efficient designs (fewer components / reduced tolerance)
- Higher mechanical strength

Gasketing

SEALING FLANGES

- 100% metal to metal contact –no leakage
- Fills surface defects
- Helps reach high IP rating
- No gasket relaxation nor displacement
- Can replace compression gaskets and o-rings

BENEFITS

- Lower inventory costs and complexity reduction – eliminate need to store different gasket types
- Increased reliability / product life

Structural & Instant Bonding

JOINING AND SEALING DISSIMILAR MATERIALS

- Fill gaps, allow wider tolerances
- Prevent stress concentration from traditional joining methods

BENEFITS

- Flexibility in substrate design
- Fewer parts, simpler design
- Lower cost, lower weight
- Super fast-curing grades available

Threadlocking

LOCKING THREADED FASTENERS

- Locking against vibration – no bolt loosening
- Fill all voids – prevent relative movement
- Prevents corrosion
- Replaces traditional mechanical locking devices

BENEFITS

- Improvement / preservation of clamp load
- Improved reliability / extended life expectancy
- Lower service and repair costs

Complementary Solutions

To complete the product portfolio across the entire value chain, Henkel offers various other solutions to cover your needs:

LOCTITE® anti-seize products to protect parts against rust, corrosion, seizing and galling, and for lubricating parts.

LOCTITE® potting and encapsulating compounds to fill large voids, and protect components from exposure to chemicals, moisture, shock and vibration.

LOCTITE® cleaners for parts cleaning prior to bonding

BONDERITE® cleaners to clean and protect parts during all phases of your manufacturing process

For a range of fluid processing devices.

CENTRIFUGAL PUMP

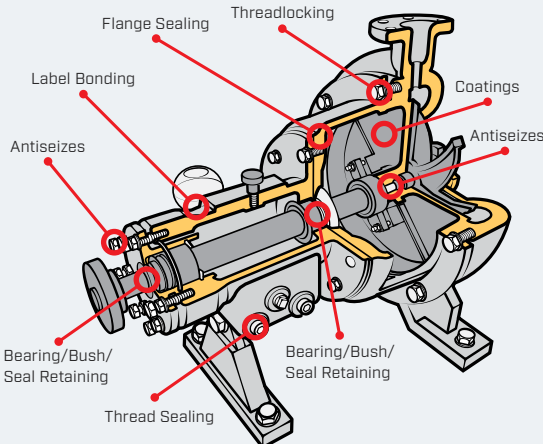

COMPRESSOR

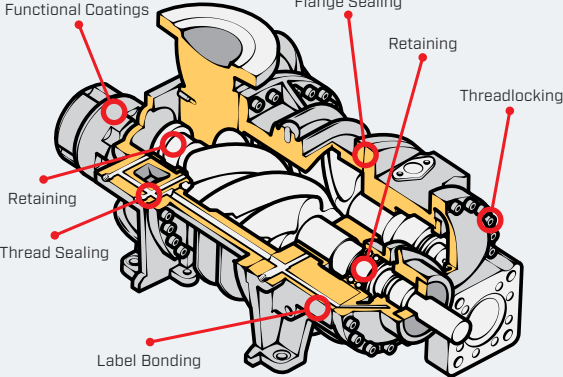

DIAPHRAGM PUMP

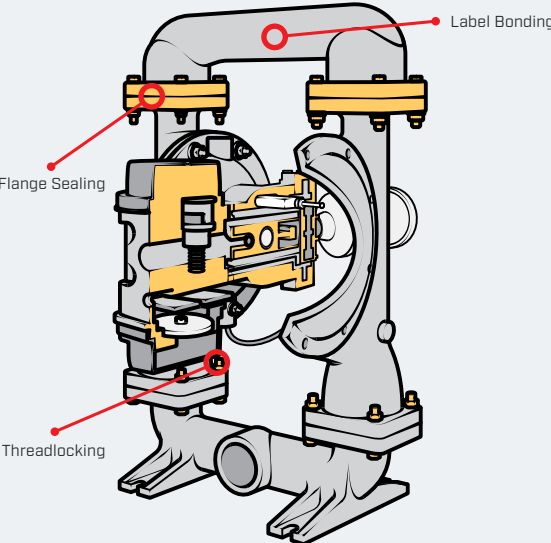

GLOBE VALVE

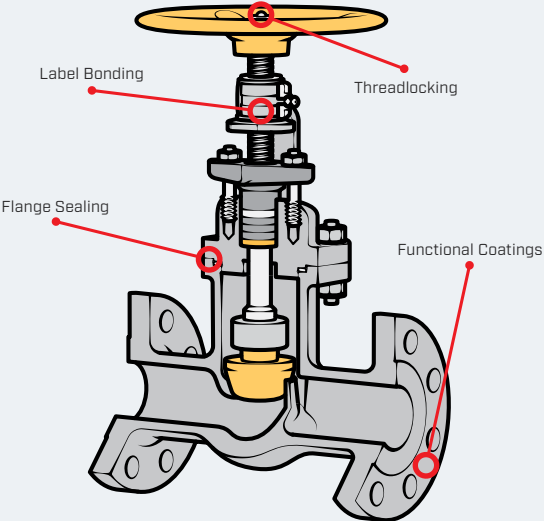

ACTUATOR

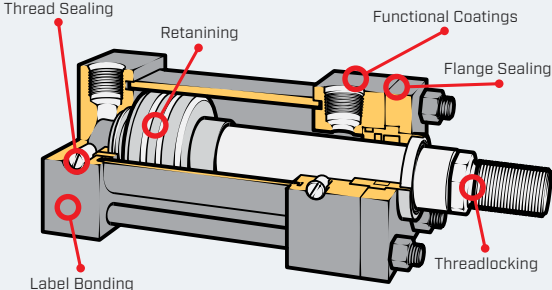

VALVE MANIFOLD

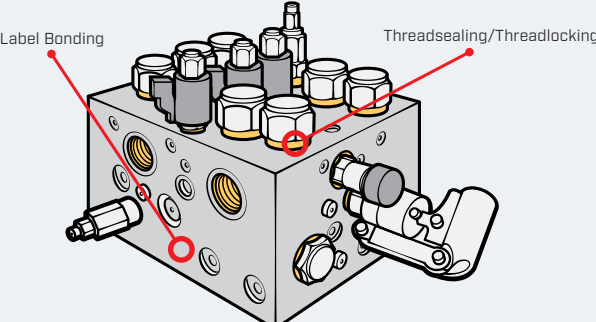

SPECIFIC SOLUTIONS FOR MACHINERY ASSEMBLY

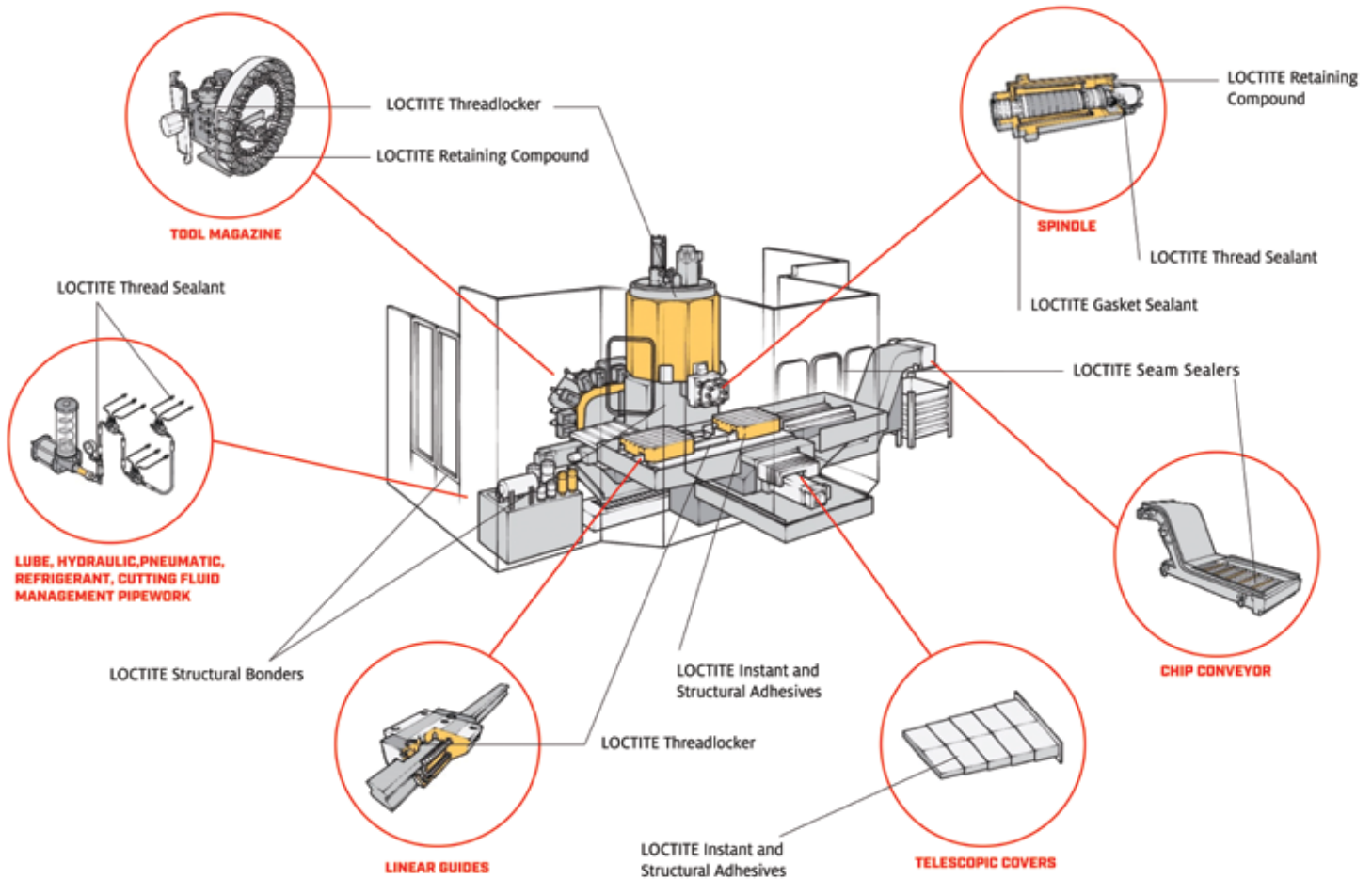

All marks used are trademarks and/or registered trademarks of Henkel and its affiliates in the U.S., Germany and elsewhere. © 2011 Henkel Corporation. All rights reserved. XXXXX (6/14)

Improve your machinery, robots and automated lines.

Incorporating new materials, new designs in guards, doors, windows and structures (e.g. bed and frame) to make them lighter while performing better

Using much faster and more reliable sealing systems for all media and working conditions

Reducing vibration and noise

Improving the accuracy and reliability of the mechanisms (e.g. rollers, shafts, flanged couplings or bolted joints) with sustainable solutions

Using faster and certified installation alternatives

Introducing new faster assembly and maintenance operations (e.g. wear liners, sacrificial wearing coatings, rubber seals)

Facilities professionals in any industry can rely on.

LOCTITE® adhesives, sealants, lubricants and other repair products to increase equipment reliability, reduce downtime, and minimize equipment failures.

LOCTITE® THREAD SEALANT PROPERTIES CHART

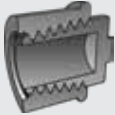
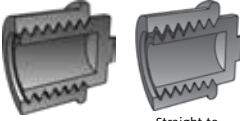
Product	Thread Type	Appearance	Typical Use	Max Thread Size	Breakaway Torque	Instant Low Pressure Seal	Fluorescence	Service Temperature Range	Part No./ Container Size	Agency Approvals
LOCTITE® 567™	 Tapered Thread	Opaque paste	Controlled strength for tapered threads	M80 or 3" NPT	8 Nm*	Yes	No	-55 to 250°C (-65°F to 480°F)	2087067 50 ml 2087069 250 ml	CSA, CFIA, ABS NSF/ANSI 61, UL, ULC
LOCTITE® 577™	 Straight Thread Straight to Tapered Thread	Yellow paste	Medium strength for straight threads	M80 or 3"	15 Nm**	Yes	Yes	-55 to 180°C (-65°F to 355°F)	2068749 50 ml 2068748 250 ml	NSF P1, DVGW

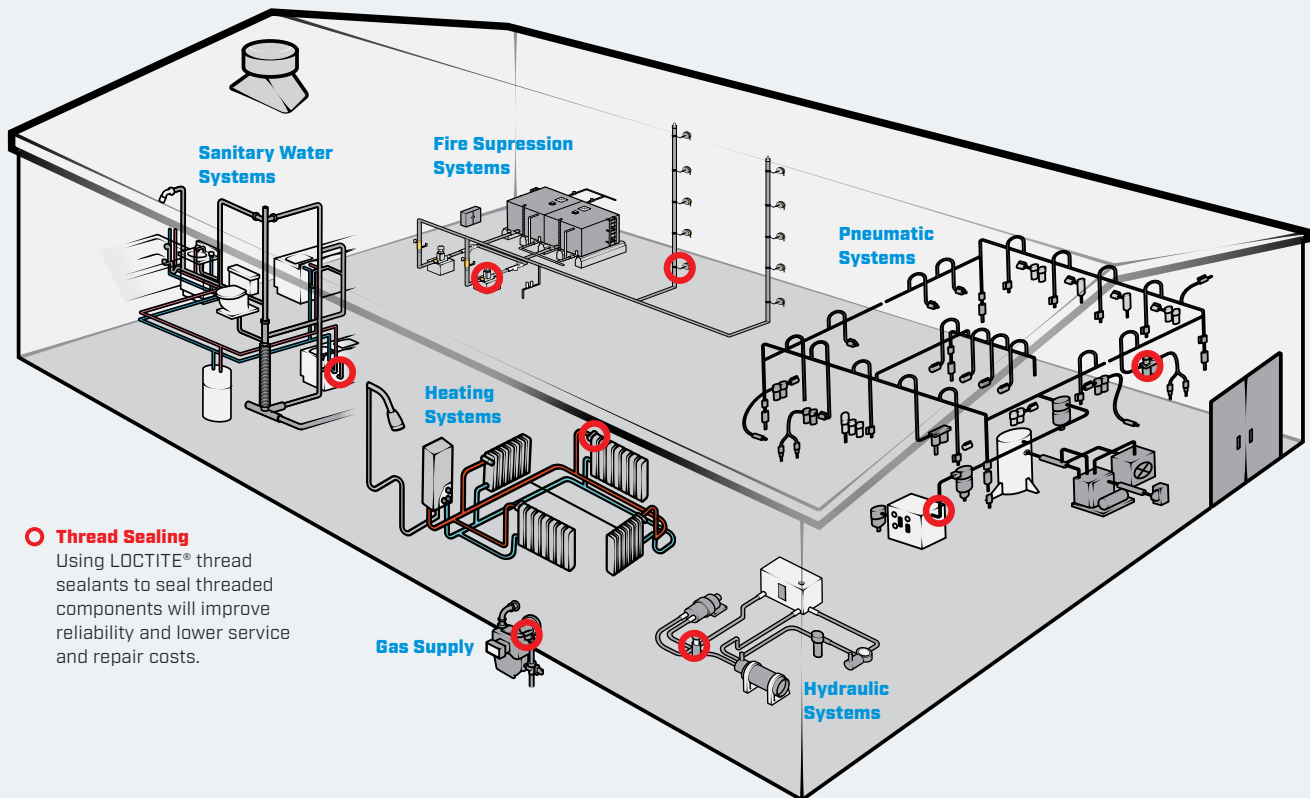



Henkel Corporation
Engineering Adhesives
www.na.henkel-adhesives.com/fluidprocessing
www.loctite.com

U.S.A.
Henkel Corporation
Engineering Adhesives
One Henkel Way
Rocky Hill, Connecticut 06067
Tel: 1.800.LOCTITE (562.8483)
Tel: 860.571.5100
Fax: 860.571.5465

Canada
Henkel Canada Corporation
Engineering Adhesives
2515 Meadowpine Blvd.
Mississauga, Ontario L5N 6C3
Tel: 1.800.263.5043 (within Canada)
Tel: 905.814.6511
Fax: 905.814.5391

The data contained herein are intended as reference only. Please contact Henkel for assistance and recommendation on specifications for these products.

All marks used are trademarks and/or registered trademarks of Henkel and its affiliates in the U.S., Germany and elsewhere.
© 2018 Henkel Corporation. All rights reserved. 1149484/LT-8401 (08/2018)