

Selection Guide

# Thermal Interface Materials

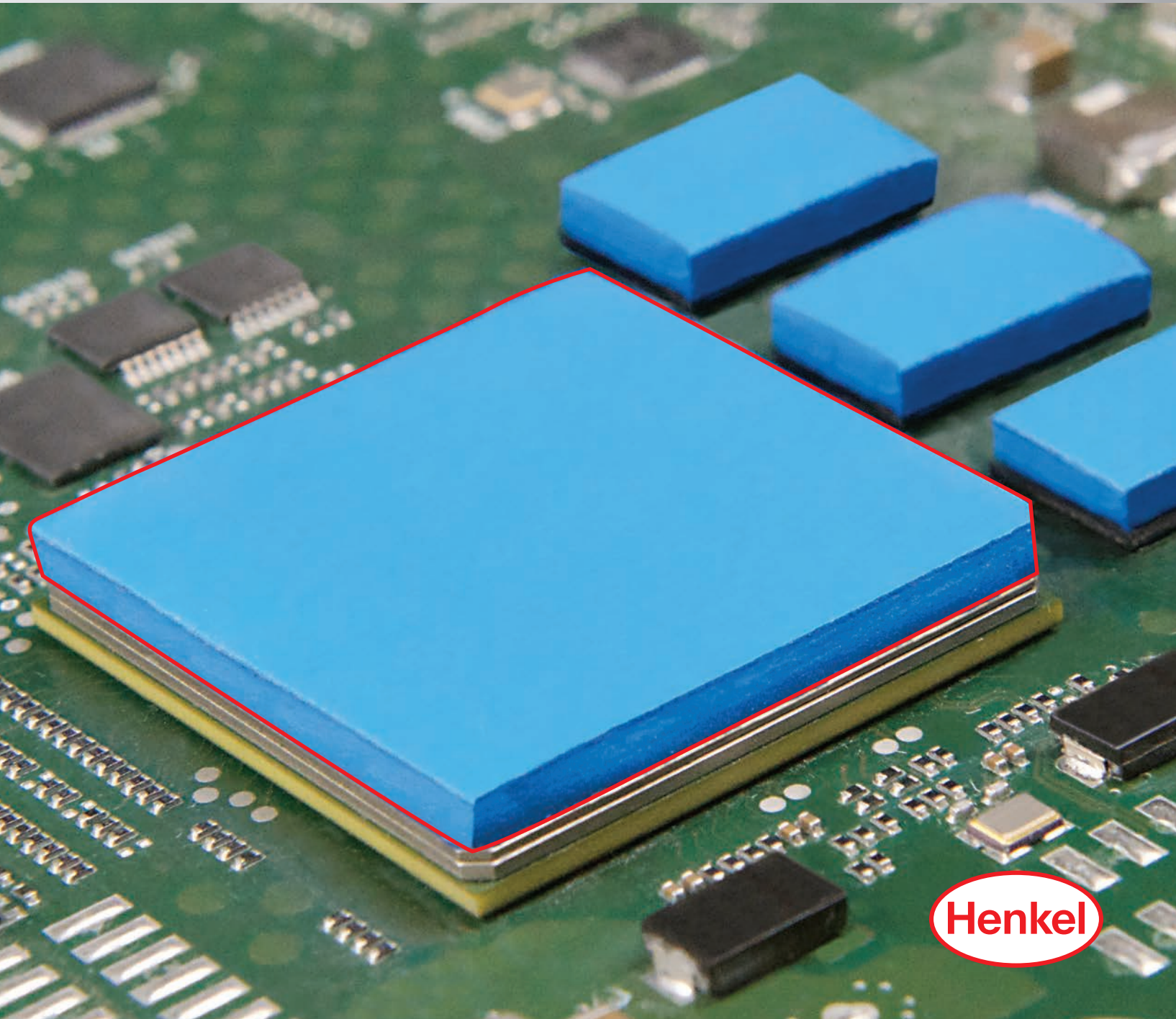

# Table of Contents

<b>Introduction</b> .....	<b>2</b>
Thermal Properties and Testing	4
Interface Material Selection Guide	5
<b>GAP PAD Thermally Conductive Materials</b> .....	<b>6</b>
GAP PAD Comparison Data	7
Frequently Asked Questions	8
GAP PAD VO	9
GAP PAD VO Soft	10
GAP PAD VO Ultra Soft	11
GAP PAD HC 3.0	12
GAP PAD HC 5.0	13
GAP PAD 1000HD	14
GAP PAD 1000SF	15
GAP PAD HC1000	16
GAP PAD 1450	17
GAP PAD 1500	18
GAP PAD 1500R	19
GAP PAD 1500S30	20
GAP PAD A2000	21
GAP PAD 2000S40	22
GAP PAD 2200SF	23
GAP PAD A3000	24
GAP PAD 3500ULM	25
GAP PAD 5000S35	26
GAP PAD EMI 1.0	27
<b>Gap Filler Liquid Dispensed Materials and Comparison Data</b> .....	<b>28</b>
Frequently Asked Questions	29
Gap Filler 1000 (Two-Part)	30
Gap Filler 1000SR (Two-Part)	31
Gap Filler 1100SF (Two-Part)	32
Gap Filler 1400SL (Two-Part)	33
Gap Filler 1500 (Two-Part)	34
Gap Filler 1500LV (Two-Part)	35
Gap Filler 2000 (Two-Part)	36
Gap Filler 3500LV (Two-Part)	37
Gap Filler 3500S35 (Two-Part)	38
Gap Filler 4000 (Two-Part)	39
<b>Thermal Interface Compounds Comparison and FAQs</b> .....	<b>40</b>
TIC 1000A	41
TIC 4000	42
LIQUI-FORM 2000	43
LIQUI-FORM 3500	44
<b>HI-FLOW Phase Change Interface Materials</b> .....	<b>45</b>
HI-FLOW Comparison Data	46
Frequently Asked Questions	47
HI-FLOW 105	48
HI-FLOW 225F-AC	49
HI-FLOW 225UT	50

HI-FLOW 300P	51
HI-FLOW 565UT	52
HI-FLOW 625	53
HI-FLOW 650P	54
<b>Thermally Conductive Insulators</b>	<b>55</b>
Frequently Asked Questions	56
Choosing SIL PAD Thermally Conductive Insulators	57
SIL PAD Comparison Data	58
Mechanical, Electrical and Thermal Properties	59
SIL PAD Thermally Conductive Insulator Selection Table	61
SIL PAD 400	63
SIL PAD 800	64
SIL PAD 900S	65
SIL PAD 980	66
SIL PAD 1100ST	67
SIL PAD 1200	68
SIL PAD A1500	69
SIL PAD 1500ST	70
SIL PAD 2000	71
SIL PAD A2000	72
SIL PAD K-4	73
SIL PAD K-6	74
SIL PAD K-10	75
Q-PAD II	76
Q-PAD 3	77
POLY-PAD 400	78
POLY-PAD 1000	79
POLY-PAD K-4	80
POLY-PAD K-10	81
SIL PAD Tubes	82
<b>BOND-PLY and LIQUI-BOND Adhesives</b>	<b>83</b>
BOND-PLY and LIQUI-BOND Comparison Data and FAQs	84
BOND-PLY 100	85
BOND-PLY 400	86
BOND-PLY 660P	87
BOND-PLY 800	88
BOND-PLY LMS-HD	89
LIQUI-BOND EA 1805 (Two-Part)	90
LIQUI-BOND SA 1000 (One-Part)	91
LIQUI-BOND SA 1800 (One-Part)	92
LIQUI-BOND SA 2000 (One-Part)	93
LIQUI-BOND SA 3505 (Two-Part)	94
<b>Ordering</b>	<b>95</b>
SIL PAD Configurations	95
HI-FLOW Configurations	101
<b>Solutions for Surface Mount Applications</b>	<b>102</b>
<b>Where Thermal Solutions Come Together</b>	<b>103</b>
<b>Ordering Information</b>	<b>104</b>



# Henkel. Developing solutions for the electronics industry.

Proven thermal management solutions and problem-solving partnership.

We make it our business to know your business. We understand your problems. We also know that there will always be a better way to help you reach your goals and objectives. To that end, our company continually invests considerable time and money into research and development.

[Henkel is in the business of solving problems.](#) With our history and experience in the electronics industry, our experts can help find ways to improve your process, control and manage heat, and back it all with exceptional service.

[Let us show you the value Henkel offers.](#)





### THERMAL MANAGEMENT LEADER

Our solutions to control and manage heat in electronic assemblies and printed circuit boards are used by many of the world's largest OEMs in a wide range of industries



### GLOBAL SUPPORT

with locations in North America, Asia and Europe, and sales staff in 30 countries



### INNOVATION

Henkel's BERGQUIST thermal solutions were often developed for specific customer requests

## WHY Henkel?

Henkel, the leading solution provider for adhesives, sealants and functional coatings worldwide, uses high-quality BERGQUIST thermal management products—like BERGQUIST TCLAD, BERGQUIST SIL PAD and BERGQUIST LIQUI-BOND—to offer technological solutions for electronics. Beyond that, we work closely with our customers to understand your problems and deliver technologically advanced solutions backed by exceptional service.



### GLOBAL SUPPLY CHAIN

to maintain a reliable supply of products to our customers



### BROAD PRODUCT PORTFOLIO

that includes LOCTITE, TECHNOMELT and BERGQUIST products

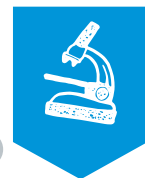

### R&D

Over 10 R&D Centers around the world staffed by 3,000 design and application professionals

# Thermal Properties and Testing

## Thermal Conductivity

The time rate of heat flow through a unit area producing a unit temperature difference across a unit thickness.

$$k = \frac{dq \cdot z}{dt \cdot A \cdot \Delta T}$$

Thermal conductivity is an inherent or absolute property of the material.

## Thermal Impedance

A property of a particular assembly measured by the ratio of the temperature difference between two surfaces to the steady-state heat flow through them.

$$Z_{\theta} = \frac{z}{k \cdot A} + R_i$$

Factors affecting thermal impedance include:

**Area:** Increasing the area of thermal contact decreases thermal impedance.

**Thickness:** Increasing the insulator thickness increases thermal impedance.

**Pressure:** Increasing mounting pressure under ideal conditions decreases thermal impedance.

**Time:** Thermal impedance decreases over time.

**Measurement:** Thermal impedance is affected by the method of temperature measurement.

Thermal Impedance Per BERGQUIST TO-220 Thermal Performance (25°C Cold Plate Testing)

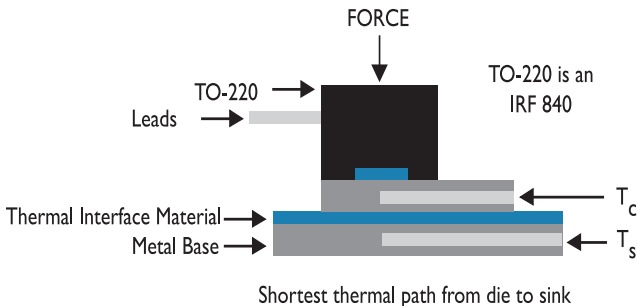

$$Z_{\theta} = \frac{\Delta T}{P_D}$$

## Thermal Resistance

The opposition to the flow of heat through a unit area of material across an undefined thickness.

$$R_{\theta} = \frac{z}{k}$$

Thermal resistance varies with thickness.

## Test Methods – ASTM D5470

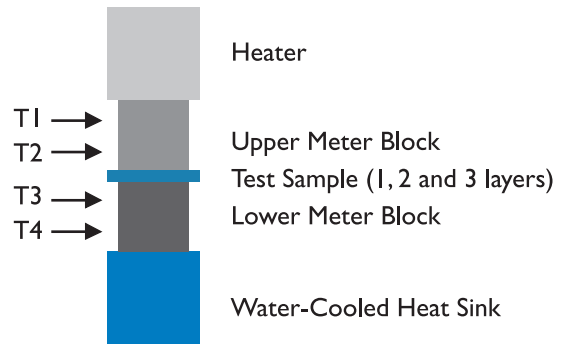

2 in. diameter stack (ref. 3.14 in.<sup>2</sup>) – 10-500 psi, 1 hour per layer

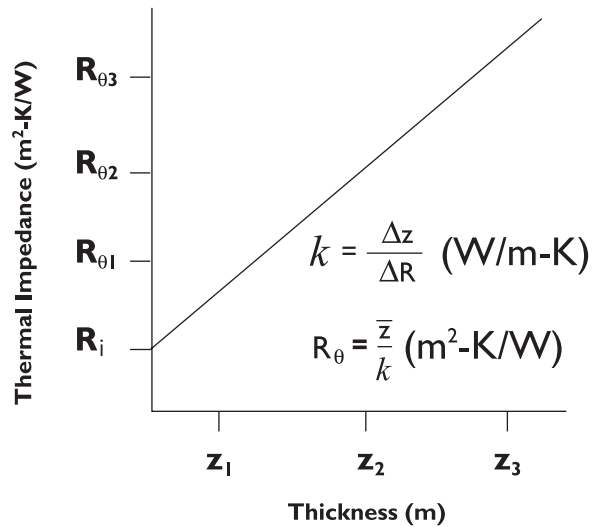



# Interface Material Selection Guide

PRODUCT OVERVIEW		INTERFACE APPLICATIONS						MOUNTING METHODS			TYPICAL CONVERTED OPTIONS					
MARKET APPLICATIONS	PRODUCTS	DISCRETE POWER DEVICES FOR POWER SUPPLIES, COMPUTERS, TELECOM (THRU-HOLE)	ACTIVE POWER COMPONENTS: CAPACITORS, INDUCTORS, RESISTORS	ELECTRONIC MODULES FOR AUTOMOTIVE: MOTOR AND WIPER CONTROLS, ANTI-LOCK, ETC.	ELECTRONIC MODULES FOR TELECOM AND POWER SUPPLIES	COMPUTER APPLICATIONS: CPU, GPU, ASICs, HARD DRIVES (I)	ELECTRICAL INSULATOR	CLIP, LOW PRESSURE	SCREW/RIVETS, HIGH PRESSURE	NOT APPLICABLE	SHEET STOCK	ROLL FORM, CONTINUOUS	STANDARD CONFIGURATIONS	CUSTOM EXTERNAL SHAPES	CUSTOM INTERNAL FEATURES	STANDARD PSA OFFERINGS
Grease Replacement Materials	Q-PAD II	T		T	T	T		T	T		A	A	A	A	A	A
	Q-PAD 3	T		T	T	T		T	T		A	A	A	A	A	A
	HI-FLOW 105	T			AS	AS		T			A	A	A	A	A	A
	HI-FLOW 300G	T			T	T		T	AS		A	A	A	A	A	A
	HI-FLOW 225F-AC	T			T			T			A	A	A	AS		
	HI-FLOW 225UT					T		T			AS	A	A	AS		
HI-FLOW 565UT					T	T	T			AS	A	A	AS			
Grease Replacement Materials - Insulated	HI-FLOW 625	T					T	T			A	A	A	A	A	A
	HI-FLOW 300P	T					T	T			A	A	A	A	A	A
	HI-FLOW 650P	T					T	T			A	A	A	A	A	A
Bonding - Thin Film	BOND-PLY 660P	T			T	T	T		T	A	A	A	A	A	A	
Bonding - Fiberglass	BOND-PLY 100	T			T	T	T		T	A	A	A	A	A	A	
	BOND-PLY 800	T			T	T	T		T	A	A	A	A	A	A	
Bonding - Unreinforced Bonding - Laminates	BOND-PLY 400	T			T	T	T		T	A	A	A	A	A	A	
	BOND-PLY LMS-HD	T		T	AS		T		T	A	A	A	A	A	A	
SIL PAD - Fiberglass	SIL PAD 400	T		T	T	T	T	T		A	A	A	A	A	A	
	SIL PAD 800	T		T	T	T	T	T		A	A	A	A	A	A	
	SIL PAD 900S	T		T	T	T	T	T		A	A	A	A	A	A	
	SIL PAD 980	T		T	T	T	T	T		A	A	A	A	A	A	
	SIL PAD 1100ST	T		T	T	T	T	T		A	A	A	A	A	A	
	SIL PAD 1200	T		T	T	T	T	T		A	A	A	A	A	A	
	SIL PAD A1500	T		T	T	T	T	T		A	A	A	A	A	A	
	SIL PAD 1500ST	T		T	T	T	T	T		A	A	A	A	A	A	
	SIL PAD 2000	T		T	T	T	T	AS		A	A	A	A	A	A	
	SIL PAD A2000	T		T	T	T	T	AS	T	A	A	A	A	A	A	
SIL PAD - Thin Film Polyimide	SIL PAD K-4	T		T	T	T	T	T		A	A	A	A	A	A	
	SIL PAD K-6	T		T	T	T	T	T		A	A	A	A	A	A	
	SIL PAD K-10	T		T	T	T	T	T		A	A	A	A	A	A	
GAP PAD	GAP PAD VO	T	T	T	T	T	T	T		A	A*	A	A	AS	A	
	GAP PAD VO Soft	T	T	T	T	T	T	T		A	A*	A	A	AS	A	
	GAP PAD VO Ultra Soft	T	T	T	T	T	T	T		A	A*	A	A	AS	A	
	GAP PAD HC 3.0	T	T	T	T	T	T	T		A	A*	A	A	AS	A	
	GAP PAD HC 5.0	T	T	T	T	T	T	T		A	A*	A	A	AS	A	
	GAP PAD 1000HD	T	T	T	T	T	T	T		A	A*	A	A	AS	A	
	GAP PAD 1000SF	T	T	T	T	T	T	T		A	A	A	A	AS		
	GAP PAD HC 1000	T	T			T	T	T		A	A*	A	A	A		
	GAP PAD 1450	T	T			T	T	T		A	A*	A	A	A		
	GAP PAD 1500	T	T			T	T	T		A	A*	A	A	AS		
	GAP PAD 1500R	T	T	T		T	T	T		A	A*	A	A	A		
	GAP PAD 1500S30	T	T	T	T	AS	T	T		A		A	A	A		
	GAP PAD A2000	T	T			AS	T	T		A	A*	A	A	A		
	GAP PAD 2000S40	T	T			AS	T	T		A		A	A	A		
	GAP PAD 2200SF	T	T	T	T	T	T	T		A		A	A	AS		
	GAP PAD A3000	T	T	T	T	AS	T	T		A	A*	A	A	A		
	GAP PAD 3500ULM	T	T	T	T	AS	T	T		A	A*	A	A	A		
	GAP PAD 5000S35	T	T	T	T	AS	T	T				A	A	A		
Gap Filler	Gap Filler 1000		T	T	T		AS	T					NA			
	Gap Filler 1000SR		T	T	T		AS	T					NA			
	Gap Filler 1100SF		T	T	T	T	AS	T					NA			
	Gap Filler 1400SL	AS		T	AS								NA			
	Gap Filler 1500		T	T	T		AS	T					NA			
	Gap Filler 1500LV		T	T	T		AS	T					NA			
	Gap Filler 2000		T	T	T		AS	T					NA			
	Gap Filler 3500LV		T	T	T		AS	T					NA			
	Gap Filler 3500S35		T	T	T		AS	T					NA			
Gap Filler 4000		T	T	T		AS	T					NA				
Liquid Adhesive	LIQUI-BOND EA 1805	T		T			AS		T				NA			
	LIQUI-BOND SA 1000	T		T			AS		T				NA			
	LIQUI-BOND SA 1800	T		T			AS		T				NA			
	LIQUI-BOND SA 2000	T		T			AS		T				NA			
	LIQUI-BOND SA 3505	T		T			AS		T				NA			

T = Typical; AS = Application-Specific (contact Henkel Sales); A = Available; \* = Roll stock configurations are limited — contact your Henkel Sales Representative for more information. Note: For HI-FLOW 225UT, 225F-AC and HI-FLOW 565UT, the adhesive is not a pressure sensitive adhesive (PSA).

# GAP PAD Thermally Conductive Materials

## Solution-Driven Thermal Management Products for Electronic Devices

### A Complete Range of Choices for Filling Air Gaps and Enhancing Thermal Conductivity

The BERGQUIST brand is a world leader in thermal interface materials. The GAP PAD family of products was developed to meet the electronic industry's growing need for interface materials with greater conformability, higher thermal performance and easier application.

The extensive GAP PAD family provides an effective thermal interface between heat sinks and electronic devices where uneven surface topography, air gaps and rough surface textures are present. Henkel application specialists work closely with customers to specify the proper GAP PAD material for each unique thermal management requirement.

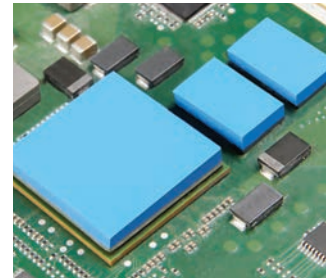
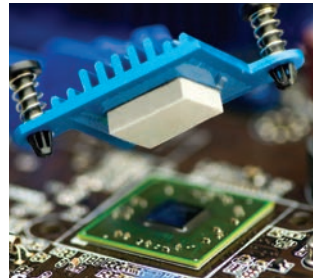

### Features

Each of the many products within the GAP PAD family is unique in its construction, properties and performance. Following is an overview of the important features offered by the GAP PAD family.

- Low-modulus polymer material
- Available with fiberglass/rubber carriers or in a non-reinforced version
- Special fillers to achieve specific thermal and conformability characteristics
- Highly conformable to uneven and rough surfaces
- Electrically isolating
- Natural tack on one or both sides with protective liner
- Variety of thicknesses and hardnesses
- Range of thermal conductivities
- Available in sheets and die-cut parts

### Benefits

GAP PAD thermal products are designed to improve an assembly's thermal performance and reliability while saving time and money.

- Eliminate air gaps to reduce thermal resistance
- High conformability reduces interfacial resistance
- Low-stress vibration dampening
- Shock absorbing
- Easy material handling
- Simplified application
- Puncture, shear and tear resistance
- Improved performance for high-heat assemblies
- Compatible with automated dispensing equipment

### Options

Some GAP PAD products have special features for particular applications, including:

- Available with or without adhesive
- Rubber-coated fiberglass reinforcement
- Thicknesses from 0.010 in. to 0.250 in.
- Available in custom die-cut parts, sheets and rolls (converted or unconverted)
- Custom thicknesses and constructions
- Adhesive or natural inherent tack
- Silicone-free GAP PAD available in thicknesses of 0.010 in. - 0.125 in.

We produce thousands of specials. Tooling charges vary depending on tolerance and complexity of the part.

### Applications

GAP PAD products are well-suited to a wide variety of electronics, automotive, medical, aerospace and military applications such as:

- Between an IC and a heat sink or chassis. Typical packages include BGAs, QFP, SMT power components and magnetics
- Between a semiconductor and heat sink
- CD-ROM/DVD cooling
- Heat pipe assemblies
- Memory modules
- DDR SDRAM
- Hard drive cooling
- Power supply
- IGBT modules
- Signal amplifiers
- Between other heat-generating devices and chassis



# GAP PAD Comparison Data

## Conductivity, Hardness and General Overview

### GAP PAD Thermal Interface Materials

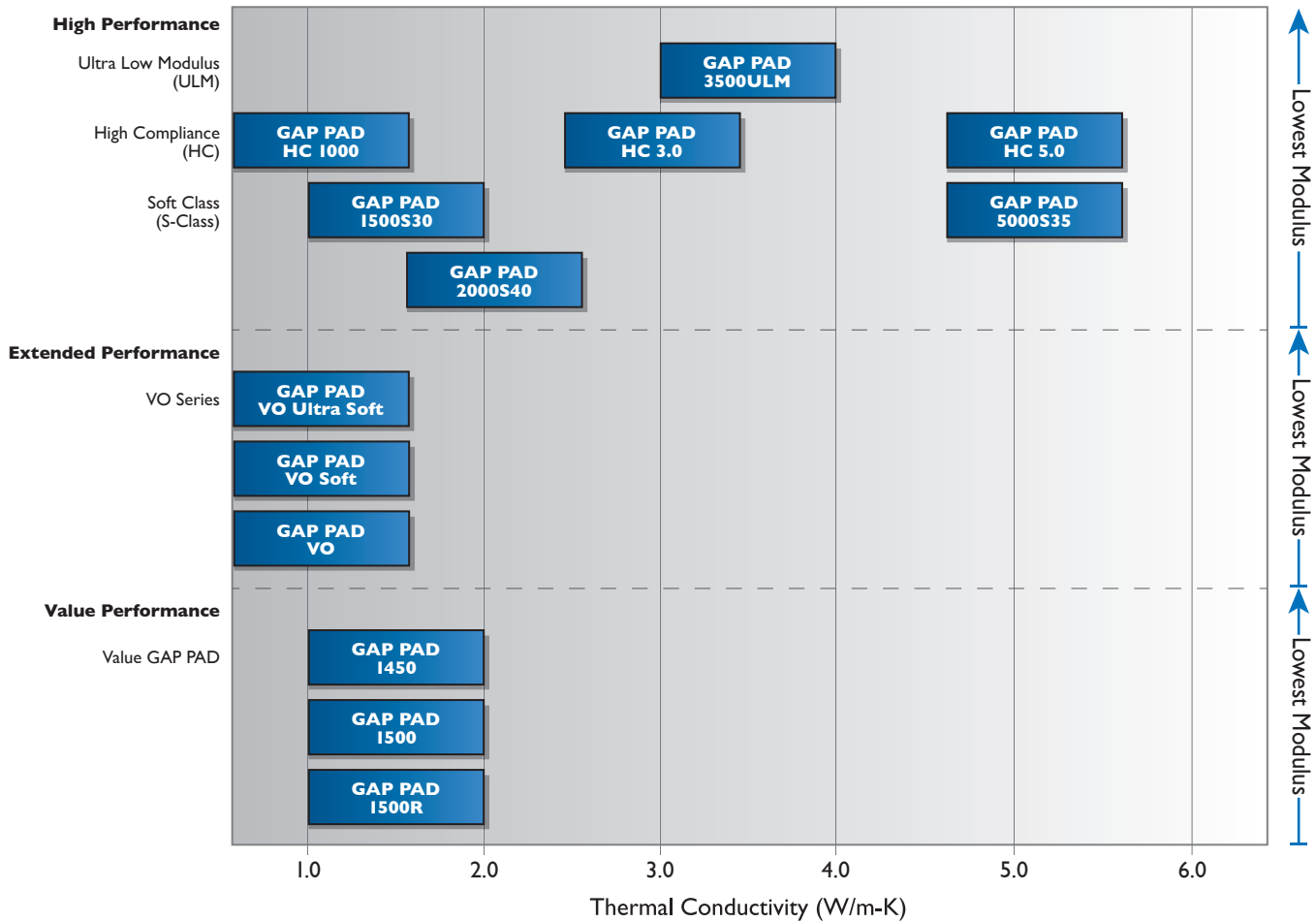

### Specialty GAP PAD Thermal Interface Materials

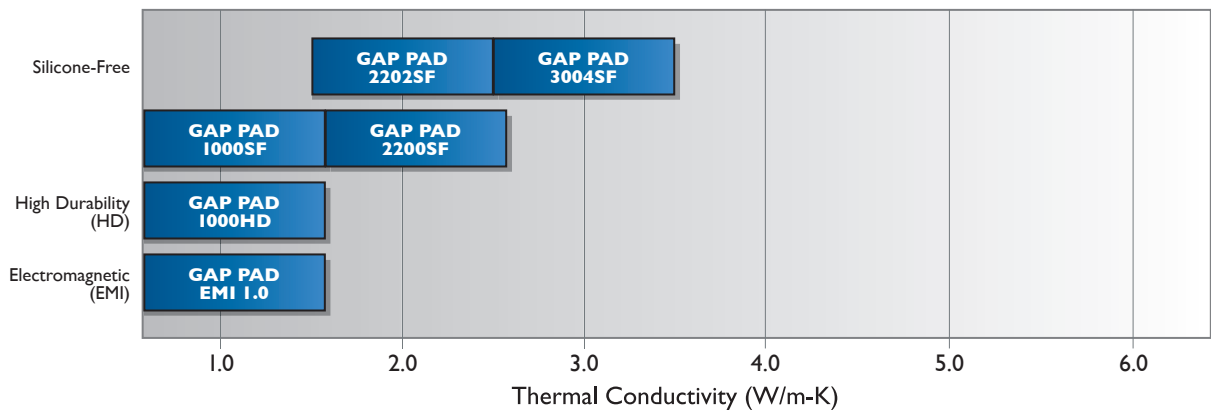

## Frequently Asked Questions

**Q: What thermal conductivity test method was used to achieve the values given on the data sheets?**

**A:** A test fixture is utilized that meets the specifications outlined in ASTM D5470.

**Q: Is GAP PAD offered with an adhesive?**

**A:** Currently, GAP PAD VO, GAP PAD VO Soft, and GAP PAD VO Ultra Soft are offered with or without an adhesive on the SIL PAD 800/900 carrier-side of the material. The remaining surface has natural inherent tack. All other GAP PAD Materials have inherent tack.

**Q: Is the adhesive repositionable?**

**A:** Depending on the surface being applied to, if care is taken, the pad may be repositioned. Special care should be taken when removing the pad from aluminum or anodized surfaces to avoid tearing or delamination.

**Q: What is meant by “natural tack”?**

**A:** The characteristic of the rubber itself has a natural inherent tack, with the addition of an adhesive. As with adhesive-backed products, the surfaces with natural tack may help in the assembly process to temporarily hold the pad in place while the application is being assembled. Unlike adhesive-backed products, inherent tack does not have a thermal penalty since the rubber itself has the tack. Tack strength varies from one GAP PAD product to the next.

**Q: Can GAP PAD with natural tack be repositioned?**

**A:** Depending on the material that the pad is applied to, in most cases they are repositionable. Care should be taken when removing the pad from aluminum or anodized surfaces to avoid tearing or delaminating the pad. The side with the natural tack is always easier to reposition than an adhesive side.

**Q: Is GAP PAD reworkable?**

**A:** Depending on the application and the pad being used, GAP PAD has been reworked in the past. Some of our customers are currently using the same pad for reassembling their applications after burn-in processes and after fieldwork repairs. However, this is left up to the design engineer’s judgment as to whether or not the GAP PAD will withstand reuse.

**Q: Will heat make the material softer?**

**A:** From -60°C to 200°C, there is no significant variance in hardness for silicone GAP PAD Materials and Gap Fillers.

**Q: What is the shelf life of GAP PAD?**

**A:** Shelf life for most GAP PAD Materials is one (1) year after the date of manufacture. For GAP PAD with adhesive, the shelf life is six (6) months from the date of manufacture. After these dates, inherent tack and adhesive properties should be recharacterized. The GAP PAD material’s long-term stability is not the limiter on the shelf life; it is related to the adhesion or “age up” of the GAP PAD to the liner. Or in the case of a GAP PAD with adhesive, the shelf life is determined by how the adhesive ages up to the removable liner.

**Q: How is extraction testing performed?**

**A:** The test method used is the Soxhlet Extraction Method; please refer to GAP PAD S-Class White Paper.

**Q: What is the thickness tolerance of your pads?**

**A:** The thickness tolerance is  $\pm 10\%$  on materials >10 mil and  $\pm 1$  mil on materials  $\leq 10$  mil.

**Q: What are the upper processing temperature limits for GAP PAD and for how long can GAP PAD be exposed to them?**

**A:** GAP PAD in general can be exposed to temporary processing temperatures of 250°C for five minutes and 300°C for one minute.

**Q: Is GAP PAD electrically isolating?**

**A:** Yes, all GAP PAD materials are electrically isolating. However, keep in mind that GAP PAD is designed to fill gaps and it is not recommended for applications where high mounting pressure is exerted on the GAP PAD.

**Q: How much force will the pad place on my device?**

**A:** Refer to the Pressure vs. Deflection charts in BERGQUIST Application Note #116 at our website’s Technical Library. In addition, there are other helpful resources online at [www.henkel-adhesives.com/thermal](http://www.henkel-adhesives.com/thermal).

**Q: Why are “wet out,” “compliance” or “conformability” characteristics of GAP PAD important?**

**A:** The better a GAP PAD lays smooth “wets out” or conforms to a rough or stepped surface, giving less interfacial resistance caused by air voids and air gaps. GAP PAD Materials are conformable or compliant as they adhere very well to the surface. The GAP PAD Materials can act similarly to a “suction cup” on the surface. This leads to a lower overall thermal resistance of the pad between the two interfaces.

**Q: Is anything given off by the material (e.g., extractables, outgassing)?**

- A:**
- 1) Silicone GAP PAD and Gap Fillers, like all soft silicone materials, can extract low molecular weight silicone (refer to White Paper on GAP PAD S-Class). Also note that GAP PAD and Gap Filler have some of the lowest extraction values for silicone-based gap filling products on the market and if your application requires minimal silicone, see our line of silicone-free material. The White Paper on GAP PAD S-Class and information about our silicone-free materials are available on our website.
  - 2) Primarily for aerospace applications, outgassing data is tested per ASTM E595.

**Q: Why does the Technical Data Sheet (on the website) describe the Shore hardness rating as a bulk rubber hardness?**

**A:** A reinforcement carrier is generally used in BERGQUIST GAP PAD Materials for ease of handling. When testing hardness, the reinforcement carrier can alter the test results and incorrectly depict thinner materials as being harder. To eliminate this error, a 250 mil rubber puck is molded with no reinforcement carrier. The puck is then tested for hardness. The Shore hardness is recorded after a 30-second delay.

# GAP PAD VO

## Conformable, Thermally Conductive Material for Filling Air Gaps

### Features and Benefits

- Thermal conductivity: 0.8 W/m-K
- Enhanced puncture, shear and tear resistance
- Conformable gap filling material
- Electrically isolating



GAP PAD VO is a cost-effective, thermally conductive interface material. The material is a filled, thermally conductive polymer supplied on a rubber-coated fiberglass carrier allowing for easy material handling. The conformable nature of GAP PAD VO allows the pad to fill in air gaps between PC boards and heat sinks or a metal chassis.

Note: Resultant thickness is defined as the final gap thickness of the application.

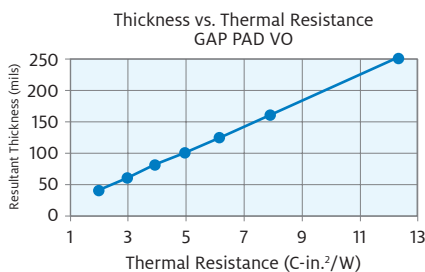

TYPICAL PROPERTIES OF GAP PAD VO			
PROPERTY	IMPERIAL VALUE	METRIC VALUE	TEST METHOD
Color	Gold/Pink	Gold/Pink	Visual
Reinforcement Carrier	SIL PAD	SIL PAD	—
Thickness (in.) / (mm)	0.020 to 0.250	0.508 to 6.350	ASTM D374
Inherent Surface Tack (1-sided)	1	1	—
Density (Bulk Rubber) (g/cc)	1.6	1.6	ASTM D792
Heat Capacity (J/g-K)	1.0	1.0	ASTM E1269
Hardness (Bulk Rubber) (Shore 00) <sup>(1)</sup>	40	40	ASTM D2240
Young's Modulus (psi) / (kPa) <sup>(2)</sup>	100	689	ASTM D575
Continuous Use Temp. (°F) / (°C)	-76 to 392	-60 to 200	—
<b>ELECTRICAL</b>			
Dielectric Breakdown Voltage (Vac.)	>6,000	>6,000	ASTM D149
Dielectric Constant (1,000 Hz)	5.5	5.5	ASTM D150
Volume Resistivity (Ohmmeter)	10 <sup>11</sup>	10 <sup>11</sup>	ASTM D257
Flame Rating	V-0	V-0	UL 94
<b>THERMAL</b>			
Thermal Conductivity (W/m-K)	0.8	0.8	ASTM D5470
<b>THERMAL PERFORMANCE VS. STRAIN</b>			
	Deflection (% strain)		
	10	20	30
Thermal Impedance (°C-in. <sup>2</sup> /W) 0.040 in. <sup>(3)</sup>	2.47	2.37	2.24

1) Thirty-second delay value Shore 00 hardness scale.  
 2) Young's Modulus, calculated using 0.01 in./min. step rate of strain with a sample size of 0.79 in.<sup>2</sup>.  
 3) The ASTM D5470 test fixture was used. The recorded value includes interfacial thermal resistance. These values are provided for reference only. Actual application performance is directly related to the surface roughness, flatness and pressure applied.

### Typical Applications Include:

- Telecommunications
- Computer and peripherals
- Power conversion
- Between heat-generating semiconductors and a heat sink
- Area where heat needs to be transferred to a frame, chassis, or other type of heat spreader
- Between heat-generating magnetic components and a heat sink

### Configurations Available:

- Sheet form and die-cut parts

### Building a Part Number

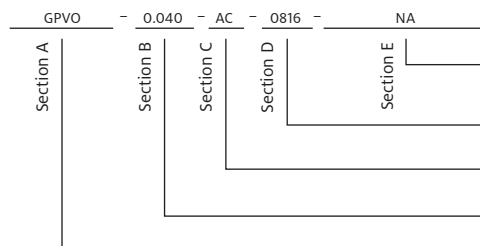

### Standard Options

⚡ example

NA = Selected standard option. If not selecting a standard option, insert company name, drawing number, and revision level.

0816 = Standard sheet size 8" x 16" or 00 = custom configuration

AC = Adhesive on SIL PAD side, natural tack on one side  
 01 = No pressure sensitive adhesive, natural tack on one side

Standard thicknesses available: 0.020", 0.040", 0.060", 0.080", 0.100", 0.125", 0.160", 0.200", 0.250"

GPVO = GAP PAD VO Material

Note: To build a part number, go to [www.bergquistcompany.com/Part\\_Number\\_Builder.php](http://www.bergquistcompany.com/Part_Number_Builder.php).

# GAP PAD VO Soft

## Highly Conformable, Thermally Conductive Material for Filling Air Gaps

### Features and Benefits

- Thermal conductivity: 0.8 W/m-K
- Conformable, low hardness
- Enhanced puncture, shear and tear resistance
- Electrically isolating

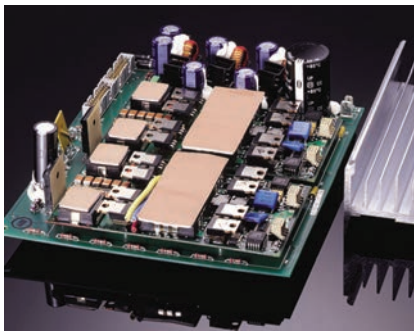

GAP PAD VO Soft is recommended for applications that require a minimum amount of pressure on components. GAP PAD VO Soft is a highly conformable, low-modulus, filled-silicone polymer on a rubber-coated fiberglass carrier. The material can be used as an interface where one side is in contact with a leaded device.

Note: Resultant thickness is defined as the final gap thickness of the application.

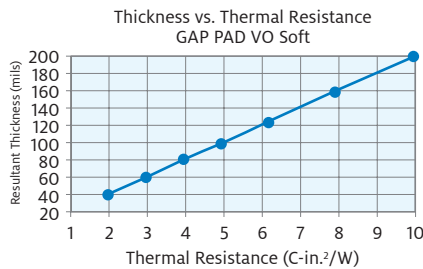

TYPICAL PROPERTIES OF GAP PAD VO SOFT			
PROPERTY	IMPERIAL VALUE	METRIC VALUE	TEST METHOD
Color	Mauve/Pink	Mauve/Pink	Visual
Reinforcement Carrier	SIL PAD	SIL PAD	—
Thickness (in.) / (mm)	0.020 to 0.200	0.508 to 5.080	ASTM D374
Inherent Surface Tack (1-sided)	1	1	—
Density (Bulk Rubber) (g/cc)	1.6	1.6	ASTM D792
Heat Capacity (J/g-K)	1.0	1.0	ASTM E1269
Hardness (Bulk Rubber) (Shore 00) <sup>1)</sup>	25	25	ASTM D2240
Young's Modulus (psi) / (kPa) <sup>2)</sup>	40	275	ASTM D575
Continuous Use Temp. (°F) / (°C)	-76 to 392	-60 to 200	—
<b>ELECTRICAL</b>			
Dielectric Breakdown Voltage (Vac.)	>6,000	>6,000	ASTM D149
Dielectric Constant (1,000 Hz)	5.5	5.5	ASTM D150
Volume Resistivity (Ohmmeter)	10 <sup>11</sup>	10 <sup>11</sup>	ASTM D257
Flame Rating	V-O	V-O	UL 94
<b>THERMAL</b>			
Thermal Conductivity (W/m-K)	0.8	0.8	ASTM D5470
<b>THERMAL PERFORMANCE VS. STRAIN</b>			
	Deflection (% strain)		
	10	20	30
Thermal Impedance (°C-in.²/W) 0.040 in. <sup>3)</sup>	2.48	2.29	2.11
<small>1) Thirty-second delay value Shore 00 hardness scale.                  2) Young's Modulus, calculated using 0.01 in./min. step rate of strain with a sample size of 0.79 in.².                  3) The ASTM D5470 test fixture was used. The recorded value includes interfacial thermal resistance. These values are provided for reference only. Actual application performance is directly related to the surface roughness, flatness and pressure applied.</small>			

### Typical Applications Include:

- Telecommunications
- Computer and peripherals
- Power conversion
- Between heat-generating semiconductors or magnetic components and a heat sink
- Area where heat needs to be transferred to a frame, chassis, or other type of heat spreader

### Configurations Available:

- Sheet form and die-cut parts

### Building a Part Number

GPVOS - 0.060 - AC - 00 - ACME10256 Rev. a

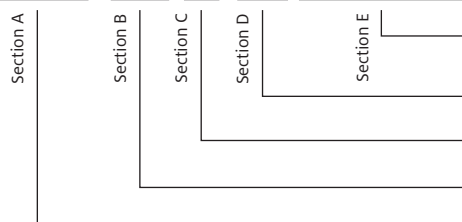

### Standard Options

◀ example

NA = Selected standard option. If not selecting a standard option, insert company name, drawing number, and revision level.

0816 = Standard sheet size 8" x 16", or  
00 = custom configuration

AC = Adhesive on SIL-PAD side, natural tack on one side  
01 = No pressure sensitive adhesive, natural tack on one side

Standard thicknesses available: 0.020", 0.040", 0.060", 0.080", 0.100", 0.125", 0.160", 0.200"

GPVOS = GAP PAD VO Soft Material

Note: To build a part number, go to [www.bergquistcompany.com/Part\\_Number\\_Builder.php](http://www.bergquistcompany.com/Part_Number_Builder.php).

# GAP PAD VO Ultra Soft

## Ultra Conformable, Thermally Conductive Material for Filling Air Gaps

### Features and Benefits

- Thermal conductivity: 1.0 W/m-K
- Highly conformable, low hardness
- “Gel-like” modulus
- Decreased strain
- Puncture-, shear- and tear-resistant
- Electrically isolating



GAP PAD VO Ultra Soft is recommended for applications that require a minimum amount of pressure on components. The viscoelastic nature of the material also gives excellent low-stress vibration dampening and shock absorbing characteristics. GAP PAD VO Ultra Soft is an electrically isolating material, which allows its use in applications requiring isolation between heat sinks and high-voltage, bare-leaded devices.

Note: Resultant thickness is defined as the final gap thickness of the application.

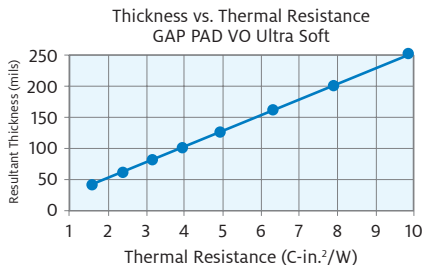

TYPICAL PROPERTIES OF GAP PAD VO ULTRA SOFT				
PROPERTY	IMPERIAL VALUE	METRIC VALUE	TEST METHOD	
Color	Mauve/Pink	Mauve/Pink	Visual	
Reinforcement Carrier	SIL PAD	SIL PAD	—	
Thickness (in.) / (mm)	0.020 to 0.250	0.508 to 6.350	ASTM D374	
Inherent Surface Tack (1-sided)	1	1	—	
Density (Bulk Rubber) (g/cc)	1.6	1.6	ASTM D792	
Heat Capacity (J/g-K)	1.0	1.0	ASTM E1269	
Hardness (Bulk Rubber) (Shore 00) <sup>1)</sup>	5	5	ASTM D2240	
Young's Modulus (psi) / (kPa) <sup>2)</sup>	8	55	ASTM D575	
Continuous Use Temp. (°F) / (°C)	-76 to 392	-60 to 200	—	
<b>ELECTRICAL</b>				
Dielectric Breakdown Voltage (Vac.)	6,000	6,000	ASTM D149	
Dielectric Constant (1,000 Hz)	5.5	5.5	ASTM D150	
Volume Resistivity (Ohmmeter)	10 <sup>11</sup>	10 <sup>11</sup>	ASTM D257	
Flame Rating	V-0	V-0	UL 94	
<b>THERMAL</b>				
Thermal Conductivity (W/m-K)	1.0	1.0	ASTM D5470	
<b>THERMAL PERFORMANCE VS. STRAIN</b>				
	Deflection (% strain)	10	20	30
	Thermal Impedance (°C-in.²/W) 0.040 in. <sup>3)</sup>	1.97	1.87	1.68

1) Thirty-second delay value Shore 00 hardness scale.  
 2) Young's Modulus, calculated using 0.01 in./min. step rate of strain with a sample size of 0.79 in.<sup>2</sup>.  
 3) The ASTM D5470 test fixture was used. The recorded value includes interfacial thermal resistance. These values are provided for reference only. Actual application performance is directly related to the surface roughness, flatness and pressure applied.

### Typical Applications Include:

- Telecommunications
- Computer and peripherals
- Power conversion
- Between heat-generating semiconductors or magnetic components and a heat sink
- Area where heat needs to be transferred to a frame, chassis, or other type of heat spreader

### Configurations Available:

- Sheet form and die-cut parts

### Building a Part Number

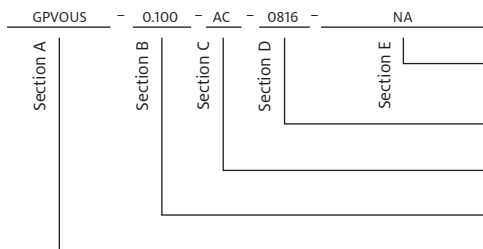

### Standard Options

◀ example

NA = Selected standard option. If not selecting a standard option, insert company name, drawing number, and revision level.

0816 = Standard sheet size 8" x 16", or 00 = custom configuration

AC = Adhesive on SIL-PAD side, natural tack on one side  
 01 = No pressure sensitive adhesive, natural tack on one side

Standard thicknesses available: 0.020", 0.040", 0.060", 0.080", 0.100", 0.125", 0.160", 0.200", 0.250"

GPV00S = GAP PAD VO Ultra Soft Material

Note: To build a part number, go to [www.bergquistcompany.com/Part\\_Number\\_Builder.php](http://www.bergquistcompany.com/Part_Number_Builder.php).

# GAP PAD HC 3.0

## High-Compliance, Thermally Conductive, Low Modulus Material

### Features and Benefits

- Thermal conductivity: 3.0 W/m-K
- High-compliance, low compression stress
- Fiberglass-reinforced for shear and tear resistance

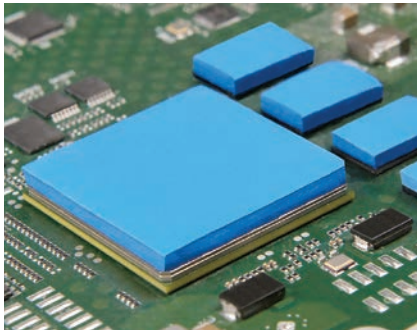

GAP PAD HC 3.0 is a soft and compliant gap filling material with a thermal conductivity of 3.0 W/m-K. The material offers exceptional thermal performance at low pressures due to a unique 3.0 W/m-K filler package and low-modulus resin formulation. The enhanced material is ideal for applications requiring low stress on components and boards during assembly. GAP PAD HC 3.0 maintains a conformable nature that allows for quick recovery and excellent wet-out characteristics, even to surfaces with high roughness and/or topography.

GAP PAD HC 3.0 is offered with natural inherent tack on both sides of the material, eliminating the need for thermally impeding adhesive layers. The top side has minimal tack for ease of handling. GAP PAD HC 3.0 is supplied with protective liners on both sides.

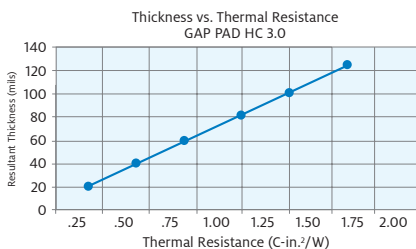

TYPICAL PROPERTIES OF GAP PAD HC 3.0			
PROPERTY	IMPERIAL VALUE	METRIC VALUE	TEST METHOD
Color	Blue	Blue	Visual
Reinforcement Carrier	Fiberglass	Fiberglass	—
Thickness (in.) / (mm)	0.020 to 0.125	0.508 to 3.175	ASTM D374
Inherent Surface Tack	2	2	—
Density (Bulk Rubber) (g/cc)	3.1	3.1	ASTM D792
Heat Capacity (J/g-K)	1.0	1.0	ASTM E1269
Hardness (Bulk Rubber) (Shore 00) <sup>(4)</sup>	15	15	ASTM D2240
Young's Modulus (psi) / (kPa) <sup>(1)</sup>	16	110	ASTM D575
Continuous Use Temp. (°F) / (°C)	-76 to 392	-60 to 200	—
<b>ELECTRICAL</b>			
Dielectric Breakdown Voltage (Vac.) <sup>(3)</sup>	>5,000	>5,000	ASTM D149
Dielectric Constant (1,000 Hz)	6.5	6.5	ASTM D150
Volume Resistivity (Ohmmeter)	10 <sup>10</sup>	10 <sup>10</sup>	ASTM D257
Flame Rating	V-O	V-O	UL 94
<b>THERMAL</b>			
Thermal Conductivity (W/m-K) <sup>(2)</sup>	3.0	3.0	ASTM D5470
<b>THERMAL PERFORMANCE VS. STRAIN</b>			
	Deflection (% strain)		
	10	20	30
Thermal Impedance (°C-in.²/W) 0.040 in. <sup>(2)</sup>	0.57	0.49	0.44
<small>1) Young's Modulus, calculated using 0.01 in./min. step rate of strain with a sample size of 0.79 in.² after 5 minutes of compression at 10% strain on a 1 mm thickness material.                  2) The ASTM D5470 test fixture was used. The recorded value includes interfacial thermal resistance. These values are provided for reference only. Actual application performance is directly related to the surface roughness, flatness and pressure applied.                  3) Minimum value at 20 mil.                  4) Thirty-second delay value on Shore 00 hardness scale.</small>			

### Typical Applications Include:

- Telecommunications
- ASICs and DSPs
- Consumer electronics
- Thermal modules to heat sinks

### Configurations Available:

- Sheet form and die-cut parts

### Building a Part Number

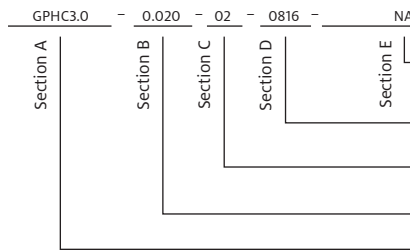

### Standard Options

◀ **example**

NA = Selected standard option. If not selecting a standard option, insert company name, drawing number, and revision level.

0816 = Standard sheet size 8" x 16", or  
00 = custom configuration

02 = Natural tack, both sides (With fiberglass)

Standard thicknesses available: 0.020", 0.040", 0.060", 0.080", 0.100", 0.125"

GPHC3.0 = GAP PAD HC 3.0 Material with fiberglass

Note: To build a part number, go to [www.bergquistcompany.com/Part\\_Number\\_Builder.php](http://www.bergquistcompany.com/Part_Number_Builder.php).



# GAP PAD HC 5.0

## Highly Conformable, Thermally Conductive, Low Modulus Material

### Features and Benefits

- Thermal conductivity: 5.0 W/m-K
- High-compliance, low compression stress
- Fiberglass reinforced for shear and tear resistance

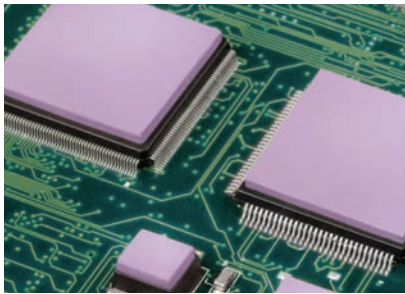

GAP PAD HC 5.0 is a soft and compliant gap filling material with a thermal conductivity of 5.0 W/m-K. The material offers exceptional thermal performance at low pressures due to a unique filler package and low-modulus resin formulation. The enhanced material is ideal for applications requiring low stress on components and boards during assembly. GAP PAD HC 5.0 maintains a conformable nature that allows for excellent interfacing and wet-out characteristics, even to surfaces with high roughness and/or topography.

GAP PAD HC 5.0 is offered with natural inherent tack on both sides of the material, eliminating the need for thermally-impeding adhesive layers. The top side has minimal tack for ease of handling. GAP PAD HC 5.0 is supplied with protective liners on both sides.

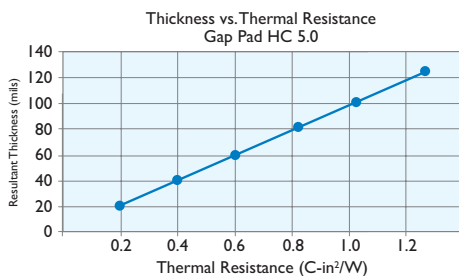

### TYPICAL PROPERTIES OF GAP PAD HC 5.0

PROPERTY	IMPERIAL VALUE	METRIC VALUE	TEST METHOD	
Color	Violet	Violet	Visual	
Reinforcement Carrier	Fiberglass	Fiberglass	—	
Thickness (in.) / (mm)*	0.020, 0.040, 0.060 0.080, 0.100, 0.125	0.508, 1.016, 1.524, 2.032, 2.540, 3.175	ASTM D374	
Inherent Surface Tack	2	2	—	
Density (Bulk Rubber) (g/cc)	3.2	3.2	ASTM D792	
Heat Capacity (J/g-K)	1.0	1.0	ASTM E1269	
Hardness (Bulk Rubber) (Shore 00) <sup>(4)</sup>	35	35	ASTM D2240	
Young's Modulus (psi) / (kPa) <sup>(1)</sup>	17.5	121	ASTM D575	
Typical Use Temp. (°F) / (°C)	-76 to 392	-60 to 200	—	
<b>ELECTRICAL</b>				
Dielectric Breakdown Voltage (Vac.) <sup>(3)</sup>	5000	5000	ASTM D149	
Dielectric Constant (1,000 Hz)	8.0	8.0	ASTM D150	
Volume Resistivity (Ohmmeter)	10 <sup>10</sup>	10 <sup>10</sup>	ASTM D257	
Flame Rating	V-O	V-O	UL 94	
<b>THERMAL</b>				
Thermal Conductivity (W/m-K) <sup>(2)</sup>	5.0	5.0	ASTM D5470	
<b>THERMAL PERFORMANCE VS. STRAIN</b>				
	Deflection (% strain)	10	20	30
	Thermal Impedance (°C-in. <sup>2</sup> /W) 0.040 in. <sup>(2)</sup>	0.35	0.30	0.26

\* Custom thicknesses available. Please contact your Henkel Sales Representative for more information.  
 (1) Young's Modulus, calculated using 0.01 in/min. step rate of strain with a sample size of 0.79 inch<sup>2</sup> after 5 minutes of compression at 10% strain on a 1mm thickness material.  
 (2) The ASTM D5470 test fixture was used. The recorded value includes interfacial thermal resistance. These values are provided for reference only. Actual application performance is directly related to the surface roughness, flatness and pressure applied.  
 (3) Minimum value at 20 mil.  
 (4) Thirty second delay value on Shore 00 hardness scale.

### Typical Applications Include:

- Telecommunications
- ASICs and DSPs
- Consumer electronics
- Thermal modules to heat sinks

### Configurations Available:

- Sheet form and die-cut parts

### Building a Part Number

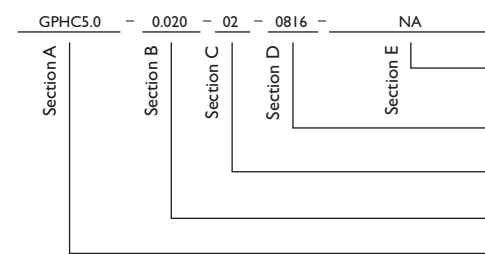

### Standard Options

◀ example

NA = Selected standard option. If not selecting a standard option, insert company name, drawing number, and revision level.

0816 = Standard sheet size 8" x 16", or  
00 = custom configuration

02 = Natural tack, both sides (With Fiberglass)

Standard thicknesses available: 0.020", 0.040", 0.060", 0.080", 0.100", 0.125"

GPHC5.0 = Gap Pad HC 5.0 Material with fiberglass

Note: To build a part number, go to [www.bergquistcompany.com/Part\\_Number\\_Builder.php](http://www.bergquistcompany.com/Part_Number_Builder.php).

# GAP PAD 1000HD

Highly Durable, Conformable, Thermally Conductive, Gap Filling Material

## Features and Benefits

- Thermal conductivity: 1.0 W/m-K
- Designed for high durability applications
- Robust polyimide carrier provides excellent voltage breakdown, puncture and tear resistance
- Highly conformable
- Ease of handling and rework in applications

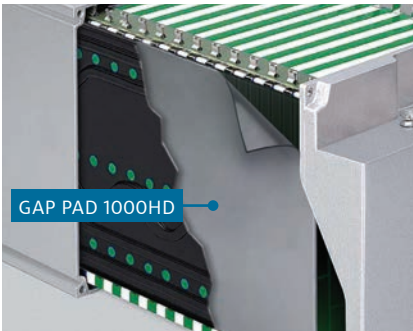

GAP PAD 1000HD was designed to withstand applications requiring high durability.

The coated polyimide carrier on one side of the material allows easy rework, excellent handling characteristics and puncture resistance.

The conformable and elastic nature of GAP PAD 1000HD allows excellent interfacing and wet-out characteristics, even to surfaces with a high degree of roughness or uneven topography.

The asymmetric construction of GAP PAD 1000HD provides minimal tack on the polyimide side, with high inherent tack on the upcoated side. GAP PAD 1000HD can be assembled with manual or automated processes.

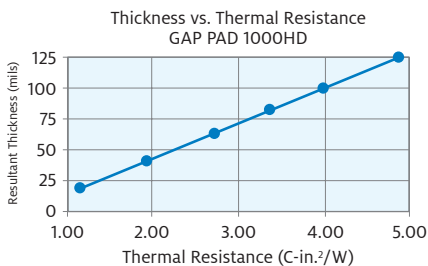

TYPICAL PROPERTIES OF GAP PAD 1000HD				
PROPERTY	IMPERIAL VALUE	METRIC VALUE	TEST METHOD	
Color	Grey/Black	Grey/Black	Visual	
Reinforcement Carrier	Polyimide	Polyimide	—	
Thickness (in.) / (mm)	0.020 to 0.125	0.508 to 3.175	ASTM D374	
Inherent Surface Tack (1- or 2-sided)	1	1	—	
Density (g/cc)	2.1	2.1	ASTM D792	
Heat Capacity (J/g-K)	1.0	1.0	ASTM E1269	
Hardness, Bulk Rubber (Shore 00) <sup>(1)</sup>	40	40	ASTM D2240	
Young's Modulus (psi) / (kPa) <sup>(2)</sup>	60	414	ASTM D575	
Continuous Use Temp. (°C)	-76 to 358	-60 to 180	—	
<b>ELECTRICAL</b>				
Dielectric Breakdown Voltage (Vac.)	>10,000	>10,000	ASTM D149	
Dielectric Constant (1,000 Hz)	5.5	5.5	ASTM D150	
Volume Resistivity (Ohmmeter)	10 <sup>11</sup>	10 <sup>11</sup>	ASTM D257	
Flame Rating	V-O	V-O	UL 94	
<b>THERMAL</b>				
Thermal Conductivity (W/m-K)	1.0	1.0	ASTM D5470	
<b>THERMAL PERFORMANCE VS. STRAIN</b>				
	Deflection (% strain)	10	20	30
	Thermal Impedance (°C-in. <sup>2</sup> /W) 0.040 in. <sup>(3)</sup>	1.70	1.59	1.47

1) Thirty-second delay value Shore 00 hardness scale.  
 2) Young's Modulus, calculated using 0.01 in./min. step rate of strain with a sample size of 0.79 in.<sup>2</sup>.  
 3) The ASTM D5470 test fixture was used. The recorded values includes interfacial thermal resistance. These values are provided for reference only. Actual application performance is directly related to the surface roughness, flatness and pressure applied.

## Typical Applications Include:

- High durability applications
- Automotive energy storage: ultra capacitors, batteries, power transmissions, power inverters
- Industrial automotive applications such as trucks, buses and trains
- Computer and peripherals
- Telecommunications
- Between any heat-generating device and a heat sink

## Configurations Available:

- Sheet form
- Die-cut parts

## Building a Part Number

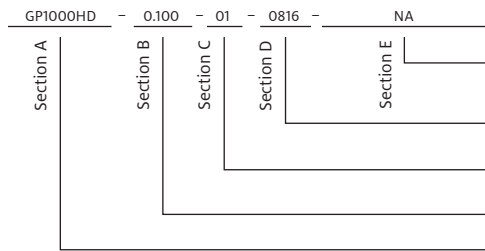

## Standard Options

NA = Selected standard option. If not selecting a standard option, insert company name, drawing number, and revision level.

0816 = Standard sheet size 8" x 16", or 00 = custom configuration

01 = Natural tack on one side

Standard thicknesses available: 0.020", 0.040", 0.060", 0.080", 0.100", 0.125"

GP1000HD = GAP PAD 1000HD Material

Note: To build a part number, go to [www.bergquistcompany.com/Part\\_Number\\_Builder.php](http://www.bergquistcompany.com/Part_Number_Builder.php).

# GAP PAD 1000SF

## Thermally Conductive, Silicone-Free Gap Filling Material

### Features and Benefits

- Thermal conductivity: 0.9 W/m-K
- No silicone outgassing
- No silicone extraction
- Reduced tack on one side to aid in application assembly
- Electrically isolating

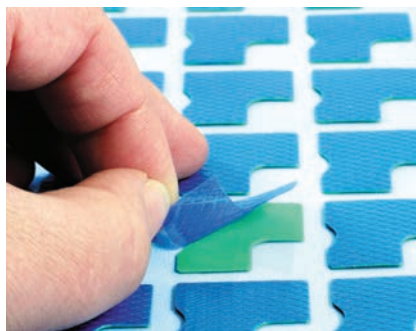

GAP PAD 1000SF is a thermally conductive, electrically insulating, silicone-free polymer specially designed for silicone-sensitive applications. The material is ideal for applications with high standoff and flatness tolerances. GAP PAD 1000SF is reinforced for easy material handling and added durability during assembly. The material is available with a protective liner on both sides of the material. The top side has reduced tack for ease of handling.

Note: Resultant thickness is defined as the final gap thickness of the application.

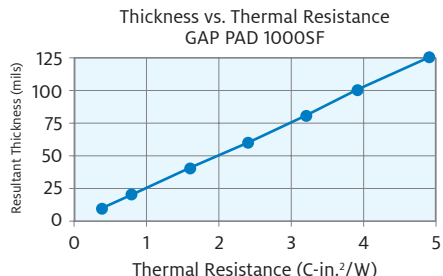

TYPICAL PROPERTIES OF GAP PAD 1000SF			
PROPERTY	IMPERIAL VALUE	METRIC VALUE	TEST METHOD
Color	Green	Green	Visual
Reinforcement Carrier	Fiberglass	Fiberglass	—
Thickness (in.) / (mm)	0.010 to 0.125	0.254 to 3.175	ASTM D374
Inherent Surface Tack (1- or 2-sided)	2	2	—
Density (g/cc)	2.0	2.0	ASTM D792
Heat Capacity (J/g-K)	1.1	1.1	ASTM E1269
Hardness, Bulk Rubber (Shore 00) <sup>(1)</sup>	40	40	ASTM D2240
Young's Modulus (psi) / (kPa) <sup>(2)</sup>	34	234	ASTM D575
Continuous Use Temp. (°F) / (°C)	-76 to 257	-60 to 125	—
<b>ELECTRICAL</b>			
Dielectric Breakdown Voltage (Vac.)	>6,000	>6,000	ASTM D149
Dielectric Constant (1,000 Hz)	5.0	5.0	ASTM D150
Volume Resistivity (Ohmmeter)	10 <sup>10</sup>	10 <sup>10</sup>	ASTM D257
Flame Rating	V-1	V-1	UL 94
<b>THERMAL</b>			
Thermal Conductivity (W/m-K)	0.9	0.9	ASTM D5470

1) Thirty-second delay value Shore 00 hardness scale.  
 2) Young's Modulus, calculated using 0.01 in./min. step rate of strain with a sample size of 0.79 in.<sup>2</sup>. For more information on GAP PAD modulus, refer to BERGQUIST Application Note #116 at our website's Technical Library.

### Typical Applications Include:

- Digital disk drives / CD-ROM
- Automotive modules
- Fiber optics modules

### Configurations Available:

- Sheet form
- Die-cut parts

### Building a Part Number

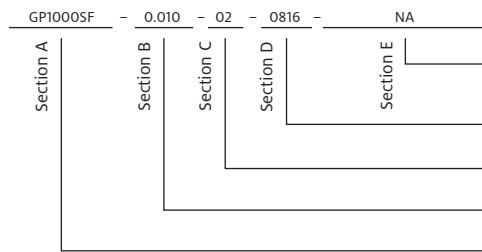

### Standard Options

◀ example  
 NA = Selected standard option. If not selecting a standard option, insert company name, drawing number, and revision level.  
 0806 = Standard sheet size 8" x 16", or 00 = custom configuration  
 02 = Natural tack, both sides  
 Standard thicknesses available: 0.010", 0.015", 0.020", 0.040", 0.060", 0.080", 0.100", 0.125"  
 GP1000SF = GAP PAD 1000SF Material

Note: To build a part number, go to [www.bergquistcompany.com/Part\\_Number\\_Builder.php](http://www.bergquistcompany.com/Part_Number_Builder.php).

# GAP PAD HC1000

## “Gel-Like” Modulus Gap Filling Material

### Features and Benefits

- Thermal conductivity: 1.0 W/m-K
- Highly conformable, low hardness
- “Gel-like” modulus
- Fiberglass-reinforced for puncture, shear and tear resistance

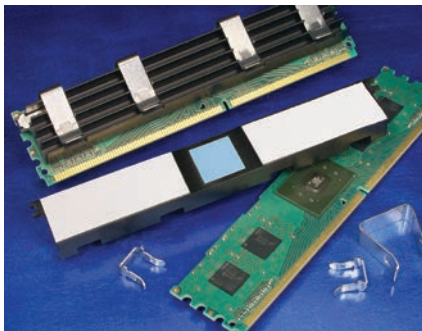

GAP PAD HC1000 is an extremely conformable, low-modulus polymer that acts as a thermal interface and electrical insulator between electronic components and heat sinks. The “gel-like” modulus allows this material to fill air gaps to enhance the thermal performance of electronic systems. GAP PAD HC1000 is offered with removable protective liners on both sides of the material.

Note: Resultant thickness is defined as the final gap thickness of the application.

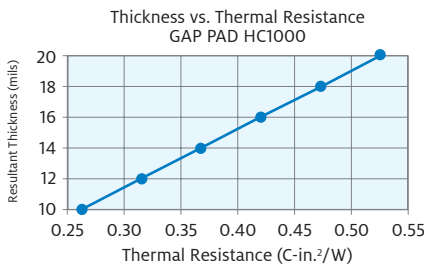

### TYPICAL PROPERTIES OF GAP PAD HC1000

PROPERTY	IMPERIAL VALUE	METRIC VALUE	TEST METHOD
Color	Grey	Grey	Visual
Reinforcement Carrier	Fiberglass	Fiberglass	—
Thickness (in.) / (mm)	0.010 to 0.020	0.254 to 0.508	ASTM D374
Inherent Surface Tack (1-sided)	2	2	—
Density (Bulk Rubber) (g/cc)	1.6	1.6	ASTM D792
Heat Capacity (J/g-K)	1.0	1.0	ASTM E1269
Hardness (Bulk Rubber) (Shore 00) <sup>(1)</sup>	25	25	ASTM D2240
Young's Modulus (psi) / (kPa) <sup>(2)</sup>	40	275	ASTM D575
Continuous Use Temp. (°F) / (°C)	-76 to 392	-60 to 200	—
<b>ELECTRICAL</b>			
Dielectric Breakdown Voltage (Vac.)	>5,000	>5,000	ASTM D149
Dielectric Constant (1,000 Hz)	5.5	5.5	ASTM D150
Volume Resistivity (Ohmmeter)	10 <sup>11</sup>	10 <sup>11</sup>	ASTM D257
Flame Rating	V-O	V-O	UL 94
<b>THERMAL</b>			
Thermal Conductivity (W/m-K)	1.0	1.0	ASTM D5470
<b>THERMAL PERFORMANCE VS. STRAIN</b>			
	Deflection (% strain)		
	10	20	30
Thermal Impedance (°C-in. <sup>2</sup> /W) 0.020 in. <sup>(3)</sup>	1.30	1.00	0.96
<small>1) Thirty-second delay value Shore 00 hardness scale.                  2) Young's Modulus, calculated using 0.01 in./min. step rate of strain with a sample size of 0.79 in.<sup>2</sup>.                  3) The ASTM D5470 test fixture was used. The recorded value includes interfacial thermal resistance. These values are provided for reference only. Actual application performance is directly related to the surface roughness, flatness and pressure applied.</small>			

### Typical Applications Include:

- Computer and peripherals
- Telecommunications
- Heat interfaces to frames, chassis, or other heat spreading devices
- Memory modules / chip scale packages
- CD-ROM / DVD cooling
- Areas where irregular surfaces need to make a thermal interface to a heat sink
- DDR SDRAM memory modules
- FB-DIMM modules

### Configurations Available:

- Sheet form, die-cut parts, and roll form (converted or unconverted)

### Building a Part Number

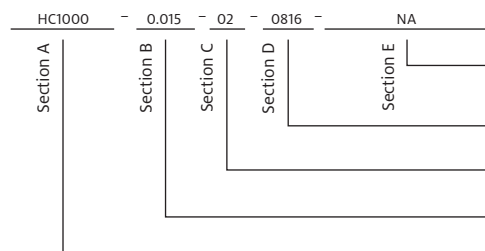

### Standard Options

- ◀ example
- NA = Selected standard option. If not selecting a standard option, insert company name, drawing number, and revision level.
- 0816 = Standard sheet size 8" x 16", or  
00 = custom configuration
- 02 = Natural tack, both sides
- Standard thicknesses available: 0.010", 0.015", 0.020"
- HC1000 = High Compliance 1000 Material

Note: To build a part number, go to [www.bergquistcompany.com/Part\\_Number\\_Builder.php](http://www.bergquistcompany.com/Part_Number_Builder.php).

# GAP PAD 1450

## Highly Conformable, Thermally Conductive, Reworkable Gap Filling Material

### Features and Benefits

- Thermal conductivity: 1.3 W/m-K (bulk rubber)
- PEN film reinforcement allows easy rework and resistance to puncture and tear resistance
- Highly conformable/low hardness
- Low strain on fragile components



GAP PAD 1450 is a highly compliant GAP PAD material that is ideal for fragile component leads. The material includes a PEN film, which facilitates rework and improves puncture resistance and handling characteristics. The tacky side of GAP PAD 1450 maintains a conformable, yet elastic nature that provides excellent interfacing and wet-out characteristics, even to surfaces with high roughness or uneven topography.

GAP PAD 1450 has inherent tack on one side of the material, eliminating the need for thermally impeding adhesive layers.

It is highly recommended that the PEN film be left intact. However, film removal will not have a significant impact on thermal performance.

Please contact your local Henkel Sales Representative for sample inquiries and additional product information.

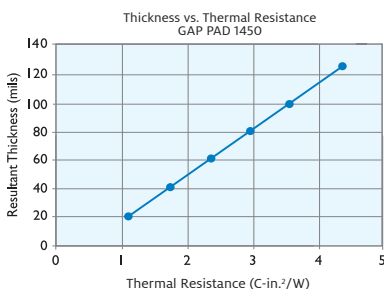

### TYPICAL PROPERTIES OF GAP PAD 1450

PROPERTY	IMPERIAL VALUE	METRIC VALUE	TEST METHOD
Color	Light Pink	Light Pink	Visual
Reinforcement Carrier	PEN film	PEN film	—
Thickness (in.) / (mm)	0.020 to 0.125	0.508 to 3.175	ASTM D374
Inherent Surface Tack (1-sided)	1	1	—
Density (Bulk Rubber) (g/cc)	1.8	1.8	ASTM D792
Heat Capacity (J/g-K)	1.0	1.0	ASTM E1269
Hardness (Bulk Rubber) (Shore 00) <sup>(1)</sup>	30	30	ASTM D2240
Young's Modulus (psi) / (kPa) <sup>(2)</sup>	16	110	ASTM D575
Continuous Use Temp. (°F) / (°C)	-76 to 302	-60 to 150	—
<b>ELECTRICAL</b>			
Dielectric Breakdown Voltage (Vac.)	>6,000	>6,000	ASTM D149
Dielectric Constant (1,000 Hz)	5.0	5.0	ASTM D150
Volume Resistivity (Ohmmeter)	10 <sup>9</sup>	10 <sup>9</sup>	ASTM D257
Flame Rating	V-0	V-0	UL 94
<b>THERMAL</b>			
Thermal Conductivity (W/m-K)	1.3	1.3	ASTM D5470

1) Thirty-second delay value Shore 00 hardness scale.  
2) Young's Modulus, calculated using 0.01 in./min. step rate of strain with a sample size of 0.79 in.<sup>2</sup>.

### Typical Applications:

- Lighting and LED applications
- Low strain is required for fragile component leads
- Computer and peripherals
- Telecommunications
- Between any heat-generating semiconductor and a heat sink

### Configurations Available:

- Sheet form and die-cut parts

### Building a Part Number

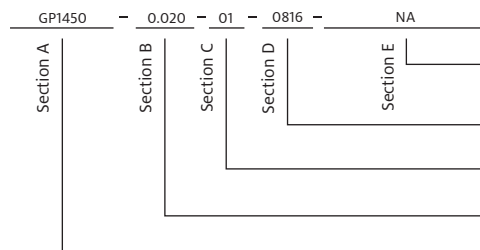

### Standard Options

- ◀ example
- NA = Selected standard option. If not selecting a standard option, insert company name, drawing number, and revision level.
- 0816 = Standard sheet size 8" x 16", or 00 = custom configuration
- 01 = Natural tack, one side
- Standard thickness available: 0.020", 0.040", 0.060", 0.080", 0.100", 0.125"
- GP1450 = GAP PAD 1450 Material

Note: To build a part number, go to [www.bergquistcompany.com/Part\\_Number\\_Builder.php](http://www.bergquistcompany.com/Part_Number_Builder.php).

# GAP PAD 1500

## Thermally Conductive, Unreinforced Gap Filling Material

### Features and Benefits

- Thermal conductivity: 1.5 W/m-K
- Unreinforced construction for additional compliancy
- Conformable, low hardness
- Electrically isolating



GAP PAD 1500 has an ideal filler blend that gives it a low-modulus characteristic which maintains optimal thermal performance yet still allows for easy handling. The natural tack on both sides of the material allows for good compliance to adjacent surfaces of components, minimizing interfacial resistance.

Note: Resultant thickness is defined as the final gap thickness of the application.

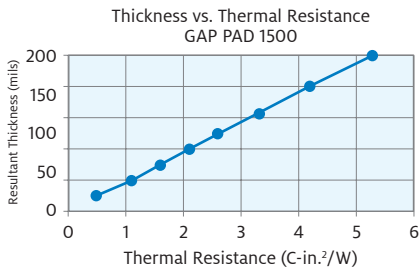

TYPICAL PROPERTIES OF GAP PAD 1500					
PROPERTY	IMPERIAL VALUE	METRIC VALUE	TEST METHOD		
Color	Black	Black	Visual		
Reinforcement Carrier	—	—	—		
Thickness (in.) / (mm)	0.020 to 0.200	0.508 to 5.080	ASTM D374		
Inherent Surface Tack (1-sided)	2	2	—		
Density (Bulk Rubber) (g/cc)	2.1	2.1	ASTM D792		
Heat Capacity (J/g-K)	1.0	1.0	ASTM E1269		
Hardness (Bulk Rubber) (Shore 00) <sup>(1)</sup>	40	40	ASTM D2240		
Young's Modulus (psi) / (kPa) <sup>(2)</sup>	45	310	ASTM D575		
Continuous Use Temp. (°F) / (°C)	-76 to 392	-60 to 200	—		
<b>ELECTRICAL</b>					
Dielectric Breakdown Voltage (Vac.)	>6,000	>6,000	ASTM D149		
Dielectric Constant (1,000 Hz)	5.5	5.5	ASTM D150		
Volume Resistivity (Ohmmeter)	10 <sup>11</sup>	10 <sup>11</sup>	ASTM D257		
Flame Rating	V-O	V-O	UL 94		
<b>THERMAL</b>					
Thermal Conductivity (W/m-K)	1.5	1.5	ASTM D5470		
<b>THERMAL PERFORMANCE VS. STRAIN</b>					
	Deflection (% strain)		10	20	30
	Thermal Impedance (°C-in.²/W) 0.040 in. <sup>(3)</sup>		1.62	1.50	1.33

1) Thirty-second delay value Shore 00 hardness scale.  
 2) Young's Modulus, calculated using 0.01 in./min. step rate of strain with a sample size of 0.79 in.<sup>2</sup>.  
 3) The ASTM D5470 test fixture was used. The recorded value includes interfacial thermal resistance. These values are provided for reference only. Actual application performance is directly related to the surface roughness, flatness and pressure applied.

### Typical Applications Include:

- Telecommunications
- Computer and peripherals
- Power conversion
- Memory modules / chip scale packages
- Areas where heat needs to be transferred to a frame chassis or other type of heat spreader

### Configurations Available:

- Sheet form and die-cut parts

### Building a Part Number

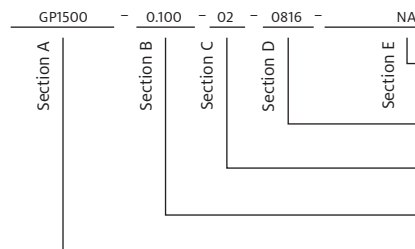

### Standard Options

◀ example

NA = Selected standard option. If not selecting a standard option, insert company name, drawing number, and revision level.

0816 = Standard sheet size 8" x 16", or 00 = custom configuration

02 = Natural tack, both sides

Standard thicknesses available: 0.020", 0.040", 0.060", 0.080", 0.100", 0.125", 0.160", 0.200"

GP1500 = GAP PAD 1500 Material

Note: To build a part number, go to [www.bergquistcompany.com/Part\\_Number\\_Builder.php](http://www.bergquistcompany.com/Part_Number_Builder.php).



# GAP PAD 1500R

## Thermally Conductive, Reinforced Gap Filling Material

### Features and Benefits

- Thermal conductivity: 1.5 W/m-K
- Fiberglass-reinforced for puncture, shear and tear resistance
- Easy release construction
- Electrically isolating



GAP PAD 1500R has the same highly conformable, low-modulus polymer as the standard GAP PAD 1500. The fiberglass reinforcement allows for easy material handling and enhances puncture, shear and tear resistance. The natural tack on both sides of the material allows for good compliance to mating surfaces of components, further reducing thermal resistance.

Note: Resultant thickness is defined as the final gap thickness of the application.

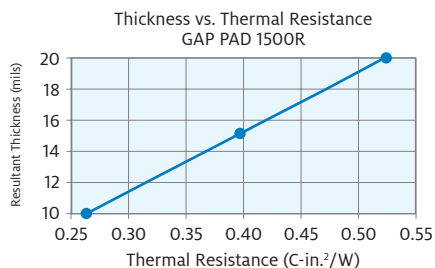

TYPICAL PROPERTIES OF GAP PAD 1500R				
PROPERTY	IMPERIAL VALUE	METRIC VALUE	TEST METHOD	
Color	Black	Black	Visual	
Reinforcement Carrier	Fiberglass	Fiberglass	—	
Thickness (in.) / (mm)	0.010 to 0.020	0.254 to 0.508	ASTM D374	
Inherent Surface Tack (1-sided)	2	2	—	
Density (Bulk Rubber) (g/cc)	2.1	2.1	ASTM D792	
Heat Capacity (J/g-K)	1.3	1.3	ASTM E1269	
Hardness (Bulk Rubber) (Shore 00) <sup>(1)</sup>	40	40	ASTM D2240	
Young's Modulus (psi) / (kPa) <sup>(2)</sup>	45	310	ASTM D575	
Continuous Use Temp. (°F) / (°C)	-76 to 392	-60 to 200	—	
ELECTRICAL				
Dielectric Breakdown Voltage (Vac.)	>6,000	>6,000	ASTM D149	
Dielectric Constant (1,000 Hz)	6.0	6.0	ASTM D150	
Volume Resistivity (Ohmmeter)	10 <sup>11</sup>	10 <sup>11</sup>	ASTM D257	
Flame Rating	V-O	V-O	UL 94	
THERMAL				
Thermal Conductivity (W/m-K)	1.5	1.5	ASTM D5470	
THERMAL PERFORMANCE VS. STRAIN				
	Deflection (% strain)	10	20	30
	Thermal Impedance (°C-in. <sup>2</sup> /W) 0.020 in. <sup>(3)</sup>	1.07	0.88	0.82
<small>1) Thirty-second delay value Shore 00 hardness scale.                  2) Young's Modulus, calculated using 0.01 in./min. step rate of strain with a sample size of 0.79 in.<sup>2</sup>.                  3) The ASTM D5470 test fixture was used. The recorded value includes interfacial thermal resistance. These values are provided for reference only. Actual application performance is directly related to the surface roughness, flatness and pressure applied.</small>				

### Typical Applications Include:

- Telecommunications
- Computer and peripherals
- Power conversion
- Memory modules / chip scale packages
- Areas where heat needs to be transferred to a frame chassis or other type of heat spreader

### Configurations Available:

- Sheet form, die-cut parts, and roll form (converted or unconverted)

### Building a Part Number

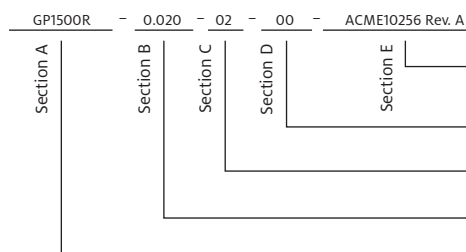

### Standard Options

- ◀ example
- NA = Selected standard option. If not selecting a standard option, insert company name, drawing number, and revision level.
  - O816 = Standard sheet size 8" x 16", or 00 = custom configuration
  - 02 = Natural tack, both sides
  - Standard thicknesses available: 0.010", 0.015", 0.020"
  - GP1500R = GAP PAD 1500R Material

Note: To build a part number, go to [www.bergquistcompany.com/Part\\_Number\\_Builder.php](http://www.bergquistcompany.com/Part_Number_Builder.php).

# GAP PAD 1500S30

Highly Conformable, Thermally Conductive, Reinforced “S-Class” Gap Filling Material

## Features and Benefits

- Thermal conductivity: 1.3 W/m-K
- Highly conformable/low hardness
- Decreased strain on fragile components
- Fiberglass-reinforced for puncture, shear and tear resistance
- Quick rebound to original shape

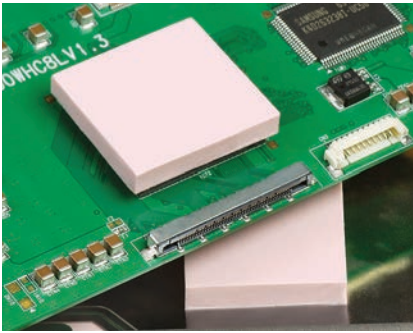

GAP PAD 1500S30 is a highly compliant GAP PAD material that is ideal for fragile component leads. The material is fiberglass-reinforced for improved puncture resistance and handling characteristics. GAP PAD 1500S30 maintains a conformable, yet elastic nature that provides excellent interfacing and wet-out characteristics, even to surfaces with high roughness or uneven topography.

GAP PAD 1500S30 features an inherent tack on both sides of the material, eliminating the need for thermally impeding adhesive layers.

Note: Resultant thickness is defined as the final gap thickness of the application.

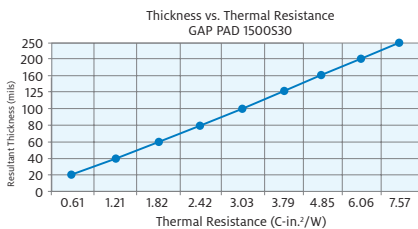

## TYPICAL PROPERTIES OF GAP PAD 1500S30

PROPERTY	IMPERIAL VALUE	METRIC VALUE	TEST METHOD	
Color	Light Pink	Light Pink	Visual	
Reinforcement Carrier	Fiberglass	Fiberglass	ASTM D374	
Thickness (in.) / (mm)	0.020 to 0.250	0.508 to 6.350	ASTM D374	
Inherent Surface Tack (1-sided)	2	2	—	
Density (Bulk Rubber) (g/cc)	1.8	1.8	ASTM D792	
Heat Capacity (J/g-K)	1.0	1.0	ASTM E1269	
Hardness (Bulk Rubber) (Shore 00) <sup>(1)</sup>	30	30	ASTM D2240	
Young's Modulus (psi) / (kPa) <sup>(2)</sup>	16	110	ASTM D575	
Continuous Use Temp. (°F) / (°C)	-76 to 392	-60 to 200	—	
<b>ELECTRICAL</b>				
Dielectric Breakdown Voltage (Vac.)	>6,000	>6,000	ASTM D149	
Dielectric Constant (1,000 Hz)	5.0	5.0	ASTM D150	
Volume Resistivity (Ohmmeter)	10 <sup>11</sup>	10 <sup>11</sup>	ASTM D257	
Flame Rating	V-O	V-O	UL 94	
<b>THERMAL</b>				
Thermal Conductivity (W/m-K)	1.3	1.3	ASTM D5470	
<b>THERMAL PERFORMANCE VS. STRAIN</b>				
	Deflection (% strain)	10	20	30
	Thermal Impedance (°C-in.²/W) 0.040 in. <sup>(3)</sup>	1.69	1.41	1.26
<small>1) Thirty-second delay value Shore 00 hardness scale.                  2) Young's Modulus, calculated using 0.01 in./min. step rate of strain with a sample size of 0.79 in.².                  3) The ASTM D5470 test fixture was used. The recorded value includes interfacial thermal resistance. These values are provided for reference only. Actual application performance is directly related to the surface roughness, flatness and pressure applied.</small>				

## Typical Applications:

- Any heat-generating component and a heat sink
- Computers and peripherals
- Telecommunications
- Between any heat-generating semiconductor and a heat sink
- Shielding devices

## Configurations Available:

- Sheet form and die-cut parts

## Building a Part Number

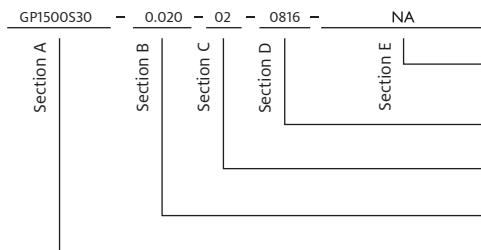

## Standard Options

⚡ *example*

NA = Selected standard option. If not selecting a standard option, insert company name, drawing number, and revision level.

0816 = Standard sheet size 8" x 16", or 00 = custom configuration

02 = Natural tack, both sides

Standard thicknesses available: 0.020", 0.040", 0.060", 0.080", 0.100", 0.125", 0.160", 0.200", 0.250"

GP1500S30 = GAP PAD 1500S30 Material

Note: To build a part number, go to [www.bergquistcompany.com/Part\\_Number\\_Builder.php](http://www.bergquistcompany.com/Part_Number_Builder.php).

# GAP PAD A2000

## High Performance, Thermally Conductive Gap Filling Material

### Features and Benefits

- Thermal conductivity: 2.0 W/m-K
- Fiberglass-reinforced for puncture, shear and tear resistance
- Electrically isolating



GAP PAD A2000 acts as a thermal interface and electrical insulator between electronic components and heat sinks. In the thickness range of 10 to 40 mil, GAP PAD A2000 is supplied with natural tack on both sides, allowing for excellent compliance to the adjacent surfaces of components. The 40 mil material thickness is supplied with lower tack on one side, allowing for burn-in processes and easy rework.

Note: Resultant thickness is defined as the final gap thickness of the application.

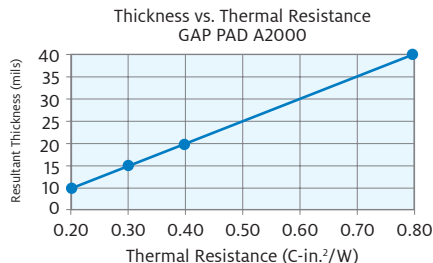

TYPICAL PROPERTIES OF GAP PAD A2000				
PROPERTY	IMPERIAL VALUE	METRIC VALUE	TEST METHOD	
Color	Grey	Grey	Visual	
Reinforcement Carrier	Fiberglass	Fiberglass	—	
Thickness (in.) / (mm)	0.010 to 0.040	0.254 to 1.016	ASTM D374	
Inherent Surface Tack (1-sided)	2	2	—	
Density (Bulk Rubber) (g/cc)	2.9	2.9	ASTM D792	
Heat Capacity (J/g-K)	1.0	1.0	ASTM E1269	
Hardness (Bulk Rubber) (Shore 00) <sup>(1)</sup>	80	80	ASTM D2240	
Young's Modulus (psi) / (kPa) <sup>(2)</sup>	55	379	ASTM D575	
Continuous Use Temp. (°F) / (°C)	-76 to 392	-60 to 200	—	
<b>ELECTRICAL</b>				
Dielectric Breakdown Voltage (Vac.)	4,000	4,000	ASTM D149	
Dielectric Constant (1,000 Hz)	6.0	6.0	ASTM D150	
Volume Resistivity (Ohmmeter)	10 <sup>11</sup>	10 <sup>11</sup>	ASTM D257	
Flame Rating	V-O	V-O	UL 94	
<b>THERMAL</b>				
Thermal Conductivity (W/m-K)	2.0	2.0	ASTM D5470	
<b>THERMAL PERFORMANCE VS. STRAIN</b>				
	Deflection (% strain)	10	20	30
	Thermal Impedance (°C-in. <sup>2</sup> /W) 0.040 in. <sup>(3)</sup>	1.04	1.00	0.95

1) Thirty-second delay value Shore 00 hardness scale.  
 2) Young's Modulus, calculated using 0.01 in./min. step rate of strain with a sample size of 0.79 in.<sup>2</sup>.  
 3) The ASTM D5470 test fixture was used. The recorded value includes interfacial thermal resistance. These values are provided for reference only. Actual application performance is directly related to the surface roughness, flatness and pressure applied.

### Typical Applications Include:

- Computer and peripherals; between CPU and heat spreader
- Telecommunications
- Heat pipe assemblies
- Memory modules
- CDROM / DVD cooling
- Areas where heat needs to be transferred to a frame chassis or other type of heat spreader
- DDR SDRAM memory modules

### Configurations Available:

- Sheet form, die-cut parts and roll form (converted or unconverted)

### Building a Part Number

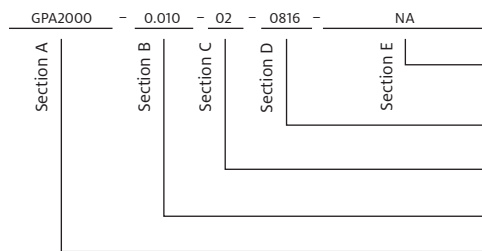

### Standard Options

◀ example  
 NA = Selected standard option. If not selecting a standard option, insert company name, drawing number, and revision level.  
 0816 = Standard sheet size 8" x 16", or 00 = custom configuration  
 02 = Natural tack, both sides  
 Standard thicknesses available: 0.010", 0.015", 0.020", 0.040"  
 GPA2000 = GAP PAD A2000 Material

Note: To build a part number, go to [www.bergquistcompany.com/Part\\_Number\\_Builder.php](http://www.bergquistcompany.com/Part_Number_Builder.php).

# GAP PAD 2000S40

## Highly Conformable, Thermally Conductive, Reinforced “S-Class” Gap Filling Material

### Features and Benefits

- Thermal conductivity: 2.0 W/m-K
- Low “S-Class” thermal resistance at very low pressures
- Highly conformable, low hardness
- Designed for low-stress applications
- Fiberglass-reinforced for puncture, shear and tear resistance

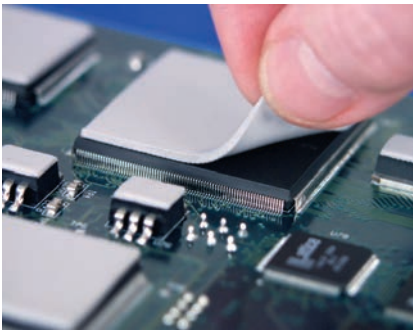

GAP PAD 2000S40 is recommended for low-stress applications that require a mid-to high-thermally conductive interface material. The highly conformable nature of the material allows the pad to fill in air voids and air gaps between PC boards and heat sinks or metal chassis with stepped topography, rough surfaces and high stack-up tolerances.

GAP PAD 2000S40 is offered with inherent natural tack on both sides of the material allowing for stick-in-place characteristics during application assembly. The material is supplied with protective liners on both sides. The top side has reduced tack for ease of handling.

Note: Resultant thickness is defined as the final gap thickness of the application.

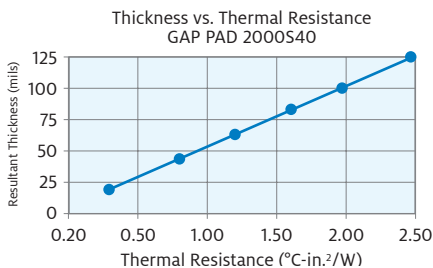

TYPICAL PROPERTIES OF GAP PAD 2000S40				
PROPERTY	IMPERIAL VALUE	METRIC VALUE	TEST METHOD	
Color	Grey	Grey	Visual	
Reinforcement Carrier	Fiberglass	Fiberglass	—	
Thickness (in.) / (mm)	0.020 to 0.125	0.508 to 3.175	ASTM D374	
Inherent Surface Tack (1-sided)	2	2	—	
Density (Bulk Rubber) (g/cc)	2.9	2.9	ASTM D792	
Heat Capacity (J/g-K)	0.6	0.6	ASTM E1269	
Hardness (Bulk Rubber) (Shore 00) <sup>(1)</sup>	30	30	ASTM D2240	
Young's Modulus (psi) / (kPa) <sup>(2)</sup>	45	310	ASTM D575	
Continuous Use Temp. (°F) / (°C)	-76 to 392	-60 to 200	—	
<b>ELECTRICAL</b>				
Dielectric Breakdown Voltage (Vac.)	>5,000	>5,000	ASTM D149	
Dielectric Constant (1,000 Hz)	6.0	6.0	ASTM D150	
Volume Resistivity (Ohmmeter)	10 <sup>11</sup>	10 <sup>11</sup>	ASTM D257	
Flame Rating	V-O	V-O	UL 94	
<b>THERMAL</b>				
Thermal Conductivity (W/m-K)	2.0	2.0	ASTM D5470	
<b>THERMAL PERFORMANCE VS. STRAIN</b>				
	Deflection (% strain)	10	20	30
	Thermal Impedance (°C-in.²/W) 0.040 in. <sup>(3)</sup>	0.97	0.89	0.80
<small>1) Thirty-second delay value Shore 00 hardness scale.                  2) Young's Modulus, calculated using 0.01 in./min. step rate of strain with a sample size of 0.79 in.².                  3) The ASTM D5470 test fixture was used. The recorded value includes interfacial thermal resistance. These values are provided for reference only. Actual application performance is directly related to the surface roughness, flatness and pressure applied.</small>				

### Typical Applications Include:

- Power electronics DC/DC; 1/4, 1/2, full bricks, etc.
- Mass storage devices
- Graphics card/processor/ASIC
- Wireline/wireless communications hardware
- Automotive engine/transmission controls

### Configurations Available:

- Sheet form and die-cut parts

### Building a Part Number

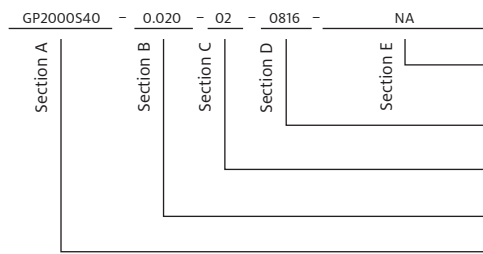

### Standard Options

◀ example

NA = Selected standard option. If not selecting a standard option, insert company name, drawing number, and revision level.

0816 = Standard sheet size 8" x 16", or

00 = custom configuration

02 = Natural tack, both sides

Standard thicknesses available: 0.020", 0.040", 0.060", 0.080", 0.100", 0.125"

GP2000S40 = GAP PAD 2000S40 Material

Note: To build a part number, go to [www.bergquistcompany.com/Part\\_Number\\_Builder.php](http://www.bergquistcompany.com/Part_Number_Builder.php).

# GAP PAD 2200SF

## Thermally Conductive, Silicone-Free Gap Filling Material

### Features and Benefits

- Thermal conductivity: 2.0 W/m-K
- Silicone-free formulation
- Medium compliance with easy handling
- Electrically isolating



GAP PAD 2200SF is a thermally conductive, electrically isolating, silicone-free polymer specially designed for silicone-sensitive applications. The material is ideal for applications with uneven topologies and high stack-up tolerances. GAP PAD 2200SF is reinforced for easy material handling and added durability during assembly. The material is available with a protective liner on both sides. GAP PAD 2200SF is supplied with reduced tack on one side, allowing for burn-in processes and easy rework.

Note: Resultant thickness is defined as the final gap thickness of the application.

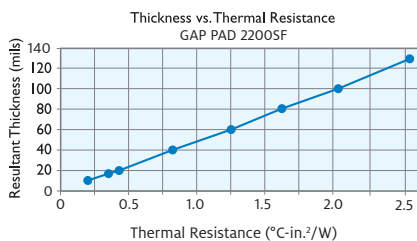

### TYPICAL PROPERTIES OF GAP PAD 2200SF

PROPERTY	IMPERIAL VALUE	METRIC VALUE	TEST METHOD
Color	Green	Green	Visual
Reinforcement Carrier	Fiberglass	Fiberglass	—
Thickness (in.) / (mm)	0.010 to 0.125	0.254 to 3.175	ASTM D374
Inherent Surface Tack (1- or 2-sided)	2	2	—
Density (g/cc)	2.8	2.8	ASTM D792
Heat Capacity (J/g-K)	1.0	1.0	ASTM E1269
Hardness, Bulk Rubber (Shore 00) <sup>(1)</sup>	70	70	ASTM D2240
Young's Modulus (psi) / (kPa) <sup>(2)</sup>	33	228	ASTM D575
Continuous Use Temp. (°F) / (°C)	-76 to 257	-60 to 125	—
<b>ELECTRICAL</b>			
Dielectric Breakdown Voltage (Vac.)	>5,000	>5,000	ASTM D149
Dielectric Constant (1,000 Hz)	6.0	6.0	ASTM D150
Volume Resistivity (Ohmmeter)	10 <sup>8</sup>	10 <sup>8</sup>	ASTM D257
Flame Rating	V-0	V-0	UL 94
<b>THERMAL</b>			
Thermal Conductivity (W/m-K)	2.0	2.0	ASTM D5470

1) Thirty-second delay value Shore 00 hardness scale.  
2) Young's Modulus, calculated using 0.01 in./min. step rate of strain with a sample size of 0.79 in.<sup>2</sup>. For more information on GAP PAD modulus, refer to BERGQUIST Application Note #116 at our website's Technical Library.

### Typical Applications:

- Digital disk drives
- Proximity near electrical contacts (e.g., DC brush motors, connectors, relays)
- Fiber optics modules

### Configurations Available:

- Sheet form
- Die-cut parts
- Standard sheet size is 8 in. x 16 in.

### Building a Part Number

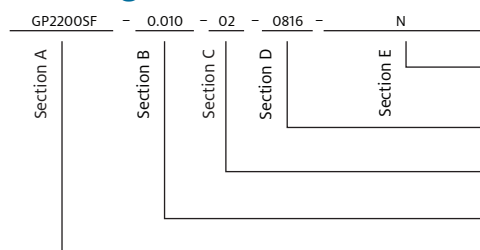

### Standard Options

#### example

NA = Selected standard option. If not selecting a standard option, insert company name, drawing number, and revision level.

0816 = Standard sheet size 8" x 16", or  
00 = custom configuration

02 = Natural tack, both sides

Standard thicknesses available: 0.010", 0.015", 0.020",  
0.040", 0.060", 0.080", 0.100", 0.125"

GP2200SF = GAP PAD 2200SF Material

Note: To build a part number, go to [www.bergquistcompany.com/Part\\_Number\\_Builder.php](http://www.bergquistcompany.com/Part_Number_Builder.php).

# GAP PAD A3000

## Thermally Conductive, Reinforced Gap Filling Material

### Features and Benefits

- Thermal conductivity: 2.6 W/m-K
- Fiberglass-reinforced for puncture, shear and tear resistance
- Reduced tack on one side to aid in application assembly
- Electrically isolating

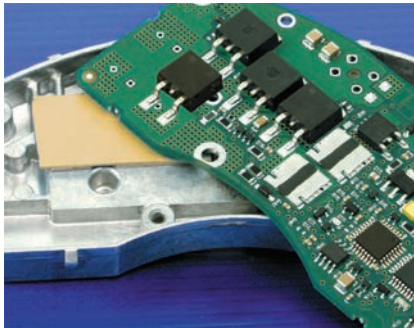

GAP PAD A3000 is a thermally conductive, filled-polymer laminate, supplied on a reinforcing mesh for added electrical isolation, easy material handling and enhanced puncture, shear and tear resistance. GAP PAD A3000 has a reinforcement layer on the dark gold side of the material that assists in burn-in and rework processes while the light gold and soft side of the material allows for added compliance.

Note: Resultant thickness is defined as the final gap thickness of the application.

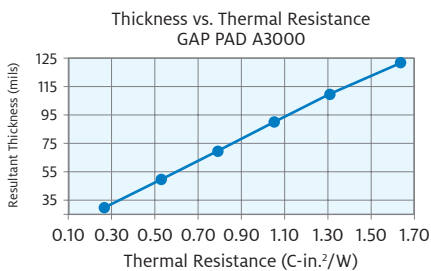

### TYPICAL PROPERTIES OF GAP PAD A3000

PROPERTY	IMPERIAL VALUE	METRIC VALUE	TEST METHOD
Color	Gold	Gold	Visual
Reinforcement Carrier	Fiberglass	Fiberglass	—
Thickness (in.) / (mm)	0.015 to 0.125	0.381 to 3.175	ASTM D374
Inherent Surface Tack (1-sided)	1	1	—
Density (Bulk Rubber) (g/cc)	3.2	3.2	ASTM D792
Heat Capacity (J/g-K)	1.0	1.0	ASTM E1269
Hardness (Bulk Rubber) (Shore 00) <sup>(1)</sup>	80	80	ASTM D2240
Young's Modulus (psi) / (kPa) <sup>(2)</sup>	50	344	ASTM D575
Continuous Use Temp. (°F) / (°C)	-76 to 392	-60 to 200	—
<b>ELECTRICAL</b>			
Dielectric Breakdown Voltage (Vac.)	>5,000	>5,000	ASTM D149
Dielectric Constant (1,000 Hz)	7.0	7.0	ASTM D150
Volume Resistivity (Ohmmeter)	10 <sup>10</sup>	10 <sup>10</sup>	ASTM D257
Flame Rating	V-O	V-O	UL 94
<b>THERMAL</b>			
Thermal Conductivity (W/m-K)	2.6	2.6	ASTM D5470
<b>THERMAL PERFORMANCE VS. STRAIN</b>			
	Deflection (% strain)		
	10	20	30
Thermal Impedance (°C-in.²/W) 0.040 in. <sup>(3)</sup>	0.78	0.73	0.68

1) Thirty-second delay value Shore 00 hardness scale.  
 2) Young's Modulus, calculated using 0.01 in./min. step rate of strain with a sample size of 0.79 in.<sup>2</sup>.  
 3) The ASTM D5470 test fixture was used. The recorded value includes interfacial thermal resistance. These values are provided for reference only. Actual application performance is directly related to the surface roughness, flatness and pressure applied.

### Typical Applications Include:

- Computer and peripherals
- Heat pipe assemblies
- CDROM / DVD cooling
- Area where heat needs to be transferred to a frame, chassis or other type of heat spreader
- Telecommunications
- Memory modules
- Between CPU and heat spreader

### Configurations Available:

- Sheet form, die-cut parts and roll form (converted or unconverted)

### Building a Part Number

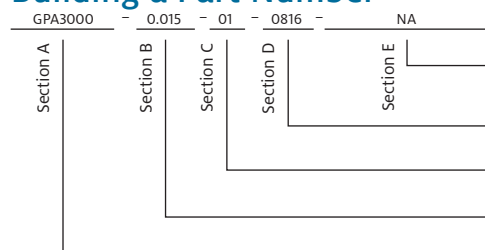

### Standard Options

◀ example

NA = Selected standard option. If not selecting a standard option, insert company name, drawing number, and revision level.

0816 = Standard sheet size 8" x 16", or 00 = custom configuration

01 = Natural tack, one side

Standard thicknesses available: 0.015", 0.020", 0.040", 0.060", 0.080", 0.100", 0.125"

GPA3000 = GAP PAD A3000 Material

Note: To build a part number, go to [www.bergquistcompany.com/Part\\_Number\\_Builder.php](http://www.bergquistcompany.com/Part_Number_Builder.php).



# GAP PAD 3500ULM

## Highly Conformable, Thermally Conductive, Ultra-Low Modulus Material

### Features and Benefits

- Thermal conductivity: 3.5 W/m-K
- Fiberglass-reinforced for shear and tear resistance
- Non-fiberglass option for applications that require an additional reduction in stress

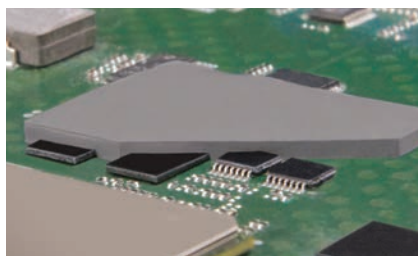

GAP PAD 3500ULM (ultra-low modulus) is an extremely soft gap filling material with a thermal conductivity of 3.5 W/m-K. The material offers exceptional thermal performance at low pressures due to a unique 3.5 W/m-K filler package and ultra-low modulus resin formulation. The enhanced material is well-suited for high performance applications requiring extremely low assembly stress. GAP PAD 3500ULM maintains a conformable nature that allows for excellent interfacing and wet-out characteristics, even to surfaces with high roughness and/or topography.

GAP PAD 3500ULM is offered with and without fiberglass and has higher natural inherent tack on one side of the material, eliminating the need for thermally impeding adhesive layers. The top side has minimal tack for ease of handling. GAP PAD 3500ULM is supplied with protective liners on both sides.

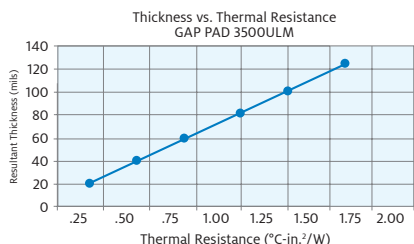

TYPICAL PROPERTIES OF GAP PAD 3500ULM				
PROPERTY	IMPERIAL VALUE	METRIC VALUE	TEST METHOD	
Color	Grey	Grey	Visual	
Reinforcement Carrier	Fiberglass or no fiberglass	Fiberglass or no fiberglass	—	
Thickness (in.) / (mm)	0.020 to 0.125	0.508 to 3.175	ASTM D374	
Inherent Surface Tack	2	2	—	
Density (Bulk Rubber) (g/cc)	3.1	3.1	ASTM D792	
Heat Capacity (J/g-K)	1.0	1.0	ASTM E1269	
Young's Modulus (psi) / (kPa) <sup>(1)(2)</sup>	4	27.5	—	
Continuous Use Temp. (°F) / (°C)	-76 to 392	-60 to 200	—	
<b>ELECTRICAL</b>				
Dielectric Breakdown Voltage (Vac.)	>5,000	>5,000	ASTM D149	
Dielectric Constant (1,000 Hz) <sup>(3)</sup>	6.0	6.0	ASTM D150	
Volume Resistivity (Ohmmeter)	10 <sup>10</sup>	10 <sup>10</sup>	ASTM D257	
Flame Rating	V-O	V-O	UL 94	
<b>THERMAL</b>				
Thermal Conductivity (W/m-K)	3.5	3.5	ASTM D5470	
<b>THERMAL PERFORMANCE VS. STRAIN</b>				
	Deflection (% strain)	10	20	30
	Thermal Impedance (°C-in.²/W) 0.040 in. <sup>(4)</sup>	0.50	0.44	0.39

1) Young's Modulus, calculated using 0.01 in./min. step rate of strain with a sample size of 0.79 in.² after 5 minutes of compression at 10% strain on a 1mm thickness material.  
 2) Thirty-second delay value Shore 000 hardness scale is 70 for 125 mil.  
 3) Minimum value at 20 mil.  
 4) The ASTM D5470 test fixture was used. The recorded value includes interfacial thermal resistance. These values are provided for reference only. Actual application performance is directly related to the surface roughness, flatness and pressure applied.

### Typical Applications Include:

- Consumer electronics
- Telecommunications
- ASICs and DSPs
- PC applications

### Configurations Available:

- Sheet form and die-cut parts

### Building a Part Number

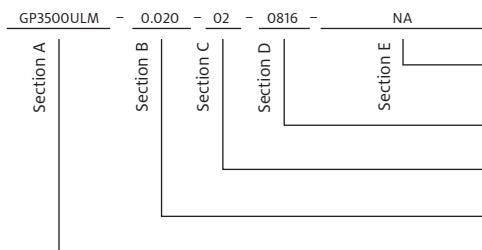

### Standard Options

◀ example

NA = Selected standard option. If not selecting a standard option, insert company name, drawing number, and revision level.

0816 = Standard sheet size 8" x 16", or  
 00 = custom configuration  
 02 = Natural tack, both sides (without fiberglass)  
 12 = Natural tack, both sides (with fiberglass)  
 05 = Non-tack, one side (without fiberglass), 7.87" x 15.75"  
 15 = Non-tack, one side (with fiberglass), 7.87" x 15.75"  
 Standard thicknesses available: 0.020"(fiberglass only), 0.040", 0.060", 0.080", 0.100", 0.125"  
 GP3500ULM = GAP PAD 3500ULM Material without fiberglass  
 GP3500ULM-G = GAP PAD 3500ULM Material with fiberglass  
 (GP3500ULM and GP3500ULM-G are also offered in a NT, non-tack, version)

Note: To build a part number, go to [www.bergquistcompany.com/Part\\_Number\\_Builder.php](http://www.bergquistcompany.com/Part_Number_Builder.php).

# GAP PAD 5000S35

## High Thermal Conductivity Plus “S-Class” Softness and Conformability

### Features and Benefits

- High-thermal conductivity: 5.0 W/m-K
- Highly conformable, “S-Class” softness
- Naturally-inherent tack reduces interfacial thermal resistance
- Conforms to demanding contours and maintains structural integrity with little or no stress applied to fragile component leads
- Fiberglass reinforced for puncture, shear and tear resistance
- Excellent thermal performance at low pressures

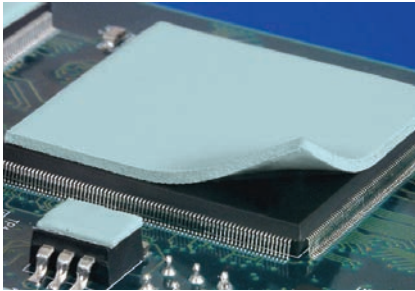

GAP PAD 5000S35 is a fiberglass-reinforced filler and polymer featuring a high thermal conductivity. The material yields extremely soft characteristics while maintaining elasticity and conformability. The fiberglass reinforcement provides easy handling and converting, added electrical isolation and tear resistance. The inherent natural tack on both sides assists in application and allows the product to effectively fill air gaps, enhancing the overall thermal performance. The top side has reduced tack for ease of handling. GAP PAD 5000S35 is ideal for high-performance applications at low mounting pressures.

Note: Resultant thickness is defined as the final gap thickness of the application.

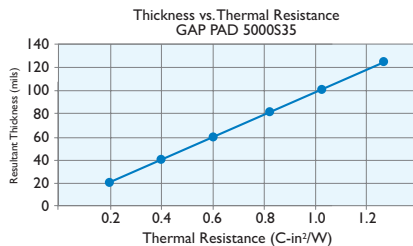

### TYPICAL PROPERTIES OF GAP PAD 5000S35

PROPERTY	IMPERIAL VALUE	METRIC VALUE	TEST METHOD	
Color	Light Green	Light Green	Visual	
Reinforcement Carrier	Fiberglass	Fiberglass	—	
Thickness (in.) / (mm)	0.020 to 0.125	0.508 to 3.175	ASTM D374	
Inherent Surface Tack (1-sided)	2	2	—	
Density (Bulk Rubber) (g/cc)	3.6	3.6	ASTM D792	
Heat Capacity (J/g-K)	1.0	1.0	ASTM E1269	
Hardness (Bulk Rubber) (Shore 00) <sup>(1)</sup>	35	35	ASTM D2240	
Young’s Modulus (psi) / (kPa) <sup>(2)</sup>	17.5	121	ASTM D575	
Continuous Use Temp. (°F) / (°C)	-76 to 392	-60 to 200	—	
<b>ELECTRICAL</b>				
Dielectric Breakdown Voltage (Vac.)	>5,000	>5,000	ASTM D149	
Dielectric Constant (1,000 Hz)	7.5	7.5	ASTM D150	
Volume Resistivity (Ohmmeter)	10 <sup>9</sup>	10 <sup>9</sup>	ASTM D257	
Flame Rating	V-O	V-O	UL 94	
<b>THERMAL</b>				
Thermal Conductivity (W/m-K)	5.0	5.0	ASTM D5470	
<b>THERMAL PERFORMANCE VS. STRAIN</b>				
	Deflection (% strain)	10	20	30
	Thermal Impedance (°C-in. <sup>2</sup> /W) 0.040 in. <sup>(3)</sup>	0.37	0.32	0.29

(1) Thirty second delay value Shore 00 hardness scale.  
 (2) Young’s Modulus, calculated using 0.01 in/min. step rate of strain with a sample size of 0.79 inch.<sup>2</sup>  
 (3) The ASTM D5470 test fixture was used. The recorded value includes interfacial thermal resistance. These values are provided for reference only. Actual application performance is directly related to the surface roughness, flatness and pressure applied.

### Typical Applications Include:

- Voltage Regulator Modules (VRMs) and POLs
- CD ROM/DVD ROM
- PC Board to chassis
- ASICs and DSPs
- Memory packages/modules
- Thermally-enhanced BGAs

### Configurations Available:

- Die-cut parts are available in any shape or size, separated or in sheet form

### Building a Part Number

### Standard Options

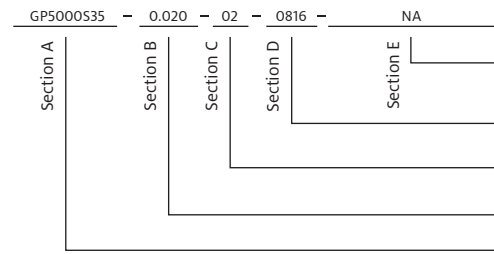

NA = Selected standard option. If not selecting a standard option, insert company name, drawing number, and revision level.

0816 = Standard sheet size 8" x 16", or  
 00 = custom configuration  
 02 = Natural tack, one side  
 03 = Non-tack, one side (fiberglass side), 7.87" x 15.75"  
 05 = Non-tack, one side (upcoat side), 7.87" x 15.75"

Standard thicknesses available: 0.020", 0.040", 0.060", 0.080", 0.100", 0.125"

GP5000S35 = GAP PAD 5000S35 Material  
 GP5000S35 NT = GAP PAD 5000S35 Non-tack Material

Note: To build a part number, go to [www.bergquistcompany.com/Part\\_Number\\_Builder.php](http://www.bergquistcompany.com/Part_Number_Builder.php).

# GAP PAD EMI 1.0

## Thermally Conductive, Conformable EMI Absorbing Material

### Features and Benefits

- Thermal conductivity: 1.0 W/m-K
- Electromagnetic Interference (EMI) absorbing
- Highly conformable, low hardness
- Fiberglass reinforced for puncture, shear and tear resistance
- Electrically isolating



GAP PAD EMI 1.0 is a highly conformable, combination gap filling material offering both thermal conductivity performance and Electromagnetic Energy absorption (cavity resonances and/or cross-talk causing Electromagnetic Interference) at frequencies of 1GHz and higher.

The material offers EMI suppression and 1.0 W/m-K thermal conductivity performance with low assembly stress. The soft nature of the material enhances wet-out at the interface resulting in better thermal performance than harder materials with a similar performance rating. GAP PAD EMI 1.0 has an inherent, natural tack on one side of the material eliminating the need for thermally-impeding adhesive layers and allowing improved handling during placement and assembly. The other side is tack-free, again enhancing handling and rework, if required. GAP PAD EMI 1.0 is supplied with a protective liner on the material's tacky side.

### Typical Applications Include:

- Consumer electronics
- ASICs and DSPs
- Telecommunications
- PC applications

### Configurations Available:

- Sheet form and die-cut parts

### TYPICAL PROPERTIES OF GAP PAD EMI 1.0

PROPERTY	IMPERIAL VALUE	METRIC VALUE	TEST METHOD
Color	Black	Black	Visual
Reinforcement Carrier	Fiberglass	Fiberglass	—
Thickness (in.) / (mm)	0.020 to 0.125	0.508 to 3.175	ASTM D374
Inherent Surface Tack (1-sided)	1	1	—
Density (Bulk Rubber) (g/cc)	2.4	2.4	ASTM D792
Heat Capacity (J/g-K)	1.3	1.3	ASTM E1269
Hardness (Bulk Rubber) (Shore 00) <sup>(1)</sup>	5	5	ASTM D2240
Young's Modulus (psi) / (kPa) <sup>(2)</sup>	10	69	ASTM D575
Continuous Use Temp. (°F) / (°C)	-76 to 392	-60 to 200	—
<b>ELECTRICAL</b>			
Dielectric Breakdown Voltage (Vac.)	>1,700	>1,700	ASTM D149
Dielectric Constant (1,000 Hz)	6.0	6.0	ASTM D150
Volume Resistivity (Ohmmeter)	10 <sup>10</sup>	10 <sup>10</sup>	ASTM D257
Flame Rating	V-O	V-O	UL 94
<b>THERMAL</b>			
Thermal Conductivity (W/m-K) <sup>(3)</sup>	1.0	1.0	ASTM D5470
<b>THERMAL PERFORMANCE VS. STRAIN</b>			
	Deflection (% strain)		
	10	20	30
	Thermal Impedance (°C-in. <sup>2</sup> /W) 0.040 in.		
	1.53	1.40	1.25
<b>EMI PERFORMANCE (ASTM D-5568-01 TEST METHOD)</b>			
	Absorption (4)	dB/inch	dB/cm
	@ 2.4 Ghz	-7	-2.8
	@ 5 Ghz	-14	-5.5
<small>(1) Thirty second delay value Shore 00 hardness scale.            (2) Young's Modulus, calculated using 0.01 in/min. step rate of strain with a sample size of 0.79 inch2. Relaxation stress @ 40 mil.            (3) The ASTM D5470 test fixture was used. The recorded value includes interfacial thermal resistance. These values are provided for reference only. Actual application performance is directly related to the surface roughness, flatness and pressure applied.            (4) Based on waveguide testing with 60 mil thickness testing</small>			

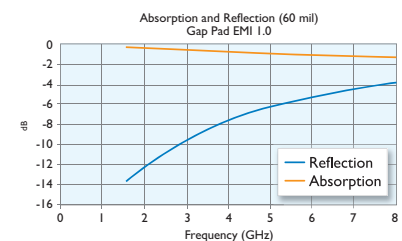
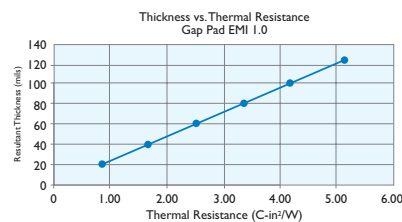

### Building a Part Number

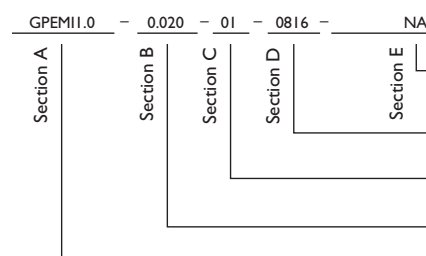

### Standard Options

#### example

NA = Selected standard option. If not selecting a standard option, insert company name, drawing number, and revision level.

0816 = Standard sheet size 8" x 16", or 00 = custom configuration

01 = Natural tack, one side (With Fiberglass)

Standard thicknesses available: 0.020", 0.040", 0.060", 0.080", 0.100", 0.125"

GPEM11.0 = Gap Pad EMI 1.0 Material with fiberglass

Note: To build a part number, go to [www.bergquistcompany.com/Part\\_Number\\_Builder.php](http://www.bergquistcompany.com/Part_Number_Builder.php).

# Gap Filler Liquid Dispensed Materials

## Introduction

Effective thermal management is key to ensuring consistent performance and long-term reliability of many electronic devices. With the wide variety of applications requiring thermal management, the need for alternative thermal material solutions and innovative material placement methods continues to grow. Henkel's family of dispensable liquid polymer materials with unique characteristics is especially designed for ultimate thermal management design and component assembly flexibility.

## Two-Part Gap Fillers

BERGQUIST two-part, cure-in-place materials are dispensed as a liquid onto the target surface. As the components are assembled, the material will wet-out to the adjacent surfaces, filling even the smallest gaps and air voids. Once cured, the material remains a flexible and soft elastomer, designed to assist in relieving coefficient of thermal expansion (CTE) mismatch stresses during thermal cycling. Gap Filler is ideally suited for applications where pads cannot perform adequately, can be used to replace grease or potting compounds, and is currently used in power supply, telecom, digital, and automotive applications.

## Liquid Gap Filler Key Performance Benefits

### Ultra Low Modulus: Minimal Stress During Assembly

Because Gap Filler is dispensed and wet-out in its liquid state, the material will create virtually zero stress on components during the assembly process. Gap Filler can be used to interface even the most fragile and delicate devices.

### Excellent Conformability to Intricate Geometries

Liquid Gap Filler materials are able to conform to intricate topographies, including multi-level surfaces. Due to its increased mobility prior to cure, Gap Filler can fill small air voids, crevices, and holes, reducing overall thermal resistance to the heat generating device.

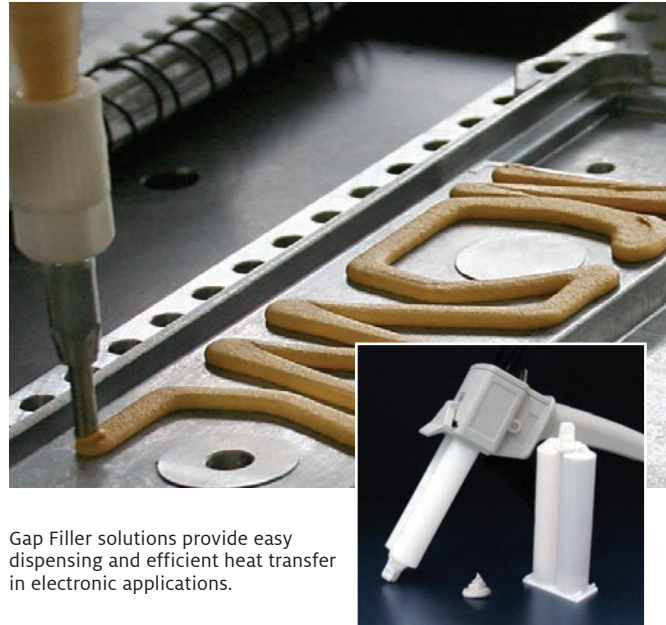
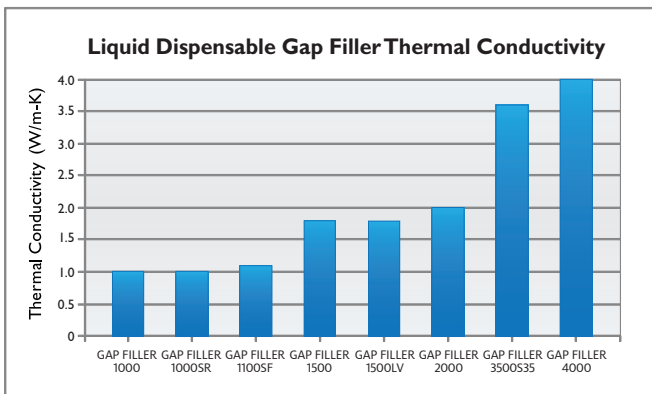

Gap Filler solutions provide easy dispensing and efficient heat transfer in electronic applications.

### Single Solution for Multiple Applications

Unlike pre-cured gap filling materials, the liquid approach offers infinite thickness options and eliminates the need for specific pad thicknesses or die-cut shapes for individual applications.

### Efficient Material Usage

Manual or semiautomatic dispensing tools can be used to apply material directly to the target surface, resulting in effective use of material with minimal waste. Further maximization of material usage can be achieved with implementation of automated dispensing equipment, which allows for precise material placement and reduces the application time of the material.

### Customizable Flow Characteristics

Although Gap Fillers are designed to flow easily under minimal pressure, they are thixotropic in nature which helps the material remain in place after dispensing and prior to cure. BERGQUIST Gap Filler offerings include a range of rheological characteristics and can be tailored to meet customer-specific flow requirements from self-leveling to highly thixotropic materials that maintain their form as dispensed.

## Frequently Asked Questions

### Q: How is viscosity measured?

**A:** Due to the thixotropic characteristics of most Gap Fillers, special consideration should be given to the test method(s) used to determine viscosity of these materials. Because the material viscosity is dependent on shear rate, different measurement equipment testing under varying shear rates will produce varied viscosity readings. When comparing apparent viscosities of multiple materials, it is important to ensure that the data was generated using the same test method and test conditions (therefore the same shear rate). Test methods and conditions for BERGQUIST products are noted in the individual Technical Data Sheets.

### Q: How are pot life and cure time defined?

**A:** Two-part Gap Filler systems begin curing once the two components are mixed together. Henkel defines the pot life (working life) of a two-part system as the time for the viscosity to double after parts A and B are mixed. Henkel defines the cure time of a two-part material as the time to reach 90 percent cure after mixing. Two-part Gap Fillers will cure at room temperature (25°C), or cure time can be accelerated with exposure to elevated temperatures.

### Q: Can I use my Gap Filler after the shelf life has expired?

**A:** Henkel does not advocate using Gap Filler beyond the recommended shelf life and is unable to recertify material that has expired. In order to ensure timely use of product, Henkel recommends a first-in-first-out (FIFO) inventory system.

### Q: How should I store my Gap Filler?

**A:** Unless otherwise indicated on Technical Data Sheets, two-part Gap Fillers should be stored in the original sealed container in a climate-controlled environment at or below 25°C and 50% relative humidity. If stored at reduced temperatures, materials should be placed at room temperature and allowed to stabilize prior to use. Unless otherwise noted, all cartridges and tubes should be stored in Henkel-defined packaging with the nozzle end down.

### Q: Do temperature excursions above 25°C affect the shelf life?

**A:** Short periods of time above the recommended storage temperature, such as during shipping, have not been shown to affect the material characteristics.

### Q: Does Gap Filler have adhesive characteristics?

**A:** Although Gap Fillers are not designed as structural adhesives, when cured, they have a low level of natural tack, which will allow the material to adhere mildly to adjacent components. This aids in keeping the material in the interface throughout repeated temperature cycling and eliminates pump-out from the interface.

### Q: Is Gap Filler reworkable?

**A:** In many cases, Gap Filler can be reworked. The ease of rework is highly dependent on the topography of the application as well as the coverage area.

### Q: What container sizes are available for Gap Fillers?

**A:** Two-part materials are available in several standard dual cartridge sizes including 50 cc (25 cc each of parts A and B) and 400 cc (200 cc each of parts A and B). Gap Fillers are also available in kits of 1200 cc (two stand-alone 600 cc containers, one of each part) and 10-gallon (two 5-gallon pails, one of each part) sizes for higher volume production. Other special and custom container sizes are available upon request.

### Q: How do I mix the two-part Gap Fillers?

**A:** Disposable plastic static mixing nozzles are used to mix parts A and B together at the desired ratio. Static mixers can be attached to the ends of cartridges or mounted on automated dispensing equipment. They are reliable, accurate and inexpensive to replace after extended down times. Unless otherwise indicated, mixing nozzles with a minimum of 21 mixing elements are recommended to achieve proper mixing.

### Q: What is the tolerance on the mix ratio?

**A:** Two-part materials should be mixed to the stated mix ratio by volume within a +/-5% tolerance to ensure proper material characteristics. If light-colored streaks or marbling are present in the material, there has been inadequate mixing. Henkel recommends purging newly tapped containers through the static mixer until a uniform color is achieved. In order to ensure consistent material characteristics and performance, BERGQUIST two-part systems are to be used with matching part A and B lot numbers.

### Q: What options are available for dispensing material onto my application?

**A:** Henkel can provide manual or pneumatic applicator guns for product supplied in dual cartridge form. Gap Filler supplied in high volume container kits can be dispensed via automated dispensing equipment for high-speed in-line manufacturing. Henkel and our other experienced automated dispensing equipment partners can further assist our customers in creating an optimized dispensing process. For information regarding dispensing equipment, contact your local Henkel representative. For some materials, screen or stencil application may be an option and should be evaluated on a case by case basis.

### Q: Should I be concerned about Gap Filler compatibility with other materials in my application?

**A:** Although not common, it is possible to encounter materials that can affect the cure of two-part Gap Fillers. A list of general categories of compounds that may inhibit the rate of cure or poison the curing catalyst in Gap Filler products is available to help assist with material compatibility evaluation. Please contact your local Henkel representative for more details.



## Gap Filler 1000 (Two-Part)

### Thermally Conductive, Liquid Gap Filling Material

#### Features and Benefits

- Thermal conductivity: 1.0 W/m-K
- Ultra-conforming, designed for fragile and low-stress applications
- Ambient and accelerated cure schedules
- 100% solids – no cure by-products
- Excellent low and high temperature mechanical and chemical stability



Gap Filler 1000 is a thermally conductive, liquid gap filling material. It is supplied as a two-component, room or elevated temperature curing system. The material is formulated to provide a balance of cured material properties highlighted by a low modulus and good compression set (memory). The result is a soft, thermally conductive, form-in-place elastomer ideal for coupling “hot” electronic components mounted on PC boards with an adjacent metal case or heat sink. Before cure, Gap Filler 1000 flows under pressure like a grease. After cure, it does not pump from the interface as a result of thermal cycling. Unlike thermal grease, the cured product is dry to the touch. Unlike cured gap filling materials, the liquid approach offers infinite thickness with little or no stress during displacement and eliminates the need for specific pad thickness and die-cut shapes for individual applications. Gap Filler 1000 is intended for use in thermal interface applications when a strong structural bond is not required.

#### TYPICAL PROPERTIES OF GAP FILLER 1000

PROPERTY	IMPERIAL VALUE	METRIC VALUE	TEST METHOD
Color / Part A	Grey	Grey	Visual
Color / Part B	White	White	Visual
Viscosity as Mixed (cPs) <sup>(1)</sup>	100,000	100,000	ASTM D2196
Density (g/cc)	1.6	1.6	ASTM D792
Mix Ratio	1:1	1:1	—
Shelf Life @ 25°C (months)	6	6	—
<b>PROPERTY AS CURED</b>			
Color	Grey	Grey	Visual
Hardness (Shore 00) <sup>(2)</sup>	30	30	ASTM D2240
Heat Capacity (J/g-K)	1.0	1.0	ASTM E1269
Continuous Use Temp. (°F) / (°C)	-76 to 347	-60 to 175	—
<b>ELECTRICAL AS CURED</b>			
Dielectric Strength (V/mil)	500	500	ASTM D149
Dielectric Constant (1,000 Hz)	5.0	5.0	ASTM D150
Volume Resistivity (Ohmmeter)	10 <sup>11</sup>	10 <sup>11</sup>	ASTM D257
Flame Rating	V-O	V-O	UL 94
<b>THERMAL AS CURED</b>			
Thermal Conductivity (W/m-K)	1.0	1.0	ASTM D5470
<b>CURE SCHEDULE</b>			
Pot Life @ 25°C (mins.) <sup>(3)</sup>	15	15	—
Cure @ 25°C (mins.) <sup>(4)</sup>	60 - 120	60 - 120	—
Cure @ 100°C (mins.) <sup>(4)</sup>	5	5	—

1) Brookfield RV, Heli-Path, Spindle TF @ 20 rpm, 25°C.  
 2) Thirty-second delay value Shore 00 hardness scale.  
 3) Time for viscosity to double.  
 4) Cure schedule (rheometer - time to read 90% cure)

#### Typical Applications Include:

- Automotive electronics
- Computer and peripherals
- Between any heat-generating semiconductor and a heat sink
- Telecommunications
- Thermally conductive vibration dampening

#### Configurations Available:

- Supplied in cartridge and kit form

#### Building a Part Number

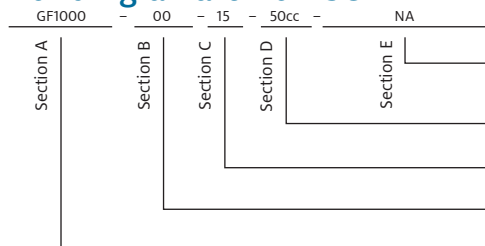

#### Standard Options

◀ example

NA = Selected standard option. If not selecting a standard option, insert company name, drawing number, and revision level.

Cartridges: 50cc = 50.0cc, 400cc = 400.0cc  
 Kits: 1200cc = 1200.0cc, or 10G = 10 gallon

Pot Life: 15 = 15 minutes

00 = No spacer beads  
 07 = 0.007" spacer beads

GF1000 = GAP FILLER 1000 Material

Note: To build a part number, go to [www.bergquistcompany.com/Part\\_Number\\_Builder.php](http://www.bergquistcompany.com/Part_Number_Builder.php).



# Gap Filler 1000SR (Two-Part)

## Thermally Conductive, Liquid Gap Filler Material

### Features and Benefits

- Thermal conductivity: 1.0 W/m-K
- Excellent slump resistance (stays in place)
- Ultra-conforming, with excellent wet-out for low stress interface applications
- 100% solids – no cure by-products
- Excellent low and high temperature mechanical and chemical stability



Gap Filler 1000SR is a two-part, thermally conductive, liquid gap filling material that features exceptional slump resistance. The mixed system will cure at room temperature and can be accelerated with the addition of heat.

Unlike cured thermal pad materials, a liquid approach offers infinite thickness variations with little or no stress to sensitive components during assembly. As cured, Gap Filler 1000SR provides a soft, thermally conductive, form-in-place elastomer that is ideal for fragile assemblies or for filling unique and intricate air voids and gaps.

Gap Filler 1000SR exhibits low level natural tack characteristics and is intended for use in applications where a strong structural bond is not required.

### TYPICAL PROPERTIES OF GAP FILLER 1000SR

PROPERTY	IMPERIAL VALUE	METRIC VALUE	TEST METHOD
Color / Part A	Violet	Violet	Visual
Color / Part B	White	White	Visual
Viscosity, High Shear (Pa-s) <sup>(1)</sup>	20	20	ASTM D5099
Density (g/cc)	2.0	2.0	ASTM D792
Mix Ratio	1:1	1:1	—
Shelf Life @ 25°C (months)	6	6	—
<b>PROPERTY AS CURED</b>			
Color	Violet	Violet	Visual
Hardness (Shore 00) <sup>(2)</sup>	75	75	ASTM D2240
Heat Capacity (J/g-K)	1.0	1.0	ASTM D1269
Continuous Use Temp. (°F) / (°C)	-76 to 347	-60 to 175	—
<b>ELECTRICAL AS CURED</b>			
Dielectric Strength (V/mil)	500	500	ASTM D149
Dielectric Constant (1,000 Hz)	5.1	5.1	ASTM D150
Volume Resistivity (Ohmmeter)	10 <sup>11</sup>	10 <sup>11</sup>	ASTM D257
Flame Rating	V-O	V-O	UL 94
<b>THERMAL AS CURED</b>			
Thermal Conductivity (W/m-K)	1.0	1.0	ASTM D5470
<b>CURE SCHEDULE</b>			
Pot Life @ 25°C (mins.) <sup>(3)</sup>	60	60	—
Cure @ 25°C (hrs.) <sup>(4)</sup>	20	20	—
Cure @ 100°C (mins.) <sup>(4)</sup>	10	10	—

1) Capillary Viscosity, Initial, 4,500 sec-1. Part A and B measured separately.  
 2) Thirty-second delay value Shore 00 hardness scale.  
 3) ARES Parallel Plate Rheometer - Working life as liquid, time for modulus to double.  
 4) ARES Parallel Plate Rheometer - Estimated time to reach 90% cure.

### Typical Applications:

- Automotive electronics
- Computer and peripherals
- Between any heat-generating semiconductor and a heat sink
- Telecommunications

### Configurations Available:

- Supplied in cartridge or kit form

### Building a Part Number

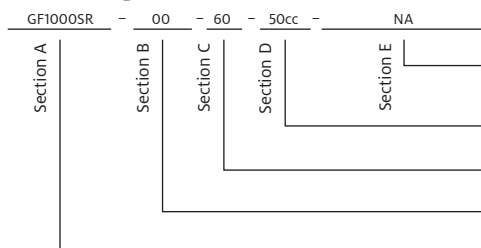

### Standard Options

◀ example

NA = Selected standard option. If not selecting a standard option, insert company name, drawing number, and revision level.

Cartridges: 50cc = 50.0cc, 400cc = 400.0cc  
 Kits: 1200cc = 1200.0cc, or 10G = 10 gallon

Pot Life: 60 = 60 minutes

00 = No spacer beads  
 07 = 0.007" spacer beads

GF1000SR = GAP FILLER 1000SR Material

Note: To build a part number, go to [www.bergquistcompany.com/Part\\_Number\\_Builder.php](http://www.bergquistcompany.com/Part_Number_Builder.php).

# Gap Filler 1100SF (Two-Part)

## Thermally Conductive, Silicone-Free, Liquid Gap Filling Material

### Features and Benefits

- Thermal conductivity: 1.1 W/m-K
- No silicone outgassing or extraction
- Ultra-conforming, designed for fragile and low-stress applications
- Ambient and accelerated cure schedules
- 100% solids – no cure by-products

Gap Filler 1100SF is the thermal solution for silicone-sensitive applications. The material is supplied as a two-part component, curing at room or elevated temperatures. The material exhibits low modulus properties, then cures to a soft, flexible elastomer, helping reduce thermal cycling stresses during operation and virtually eliminating stress during assembly of low-stress applications.

The two components are colored to assist as a mix indicator (1:1 by volume). The mixed system will cure at ambient temperature. Unlike cured thermal pad materials, the liquid approach offers infinite thickness variations with little or no stress during assembly displacement. Gap Filler 1100SF, although exhibiting some natural tack characteristics, is not intended for use in thermal interface applications requiring a mechanical structural bond.

### Application

Gap Filler 1100SF can be mixed and dispensed using dual-tube cartridge packs with static mixers and manual or pneumatic gun or high volume mixing and dispensing equipment (application of heat may be used to reduce viscosity).

#### TEMPERATURE DEPENDENCE OF VISCOSITY

The viscosity of the Gap Filler 1100SF material is temperature dependent. The table below provides the multiplication factor to obtain viscosity at various temperatures. To obtain the viscosity at a given temperature, look up the multiplication factor at that temperature and multiply the corresponding viscosity at 25°C.

Temperature °C	Multiplication Factor	
	Part A	Part B
20	1.43	1.57
25	1.00	1.00
35	0.58	0.50
45	0.39	0.30
50	0.32	0.24

Example - Viscosity of Part A @ 45°:

Viscosity of Part A @ 25°C is 450,000 cPs.

The multiplication factor for Part A @ 45°C is 0.39.

Therefore: (450,000) x (0.39) = 175,500 cPs.

### TYPICAL PROPERTIES OF GAP FILLER 1100SF

PROPERTY	IMPERIAL VALUE	METRIC VALUE	TEST METHOD
Color / Part A	Yellow	Yellow	Visual
Color / Part B	Red	Red	Visual
Viscosity as Mixed (cPs) <sup>(1)</sup>	450,000	450,000	ASTM D2196
Density (g/cc)	2.0	2.0	ASTM D792
Mix Ratio	1:1	1:1	—
Shelf Life @ 25°C (months)	6	6	—
<b>PROPERTY AS CURED</b>			
Color	Orange	Orange	Visual
Hardness (Shore 00) <sup>(2)</sup>	60	60	ASTM D2240
Heat Capacity (J/g-K)	0.9	0.9	ASTM E1269
Continuous Use Temp. (°F) / (°C)	-76 to 257	-60 to 125	—
<b>ELECTRICAL AS CURED</b>			
Dielectric Strength (V/mil)	400	400	ASTM D149
Dielectric Constant (1,000 Hz)	5.0	5.0	ASTM D150
Volume Resistivity (Ohmmeter)	10 <sup>10</sup>	10 <sup>10</sup>	ASTM D257
Flame Rating	V-O	V-O	UL 94
<b>THERMAL AS CURED</b>			
Thermal Conductivity (W/m-K)	1.1	1.1	ASTM D5470
<b>CURE SCHEDULE</b>			
Pot Life @ 25°C <sup>(3)</sup>	240 mins. (4 hrs.)	240 mins. (4 hrs.)	—
Cure @ 25°C (hrs.) <sup>(4)</sup>	24	24	—
Cure @ 100°C (mins.) <sup>(4)</sup>	10	10	—

1) Brookfield RV, Heli-Path, Spindle TF @ 2 rpm, 25°C.  
 2) Thirty-second delay value Shore 00 hardness scale.  
 3) Time for viscosity to double.  
 4) Cure schedule (rheometer - time to read 90% cure).

### Typical Applications Include:

- Silicone-sensitive optic components
- Silicone-sensitive electronics
- Filling various gaps between heat-generating devices to heat sinks and housings
- Mechanical switching relay
- Hard disk assemblies
- Dielectric for bare-leaded devices

### Configurations Available:

- Supplied in cartridge or kit form

### Building a Part Number

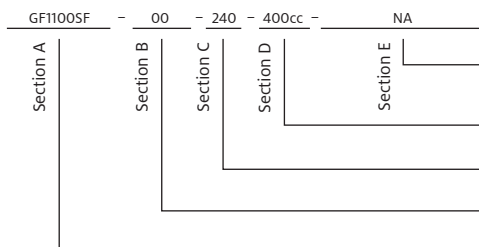

### Standard Options

◀ example

NA = Selected standard option. If not selecting a standard option, insert company name, drawing number, and revision level.

Cartridges: 400cc = 400.0cc  
 Kits: 1200cc = 1200.0cc, or 10G = 10 gallon

Pot Life: 240 = 240 minutes

00 = No spacer beads  
 07 = 0.007" spacer beads

GF1100SF = GAP FILLER 1100SF Material

Note: To build a part number, go to [www.bergquistcompany.com/Part\\_Number\\_Builder.php](http://www.bergquistcompany.com/Part_Number_Builder.php).

## Gap Filler 1400SL (Two-Part)

### Thermally Conductive, Self-Leveling, Liquid Gap Filling Material

#### Features and Benefits

- Thermal conductivity: 1.4 W/m-K
- Self-leveling
- Very soft
- Vibration dampening



Gap Filler 1400SL is a two-part, thermally conductive, silicone based, liquid gap filling material. This material has an extremely low viscosity to enable self-leveling and filling of voids resulting in excellent thermal transfer.

Unlike cured thermal pad materials, a liquid approach offers infinite thickness variations with little or no stress to the sensitive components during assembly. As cured, Gap Filler 1400SL provides a soft, thermally conductive, form-in-place elastomer that is ideal for fragile assemblies and filling unique and intricate gaps.

Gap Filler 1400SL exhibits low level natural tack characteristics and is intended for use in applications where a strong structural bond is not required.

#### Dispensing

Due to its low viscosity nature, Gap Filler 1400SL will settle upon storage. Each container must be thoroughly mixed before combining Part A and Part B via static mixer and dispensing into application.

#### TYPICAL PROPERTIES OF GAP FILLER 1400SL

PROPERTY	IMPERIAL VALUE	METRIC VALUE	TEST METHOD
Color / Part A	Yellow	Yellow	Visual
Color / Part B	White	White	Visual
Viscosity as Mixed (cPs) <sup>(1)</sup>	5,000	5,000	ASTM D2196
Density (g/cc)	2.5	2.5	ASTM D792
Mix Ratio	1:1	1:1	—
Shelf Life @ 25°C (months) <sup>(2)</sup>	6	6	—
<b>PROPERTY AS CURED</b>			
Color	Yellow	Yellow	Visual
Hardness (Shore 00) <sup>(3)</sup>	40	40	ASTM D2240
Heat Capacity (J/g-K)	0.9	0.9	ASTM D1269
Siloxane Content, $\sum D_4 - D_{10}$ (ppm)	40	40	—
Continuous Use Temp. (°F) / (°C)	-76 to 392	-60 to 200	—
<b>ELECTRICAL AS CURED</b>			
Dielectric Strength (V/mil)	250	250	ASTM D149
Dielectric Constant (1000 Hz)	6.0	6.0	ASTM D150
Volume Resistivity (Ohm-meter)	10 <sup>11</sup>	10 <sup>11</sup>	ASTM D257
Flame Rating	V-O	V-O	UL 94
<b>THERMAL AS CURED</b>			
Thermal Conductivity (W/m-K)	1.4	1.4	ASTM D5470
<b>CURE SCHEDULE</b>			
Working Time @ 25°C (min) <sup>(4)</sup>	120	120	—
Cure @ 25°C (hrs.) <sup>(4)</sup>	24	24	—
Cure @ 100°C (mins.) <sup>(4)</sup>	30	30	—

(1) Brookfield Rheometer, Part A and Part B mixed 1:1 ratio.  
 (2) See application note for storage and handling recommendations.  
 (3) Thirty second delay value, Shore 00 scale.  
 (4) Parallel Plate Rheometer, see reactivity application note.

#### Typical Applications Include:

- Automotive electronics
- Telecommunications
- Encapsulating semiconductors and magnetic components with heatsink
- Silicone sensitive applications
- Lighting
- Power Supplies

#### Configurations Available:

- Available for order in 1200cc kits and 7 gallon pail formats

#### Building a Part Number

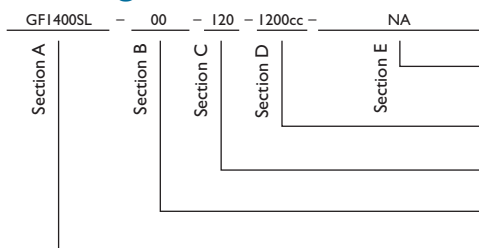

#### Standard Options

◀ example

NA = Selected standard option. If not selecting a standard option, insert company name, drawing number, and revision level.

Kits: 1200cc = 1200.0cc, or 7G = 7 gallon

Working Time: 120 = 120 minutes

00 = No spacer beads

GFI400SL = Gap Filler 1400SL Material

Note: To build a part number, go to [www.bergquistcompany.com/Part\\_Number\\_Builder.php](http://www.bergquistcompany.com/Part_Number_Builder.php).

# Gap Filler 1500 (Two-Part)

## Thermally Conductive Liquid Gap Filling Material

### Features and Benefits

- Thermal conductivity: 1.8 W/mK
- Optimized shear thinning characteristics for ease of dispensing
- Excellent slump resistance (stays in place)
- Ultra-conforming with excellent wet-out for low stress interface applications
- 100% solids – no cure by-products
- Excellent low and high temperature mechanical and chemical stability



Gap Filler 1500 is a two-part, high performance, thermally conductive, liquid gap filling material, which features exceptional slump resistance and high shear thinning characteristics for optimized consistency and control during dispensing. The mixed system will cure at room temperature and can be accelerated with the addition of heat. Unlike cured thermal pad materials, a liquid approach offers infinite thickness variations with little or no stress to the sensitive components during assembly. Gap Filler 1500 exhibits low level natural tack characteristics and is intended for use in applications where a strong structural bond is not required. As cured, Gap Filler 1500 provides a soft, thermally conductive, form-in-place elastomer that is ideal for fragile assemblies and filling unique and intricate air voids and gaps.

### TYPICAL PROPERTIES OF GAP FILLER 1500

PROPERTY	IMPERIAL VALUE	METRIC VALUE	TEST METHOD
Color / Part A	Yellow	Yellow	Visual
Color / Part B	White	White	Visual
Viscosity, High Shear (Pa-s) <sup>(1)</sup>	25	25	ASTM D5099
Density (g/cc)	2.7	2.7	ASTM D792
Mix Ratio	1:1	1:1	—
Shelf Life @ 25°C (months)	6	6	—
<b>PROPERTY AS CURED</b>			
Color		Yellow	Visual
Hardness (Shore 00) <sup>(2)</sup>	50	50	ASTM D2240
Heat Capacity (J/g-K)	1.0	1.0	ASTM D1269
Continuous Use Temp. (°F) / (°C)	-76 to 392	-60 to 200	—
<b>ELECTRICAL AS CURED</b>			
Dielectric Strength (V/mil)	400	400	ASTM D149
Dielectric Constant (1,000 Hz)	6.4	6.4	ASTM D150
Volume Resistivity (Ohmmeter)	10 <sup>10</sup>	10 <sup>10</sup>	ASTM D257
Flame Rating	V-O	V-O	UL 94
<b>THERMAL AS CURED</b>			
Thermal Conductivity (W/m-K)	1.8	1.8	ASTM D5470
<b>CURE SCHEDULE</b>			
	<b>SCHEDULE 1</b>	<b>SCHEDULE 2</b>	
Pot Life @ 25°C <sup>(3)</sup>	60 mins.	480 mins. (8 hrs.)	—
Cure @ 25°C <sup>(4)</sup>	5 hrs.	3 days	—
Cure @ 100°C <sup>(4)</sup>	10 mins.	30 mins.	—

1) Capillary viscosity, initial, 3000 sec-1. Part A and B measured separately.  
 2) Thirty-second delay value Shore 00 hardness scale.  
 3) Parallel Plate Rheometer - Working life as liquid.  
 4) Parallel Plate Rheometer - Estimated time to reach 90% cure.

### Typical Applications Include:

- Automotive electronics
- Computer and peripherals
- Between any heat generating semiconductor and a heat sink
- Telecommunications

### Configurations Available:

- Supplied in cartridge or kit form
- With or without glass beads

### Building a Part Number

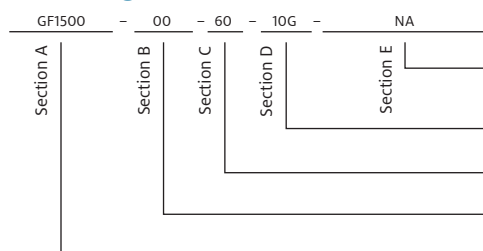

### Standard Options

#### ◀ example

NA = Selected standard option. If not selecting a standard option, insert company name, drawing number, and revision level.

Cartridges: 50cc = 50.0cc, 400cc = 400.0cc  
 Kits: 1200cc = 1200.00cc, 10G = 10 gallon

Pot Life: 60 = 60 min, 480 = 480 min

00 = No spacer beads, 07 = 0.007" spacer beads,  
 10 = 0.010" spacer beads

GF1500 = GAP FILLER 1500 (Two-Part) Material

Note: To build a part number, go to [www.bergquistcompany.com/Part\\_Number\\_Builder.php](http://www.bergquistcompany.com/Part_Number_Builder.php).

## Gap Filler 1500LV (Two-Part)

### Thermally Conductive, Liquid Gap Filler Material

#### Features and Benefits

- Thermal conductivity: 1.8 W/m-K
- Low volatility for silicone-sensitive applications
- Ultra-conforming, with excellent wet-out
- 100% solids — no cure by-products
- Excellent low and high temperature chemical and mechanical stability



Gap Filler 1500LV is a two-part, high performance, thermally conductive, liquid gap filling material. This material offers the high temperature resistance and low modulus of a silicone material with significantly lower levels of silicone outgassing for use in silicone-sensitive applications.

The mixed material will cure at room temperature and can be accelerated with the addition of heat. As cured, Gap Filler 1500LV provides a soft, thermally conductive, form-in-place elastomer that is ideal for fragile assemblies or for filling unique and intricate air voids and gaps.

Liquid dispensed thermal materials offer infinite thickness variations and impart little to no stress on sensitive components during assembly. Gap Filler 1500LV exhibits low level natural tack characteristics and is intended for use in applications where a strong structural bond is not required.

#### TYPICAL PROPERTIES OF GAP FILLER 1500LV

PROPERTY	IMPERIAL VALUE	METRIC VALUE	TEST METHOD
Color / Part A	Yellow	Yellow	Visual
Color / Part B	White	White	Visual
Viscosity, High Shear (Pa-s) <sup>(1)</sup>	20	20	ASTM D5099
Density (g/cc)	2.7	2.7	ASTM D792
Mix Ratio	1:1	1:1	—
Shelf Life @ 25°C (months)	6	6	—
<b>PROPERTY AS CURED</b>			
Color	Yellow	Yellow	Visual
Hardness (Shore 00) <sup>(2)</sup>	80	80	ASTM D2240
Heat Capacity (J/g-K)	1.0	1.0	ASTM D1269
Siloxane Content, SD4-D10 (ppm)	<100	<100	—
Continuous Use Temp. (°F) / (°C)	-76 to 392	-60 to 200	—
<b>ELECTRICAL AS CURED</b>			
Dielectric Strength (V/mil)	400	400	ASTM D149
Dielectric Constant (1,000 Hz)	6.2	6.2	ASTM D150
Volume Resistivity (Ohmmeter)	10 <sup>10</sup>	10 <sup>10</sup>	ASTM D257
Flame Rating	V-O	V-O	UL 94
<b>THERMAL AS CURED</b>			
Thermal Conductivity (W/m-K)	1.8	1.8	ASTM D5470
<b>CURE SCHEDULE</b>			
Working Time @ 25°C <sup>(3)</sup>	120 mins. (2 hrs.)	120 mins. (2 hrs.)	—
Cure @ 25°C (hrs.) <sup>(3)</sup>	8	8	—
Cure @ 100°C (mins.) <sup>(3)</sup>	10	10	—

1) Capillary Viscosity, 3000/sec, Part A and B measured separately.  
 2) Thirty-second delay value Shore 00 hardness scale.  
 3) Parallel plate rheometer, see reactivity application note.

#### Typical Applications:

- Lighting
- Automotive electronics
- Silicone sensitive applications

#### Configurations Available:

- Supplied in cartridge or kit form

#### Building a Part Number

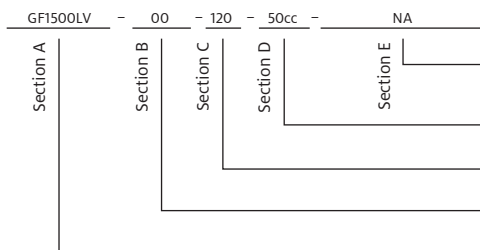

#### Standard Options

##### ◀ example

NA = Selected standard option. If not selecting a standard option, insert company name, drawing number, and revision level.

Cartridges: 50cc = 50.0cc, 400cc = 400.0cc  
 Kits: 1200cc = 1200.0cc, or 10G = 10 gallon

Pot Life: 120 = 120 minutes

00 = No spacer beads

07 = 0.007" spacer beads

10 = 0.010" spacer beads

GF1500LV = GAP FILLER 1500LV Material

Note: To build a part number, go to [www.bergquistcompany.com/Part\\_Number\\_Builder.php](http://www.bergquistcompany.com/Part_Number_Builder.php).

## Gap Filler 2000 (Two-Part)

### Thermally Conductive, Liquid Gap Filling Material

#### Features and Benefits

- Thermal conductivity: 2.0 W/m-K
- Ultra-conforming, designed for fragile and low-stress applications
- Ambient and accelerated cure schedules
- 100% solids – no cure by-products
- Excellent low and high temperature mechanical and chemical stability

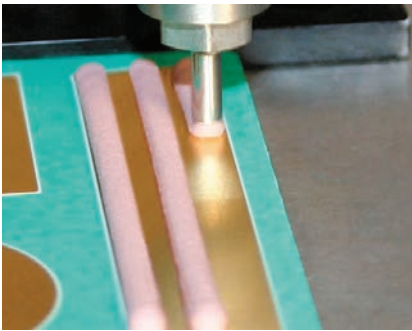

Gap Filler 2000 is a high performance, thermally conductive, liquid gap-filling material supplied as a two-component, room or elevated temperature curing system. The material provides a balance of cured material properties and good compression set (memory). The result is a soft, form-in-place elastomer ideal for coupling “hot” electronic components mounted on PC boards with an adjacent metal case or heat sink. Before cure, it flows under pressure like grease. After cure, it won’t pump from the interface as a result of thermal cycling and is dry to the touch.

Unlike cured gap filling materials, the liquid approach offers infinite thickness with little or no stress during displacement and assembly. It also eliminates the need for specific pad thickness and die-cut shapes for individual applications.

Gap Filler 2000 is intended for use in thermal interface applications when a strong structural bond is not required.

#### TYPICAL PROPERTIES OF GAP FILLER 2000

PROPERTY	IMPERIAL VALUE	METRIC VALUE	TEST METHOD
Color / Part A	Pink	Pink	Visual
Color / Part B	White	White	—
Viscosity as Mixed (cPs) <sup>(1)</sup>	300,000	300,000	ASTM D2196
Density (g/cc)	2.9	2.9	ASTM D792
Mix Ratio	1:1	1:1	—
Shelf Life @ 25°C (months)	6	6	—
<b>PROPERTY AS CURED</b>			
Color	Pink	Pink	Visual
Hardness (Shore 00) <sup>(2)</sup>	70	70	ASTM D2240
Heat Capacity (J/g-K)	1.0	1.0	ASTM D1269
Continuous Use Temp. (°F) / (°C)	-76 to 392	-60 to 200	—
<b>ELECTRICAL AS CURED</b>			
Dielectric Strength (V/mil)	500	500	ASTM D149
Dielectric Constant (1,000 Hz)	7	7	ASTM D150
Volume Resistivity (Ohmmeter)	10 <sup>11</sup>	10 <sup>11</sup>	ASTM D257
Flame Rating	V-O	V-O	UL 94
<b>THERMAL AS CURED</b>			
Thermal Conductivity (W/m-K)	2.0	2.0	ASTM D5470
<b>CURE SCHEDULE</b>			
	<b>SCHEDULE 1</b>	<b>SCHEDULE 2</b>	<b>SCHEDULE 3</b>
Pot Life @ 25°C <sup>(3)</sup>	15 mins.	60 mins.	600 mins. (10 hr)
Cure @ 25°C <sup>(4)</sup>	1-2 hrs.	3-4 hrs.	3 days
Cure @ 100°C <sup>(4)</sup>	5 mins.	15 mins.	1 hr

1) Brookfield RV, Heli-Path, Spindle TF @ 20 rpm, 25°C.  
 2) Thirty-second delay value Shore 00 hardness scale.  
 3) Time for viscosity to double.  
 4) Cure schedule (rheometer - time to read 90% cure).

#### Typical Applications Include:

- Automotive electronics
- Computer and peripherals
- Between any heat-generating semiconductor and a heat sink
- Telecommunications
- Thermally conductive vibration dampening

#### Configurations Available:

- Supplied in cartridge or kit form

#### Building a Part Number

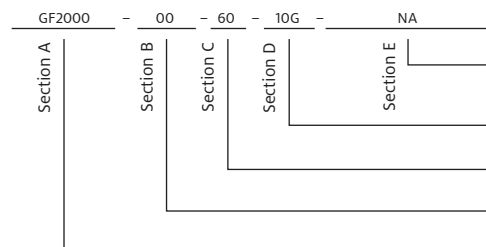

#### Standard Options

◀ example

NA = Selected standard option. If not selecting a standard option, insert company name, drawing number, and revision level.

Cartridges: 50cc = 50.0cc, 400cc = 400.0cc  
 Kits: 1200cc = 1200.0cc, or 10G = 10 gallon

Pot Life: 15 = 15 minutes, 60 = 60 minutes  
 600 = 600 minutes

00 = No spacer beads  
 07 = 0.007" spacer beads

GF2000 = GAP FILLER 2000 Material

Note: To build a part number, go to [www.bergquistcompany.com/Part\\_Number\\_Builder.php](http://www.bergquistcompany.com/Part_Number_Builder.php).



# Gap Filler 3500LV (Two-Part)

## Thermally Conductive, Liquid Gap Filler Material

### Features and Benefits

- Thermal conductivity: 3.5 W/m-K
- Low volatility for outgassing sensitive applications
- Ultra-conforming with excellent wet-out for low stress interfaces on applications
- 100% solids - no cure by-products



Gap Filler 3500LV is a two-part, high thermal conductivity, liquid gap filling material. This material offers the mechanical property benefits of a silicone material with the additional feature of low outgassing.

The mixed material will cure at room temperature or can be accelerated with the addition of heat.

The liquid approach offers infinite thickness variations with little to no stress to sensitive components during assembly. As cured, Gap Filler 3500LV provides a soft, form-in-place elastomer that is ideal for fragile assemblies or for filling intricate air voids.

### TYPICAL PROPERTIES OF GAP FILLER 3500LV

PROPERTY	IMPERIAL VALUE	METRIC VALUE	TEST METHOD
Color / Part A	Blue	Blue	Visual
Color / Part B	White	White	Visual
Viscosity, High Shear (Pa·s) <sup>(1)</sup>	45	45	ASTM D5099
Density (g/cc)	3.1	3.1	ASTM D792
Mix Ratio	1:1	1:1	—
Shelf Life @ 25°C (months)	5	5	—
<b>PROPERTY AS CURED</b>			
Color	Lite Blue	Lite Blue	Visual
Hardness (Shore 00) <sup>(2)</sup>	40	40	ASTM D2240
Heat Capacity (J/g-K)	0.8	0.8	ASTM D1269
Siloxane Content, $\sum D_4 - D_{10}$ (ppm)	40	40	—
Continuous Use Temp. (°F) / (°C)	-76 to 392	-60 to 200	—
<b>ELECTRICAL AS CURED</b>			
Dielectric Strength (V/mil)	275	275	ASTM D149
Dielectric Constant (1,000 Hz)	8.0	8.0	ASTM D150
Volume Resistivity (Ohmmeter)	10 <sup>10</sup>	10 <sup>10</sup>	ASTM D257
Flame Rating	V-O	V-O	UL 94
<b>THERMAL AS CURED</b>			
Thermal Conductivity (W/m-K)	3.5	3.5	ASTM D5470
<b>CURE SCHEDULE</b>			
Working Time @ 25°C <sup>(3)</sup>	240 mins. (4 hrs.)	240 mins. (4 hrs.)	—
Cure @ 25°C (hrs.) <sup>(3)</sup>	24	24	—
Cure @ 100°C (mins.) <sup>(3)</sup>	30	30	—

(1) Capillary Viscosity, 1,500/sec., Part A and B measured separately.  
 (2) Thirty-second delay value Shore 00 hardness scale.  
 (3) Parallel plate rheometer, see reactivity application note.

### Typical Applications:

- Lighting
- Automotive in-cabin electronics
- Medical electronics
- Industrial controls
- Optics

### Configurations Available:

- Supplied in cartridge or kit form

### Building a Part Number

GF3500LV - 00 - 240 - 50cc - NA

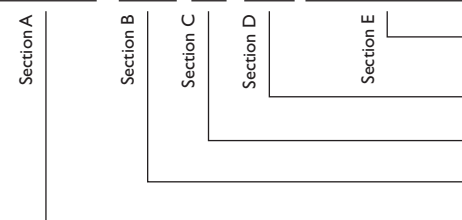

### Standard Options

◀ example

NA = Selected standard option. If not selecting a standard option, insert company name, drawing number, and revision level.

Cartridges: 50cc = 50.0cc, 400cc = 400.0cc  
 Kits: 1200cc = 1200.0cc, or 10G = 10 gallon

Working Time: 240 = 240 minutes

00 = No spacer beads  
 07 = 0.007" spacer beads  
 10 = 0.010" spacer beads

GF3500LV = Gap Filler 3500LV Material

Note: To build a part number, go to [www.bergquistcompany.com/Part\\_Number\\_Builder.php](http://www.bergquistcompany.com/Part_Number_Builder.php).

## Gap Filler 3500S35 (Two-Part)

### Thermally Conductive Liquid Gap Filling Material

#### Features and Benefits

- Thermal conductivity: 3.6 W/m-K
- Thixotropic nature makes it easy to dispense
- Two-part formulation for easy storage
- Ultra-conforming – designed for fragile and low stress applications
- Ambient or accelerated cure schedules

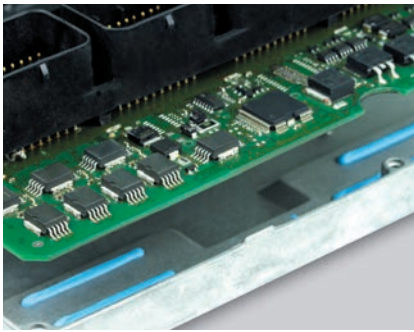

Gap Filler 3500S35 is a two-component, liquid gap-filling material, cured at either room or elevated temperature, featuring ultra-high thermal performance and outstanding softness. Prior to curing, the material maintains good thixotropic characteristics as well as low viscosity. The result is a gel-like liquid material designed to fill air gaps and voids yet flow when acted upon by an external force (e.g., dispensing or assembly process). The material is an excellent solution for interfacing fragile components with high topography and/or stack-up tolerances to a universal heat sink or housing. Once cured, it remains a low modulus elastomer designed to assist in relieving CTE stresses during thermal cycling yet maintain enough modulus to prevent pump-out from the interface. Gap Filler 3500S35 will lightly adhere to surfaces, thus improving surface area contact. Gap Filler 3500S35 is not designed to be a structural adhesive.

#### TYPICAL PROPERTIES OF GAP FILLER 3500S35

PROPERTY	IMPERIAL VALUE	METRIC VALUE	TEST METHOD
Color / Part A	White	White	Visual
Color / Part B	Blue	Blue	Visual
Viscosity as Mixed (cPs) <sup>(1)</sup>	150,000	150,000	ASTM D2196
Density (g/cc)	3.0	3.0	ASTM D792
Mix Ratio	1:1	1:1	—
Shelf Life @ 25°C (months)	5	5	—
<b>PROPERTY AS CURED</b>			
Color	Blue	Blue	Visual
Hardness (Shore 00) <sup>(2)</sup>	35	35	ASTM D2240
Continuous Use Temp. (°F) / (°C)	-76 to 392	-60 to 200	—
<b>ELECTRICAL AS CURED</b>			
Dielectric Strength (V/mil)	275	275	ASTM D149
Dielectric Constant (1,000 Hz)	8.0	8.0	ASTM D150
Volume Resistivity (Ohmmeter)	10 <sup>9</sup>	10 <sup>9</sup>	ASTM D257
Flame Rating	V-0	V-0	UL 94
<b>THERMAL AS CURED</b>			
Thermal Conductivity (W/m-K)	3.6	3.6	ASTM D5470
<b>CURE SCHEDULE</b>			
Pot Life @ 25°C (mins.) <sup>(3)</sup>	60	60	—
Cure @ 25°C (hrs.) <sup>(4)</sup>	15	15	—
Cure @ 100°C (mins.) <sup>(4)</sup>	30	30	—

1) Brookfield RV, Heli-Path, Spindle TF @ 20 rpm, 25°C.  
 2) Thirty-second delay value Shore 00 hardness scale.  
 3) Time for viscosity to double.  
 4) Cure schedule (rheometer - time to read 90% cure).

#### Typical Applications Include:

- Automotive electronics
- Discrete components to housing
- PCBA to housing
- Fiber optic telecommunications equipment

#### Configurations Available:

- Supplied in cartridge or kit form

#### Building a Part Number

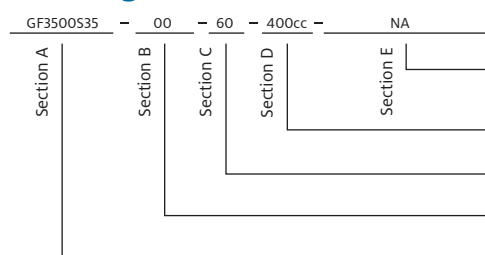

#### Standard Options

##### ◀ example

NA = Selected standard option. If not selecting a standard option, insert company name, drawing number, and revision level.

Cartridges: 50cc = 50.0cc, 400cc = 400.0cc  
 Kits: 1200cc = 1200.0cc, or 6G = 6 gallon

Pot Life: 60 = 60 minutes

00 = No spacer beads  
 07 = 0.007" spacer beads

GP3500S35 = GAP PAD 3500S35 Material

Note: To build a part number, go to [www.bergquistcompany.com/Part\\_Number\\_Builder.php](http://www.bergquistcompany.com/Part_Number_Builder.php).

# Gap Filler 4000 (Two-Part)

## Thermally Conductive, Liquid Gap Filler Material

### Features and Benefits

- Thermal conductivity: 4.0 W/m-K
- Extended working time for manufacturing flexibility
- Ultra-conforming with excellent wet-out
- 100% solids – no cure by-products
- Excellent low and high temperature chemical and mechanical stability



Gap Filler 4000 is a two-part, high performance, thermally conductive, liquid gap-filling material. The mixed material will cure at room temperature and can be accelerated with the addition of heat. Gap Filler 4000 offers an extended working time to allow greater flexibility in the customer’s assembly process.

Liquid dispensed thermal materials offer infinite thickness variations and impart little to no stress on sensitive components during assembly. Gap Filler 4000 exhibits low level natural tack characteristics and is intended for use in applications where a strong structural bond is not required.

As cured, Gap Filler 4000 provides a soft, thermally conductive, form-in-place elastomer that is ideal for fragile assemblies or for filling unique and intricate air voids and gaps.

### TYPICAL PROPERTIES OF GAP FILLER 4000

PROPERTY	IMPERIAL VALUE	METRIC VALUE	TEST METHOD
Color / Part A	Blue	Blue	Visual
Color / Part B	White	White	Visual
Viscosity, High Shear (Pa-s) <sup>(1)</sup>	50	50	ASTM D5099
Density (g/cc)	3.1	3.1	ASTM D792
Mix Ratio	1:1	1:1	—
Shelf Life @ 25°C (months)	5	5	—
<b>PROPERTY AS CURED</b>			
Color	Blue	Blue	Visual
Hardness (Shore 00) <sup>(2)</sup>	75	75	ASTM D2240
Heat Capacity (J/g-K)	0.8	0.8	ASTM D1269
Continuous Use Temp. (°F) / (°C)	-76 to 392	-60 to 200	—
<b>ELECTRICAL AS CURED</b>			
Dielectric Strength (V/mil)	450	450	ASTM D149
Dielectric Constant (1,000 Hz)	7.9	7.9	ASTM D150
Volume Resistivity (Ohmmeter)	10 <sup>10</sup>	10 <sup>10</sup>	ASTM D257
Flame Rating	V-O	V-O	UL 94
<b>THERMAL AS CURED</b>			
Thermal Conductivity (W/m-K)	4.0	4.0	ASTM D5470
<b>CURE SCHEDULE</b>			
Working Time @ 25°C <sup>(3)</sup>	240 mins. (4 hrs.)	240 mins. (4 hrs.)	—
Cure @ 25°C (hrs.) <sup>(3)</sup>	24	24	—
Cure @ 100°C (mins.) <sup>(3)</sup>	30	30	—

<sup>1)</sup> Capillary Viscosity, 1,500/sec., Part A and B measured separately.  
<sup>2)</sup> Thirty-second delay value Shore 00 hardness scale.  
<sup>3)</sup> Parallel plate rheometer, see reactivity application note.

### Typical Applications:

- Automotive electronics
- Computer and peripherals
- Between any heat-generating semiconductor and a heat sink
- Telecommunications

### Configurations Available:

- Supplied in cartridge or kit form

### Building a Part Number

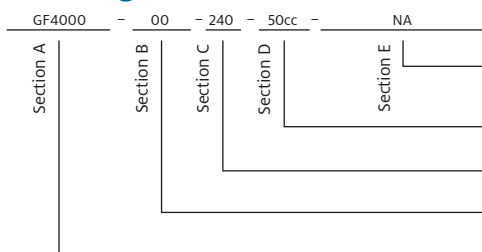

### Standard Options

◀ example

NA = Selected standard option. If not selecting a standard option, insert company name, drawing number, and revision level.

Cartridges: 50cc = 50.0cc, 400cc = 400.0cc  
 Kits: 1200cc = 1200.0cc, or 6G = 6 gallon

Pot Life: 240 = 240 minutes

00 = No spacer beads  
 07 = 0.007" spacer beads  
 10 = 0.010" spacer beads

GF4000 = GAP FILLER 4000 Material

Note: To build a part number, go to [www.bergquistcompany.com/Part\\_Number\\_Builder.php](http://www.bergquistcompany.com/Part_Number_Builder.php).

# Thermal Interface Compounds (One-Part)

## Thermally Conductive Grease Compounds

The BERGQUIST line of thermally conductive thermal interface compounds (TIC) will flow under assembly pressure to wet-out the thermal interface surfaces and produce very low thermal

impedance. TIC products are designed for use between a high-end computer processor and a heat sink or other high watt density applications.

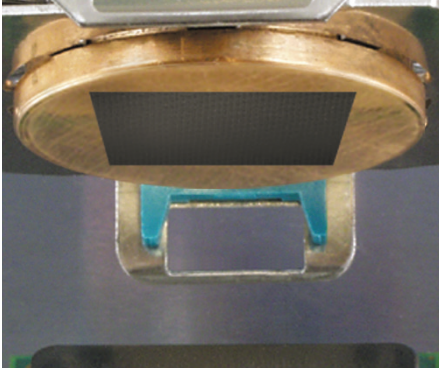

### Features

The TIC portfolio has diverse thermal and electrical characteristics. Key criteria when selecting TIC products include:

- Viscosity
- Volume resistivity
- Thermal conductivity
- Thermal performance
- Filler size

### Benefits

TIC products are ideal for high watt density applications. Primary benefits include:

- Low interfacial resistance
- Low thermal impedance
- Resist dripping
- Ideally suited to screen printing applications
- No post “cure” conditioning required

### Options

TIC products can be obtained with application-specific options such as:

- Containers

### Applications

TICs have a variety of applications such as:

- CPU
- GPU
- IGBT
- High power density applications

## Comparison Data and FAQs

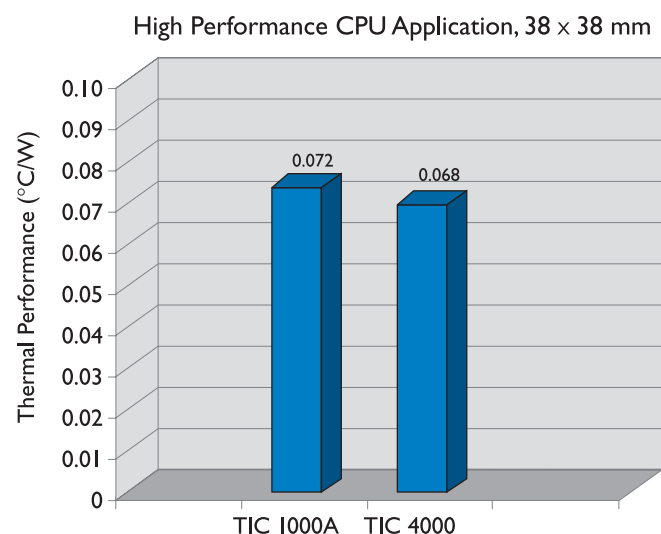

### Q: What is the best fastening method for a TIC interface?

**A:** A constant-pressure fastener is preferred when using TIC for high performance applications. The constant pressure from a clip or spring washer will ensure adequate pressure is being applied with varying bond line thickness.

### Q: How should the TIC be applied?

**A:** Screenprinting the TIC is a fast, low-cost method that delivers a consistent and accurate amount of material on each application. Alternate methods include stenciling, pin transfer and needle dispensing.

### Q: Will the grease stay in the interface?

**A:** All the TIC materials were specifically designed to resist pump-out of the interface, even after many hours of thermal and power cycling.

# TIC 1000A

## High Performance, Value Compound for High-End Computer Processors

### Features and Benefits

- High thermal performance: 0.32°C/W (@ 50 psi)
- Good screenability
- Room temperature storage
- No post “cure” required
- Exceptional value

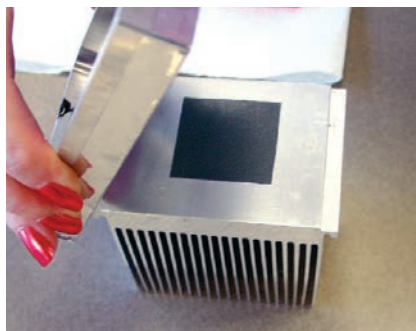

TIC 1000A is a high performance, thermally conductive compound intended for use as a thermal interface material between a high-end computer processor and a heat sink. Other high watt density applications will also benefit from the extremely low thermal impedance of TIC 1000A.

TIC 1000A compound wets-out the thermal interface surfaces and flows to produce the lowest thermal impedance. The compound requires pressure of the assembly to cause flow. The TIC 1000A compound will resist dripping.

For microprocessor applications, traditional screw fastening or spring clamping methods will provide adequate force to optimize the thermal performance of TIC 1000A.

An optimized application would utilize the minimum volume of TIC 1000A material necessary to ensure complete wet-out of both mechanical interfaces.

TYPICAL PROPERTIES OF TIC 1000A						
PROPERTY	IMPERIAL VALUE	METRIC VALUE	TEST METHOD			
Color	Grey	Grey	Visual			
Density (g/cc)	2.1	2.1	ASTM D792			
Continuous Use Temp. (°F) / (°C)	302	150	—			
ELECTRICAL						
Electrical Resistivity (Ohmmeter) <sup>(1)</sup>	N/A	N/A	ASTM D257			
THERMAL						
Thermal Conductivity (W/m-K)	1.5	1.5	ASTM D5470			
THERMAL PERFORMANCE VS. PRESSURE						
	Pressure (psi)	10	25	50	100	200
	TO-220 Thermal Performance (°C/W) <sup>(2)</sup>	0.32	0.32	0.32	0.31	0.28

1) The compound contains an electrically conductive filler surrounded by electrically nonconductive resin.  
2) TO-220 performance data is provided as a reference to compare material thermal performance.

### Assembly – No Post-Screen Cure

TIC 1000A has good screenability. No solvent is used to reduce the viscosity, so no post “cure” conditioning is required.

### Application Cleanliness

1. Pre-clean heat sink and component interface with isopropyl alcohol prior to assembly or repair. Ensure heat sink is dry before applying TIC 1000A.

### Application Methods

1. Dispense and/or screenprint TIC 1000A compound onto the processor or heat sink surface like thermal grease (see a Henkel Representative for application information).
2. Assemble the processor and heat sink with spring clips or constant-pressure fasteners.

### Typical Applications Include:

- High performance CPUs
- High performance GPUs

### Building a Part Number

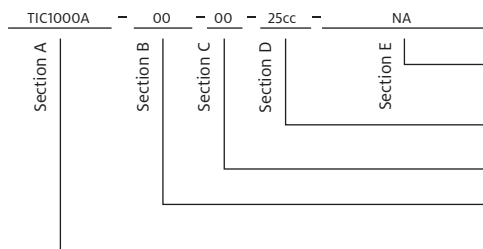

### Standard Options

◀ example  
 NA = Selected standard option. If not selecting a standard option, insert company name, drawing number, and revision level.  
 Containers: 5cc = 5.0cc, 25cc = 25.0cc, 200cc = 200.0cc  
 Cartridge: 600cc = 600.0cc  
 00 = No options  
 00 = No options  
 TIC1000A = Thermal Interface Compound 1000A

Note: To build a part number, go to [www.bergquistcompany.com/Part\\_Number\\_Builder.php](http://www.bergquistcompany.com/Part_Number_Builder.php).

# TIC 4000

## High Performance Thermal Interface Compound for Copper-Based Heat Sinks

### Features and Benefits

- Thermal conductivity: 4.0 W/m-K
- Exceptional thermal performance: 0.19°C/W (@ 50 psi)

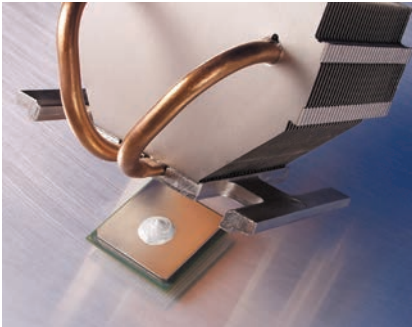

TIC 4000 is a thermally conductive grease compound designed for use as a thermal interface material between a computer processor and a copper-based heat sink. Other high watt density applications will benefit from the extremely low thermal impedance of TIC 4000.

TIC 4000 compound wets-out the thermal interface surfaces and flows to produce low thermal impedance. The compound requires pressure of the assembly to cause flow. TIC 4000 compound will not drip.

For a typical 0.5 in. x 0.5 in. application at 0.005 in. thick, Henkel estimates approximately 0.02 ml (cc) of TIC 4000.

Although Henkel estimates a 0.02 ml (cc) volumetric requirement for a 0.5 in. x 0.5 in. component interface, dispensed at a thickness of 0.005 in., Henkel also recognizes that an optimized application would use the minimum volume of TIC 4000 material necessary to ensure complete wet-out of both mechanical interfaces.

### TYPICAL PROPERTIES OF TIC 4000

PROPERTY	IMPERIAL VALUE	METRIC VALUE	TEST METHOD			
Color	Grey	Grey	Visual			
Density (g/cc)	4.0	4.0	ASTM D792			
Continuous Use Temp. (°F) / (°C)	302	150	—			
<b>ELECTRICAL</b>						
Electrical Resistivity (Ohmmeter) <sup>(1)</sup>	N/A	N/A	ASTM D257			
<b>THERMAL</b>						
Thermal Conductivity (W/m-K)	4.0	4.0	ASTM D5470			
<b>THERMAL PERFORMANCE VS. PRESSURE</b>						
	Pressure (psi)	10	25	50	100	200
	TO-220 Thermal Performance (°C/W) <sup>(2)</sup>	0.21	0.20	0.19	0.19	0.18

1) The compound contains an electrically conductive filler surrounded by electrically nonconductive resin.  
2) TO-220 performance data is provided as a reference to compare material thermal performance.

### Application Methods

1. Pre-clean heat sink and component interface with isopropyl alcohol prior to assembly or repair. Ensure heat sink is dry before applying TIC 4000.
2. Dispense TIC 4000 compound onto the processor or heat sink surface like thermal grease.
3. Assemble the processor and heat sink with clip or constant-pressure fasteners.

### Typical Applications Include:

- High performance computer processors (traditional screw fastening or clamping methods will provide adequate force to optimize the thermal performance of TIC 4000)
- High watt density applications where the lowest thermal resistance interface is required

### Building a Part Number

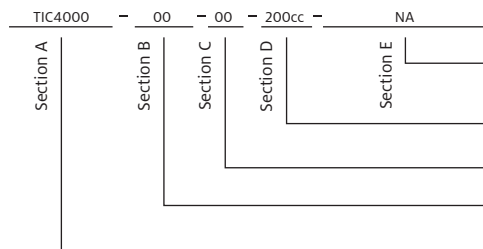

### Standard Options

◀ example

NA = Selected standard option. If not selecting a standard option, insert company name, drawing number, and revision level.

Containers: 5cc = 5.0cc, 25cc = 25.0cc, 200cc = 200.0cc

00 = No options

00 = No options

TIC4000 = Thermal Interface Compound 4000

Note: To build a part number, go to [www.bergquistcompany.com/Part\\_Number\\_Builder.php](http://www.bergquistcompany.com/Part_Number_Builder.php).



# LIQUI-FORM 2000

## Thermally Conductive, One-Part, Liquid Formable Material

### Features and Benefits

- Thermal conductivity: 2.0 W/m-K
- Applies very low force on components during assembly
- Low volumetric expansion
- Excellent chemical and mechanical stability even at higher temperatures
- No curing required
- Stable viscosity in storage and in the application

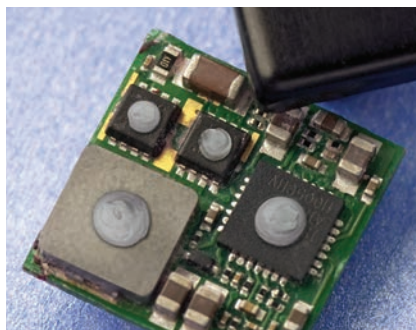

LIQUI-FORM 2000 is a high thermal conductivity liquid formable material designed for demanding applications requiring a balance between dispensability, low component stresses during assembly and ease of rework.

LIQUI-FORM 2000 is a highly conformable, shear-thinning material which requires no curing, mixing or refrigeration. Its unique formulation assures excellent thermal performance, low applied stress and reliable long-term performance. LIQUI-FORM 2000 is thixotropic and has a natural tack, ensuring it forms around the component and stays in place in the application.

### TYPICAL PROPERTIES OF LIQUI-FORM 2000

PROPERTY	IMPERIAL VALUE	METRIC VALUE	TEST METHOD	
Color	Grey	Grey	Visual	
Low Shear Viscosity (Pa-s) @ 0.01 sec <sup>-1</sup> (1)	20,000	20,000	ASTM D4473	
High Shear Viscosity (Pa-s) @ 300 sec <sup>-1</sup> (2)	110	110	ASTM D2196	
Volumetric Expansion (25 to 275°C), ppm/K	600	600	ASTM E228 modified	
Outgassing, % Total Mass Loss	0.53	0.53	ASTM E595	
Density (g/cc)	2.8	2.8	ASTM D792	
Continuous Use Temp. (°F) / (°C)	-76 to 392	-60 to 200	—	
Shelf Life at 25°C (Months)	6	6	—	
<b>ELECTRICAL</b>				
Dielectric Strength (V/mil)/(V/mm)	250	10,000	ASTM D149	
Dielectric Constant (1,000 Hz)	8.0	8.0	ASTM D150	
Volume Resistivity (Ohmmeter)	10 <sup>9</sup>	10 <sup>9</sup>	ASTM D257	
Flame Rating	V-O	V-O	UL 94	
<b>THERMAL</b>				
Thermal Conductivity (W/m-K)	2.0	2.0	ASTM D5470	
<b>THERMAL PERFORMANCE VS. PRESSURE</b>				
	Pressure (PSI)	10	25	50
	Thermal Impedance (°C-in. <sup>2</sup> /W) <sup>(3)</sup>	0.13	0.12	0.12

1) Parallel Plate Rheometer, See Product Management Liqui-Form Application Note on our website under Liquid Thermal Interface Materials.  
 2) Capillary Rheometer, See Product Management for Viscosity and Dispensing Application Note.  
 3) The ASTM D5470 test fixture was used. The recorded values include the interfacial thermal resistance. The values are provided for reference only. Actual application performance is directly related to the surface roughness, flatness and pressure applied.

### Typical Applications Include:

- Bare die to heat spreader lid
- Filling various gaps between heat-generating devices to heat sinks and housings
- Devices requiring low assembly pressure
- BGA, PGA, PPGA

### Configurations Available:

- Supplied in 30 cc or 600 cc cartridges or 5 gallon pails

### Building a Part Number

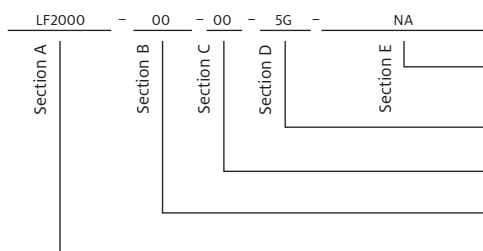

### Standard Options

◀ **example**  
 NA = Selected standard option. If not selecting a standard option, insert company name, drawing number, and revision level.  
 Cartridges: 30cc = 30.0cc, 600cc = 600.0cc  
 Pails: 5G = 5 gallon  
 00: No options  
 00 = No spacer beads  
 07 = 0.007" spacer beads  
 LF2000 = LIQUI-FORM 2000 Material

Note: To build a part number, go to [www.bergquistcompany.com/Part\\_Number\\_Builder.php](http://www.bergquistcompany.com/Part_Number_Builder.php).

# LIQUI-FORM 3500

## Thermally Conductive, One-Part, Liquid Formable Gel Material

### Features and Benefits

- Thermal Conductivity: 3.5 W/m-K
- Dispensable pre-cured gel
- Stable viscosity in storage and in the application
- Excellent chemical stability and mechanical stability



LIQUI-FORM 3500 is a high conductivity gel thermal interface material designed for demanding applications that require a balance between dispensability and low component stress during assembly and also in the application.

LIQUI-FORM 3500 is a one-part, highly conformable gel with thixotropic properties. The material is precured and requires no curing, mixing or refrigeration. It's unique formulation assures excellent thermal performance, low applied stress and reliable long-term performance.

LIQUI-FORM 3500 is thixotropic with a natural tack ensuring it will stay in place within the application.

### TYPICAL PROPERTIES OF LIQUI-FORM 3500

PROPERTY	IMPERIAL VALUE	METRIC VALUE	TEST METHOD	
Color	Gray	Gray	Visual	
Dispense Rate (Grams/min) <sup>(1)</sup>	40	40	Henkel Test	
Volumetric Expansion (25 to 275°C), ppm/K	200	200	ASTM E228 modified	
Outgassing, % Total Mass Loss	0.14	0.14	ASTM E595	
Density (g/cc)	3.1	3.1	ASTM D792	
Continuous Use Temp (°F) / (°C)	-76 to 392	-60 to 200	—	
Shelf Life at 25°C (Months)	6	6	—	
<b>ELECTRICAL</b>				
Dielectric Strength (V/mil)/(V/mm)	250	10,000	ASTM D149	
Dielectric Constant (1000 Hz)	8.1	8.1	ASTM D150	
Volume Resistivity (Ohm-meter)	10 <sup>11</sup>	10 <sup>11</sup>	ASTM D257	
Flame Rating	V-O	V-O	U.L. 94	
<b>THERMAL</b>				
Thermal Conductivity (W/m-K)	3.5	3.5	ASTM D5470	
<b>THERMAL PERFORMANCE VS. PRESSURE</b>				
	Pressure (PSI)	10	25	50
	Thermal Impedance(°C-in <sup>2</sup> /W) <sup>(2)</sup>	0.07	0.07	0.06

(1) 30cc syringe, 90 psi (621 kPa), 0.100" orifice no attachment.  
 (2) The ASTM D5470 test fixture was utilized. The recorded values include the interfacial thermal resistance. The values are provided for reference only. Actual application performance is directly related to the surface roughness, flatness and pressure applied.

### Typical Applications Include:

- Handheld devices
- Bare die to heat spreader lid
- Filling various gaps between heat-generating devices to heat sinks and housings
- Devices requiring low assembly pressure
- High value assemblies with rework
- BGA, PGA, PPGA

### Configurations Available:

- Supplied in 30cc, 150cc, 300cc, 600cc cartridges or 4.3 gallon pails

### Building a Part Number

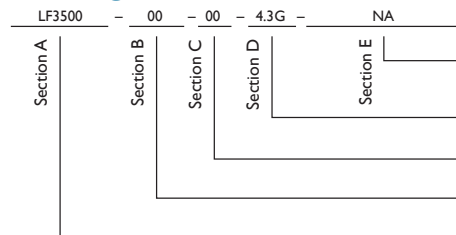

### Standard Options

« example

NA = Selected standard option. If not selecting a standard option, insert company name, drawing number, and revision level.

Cartridges: 30cc = 30.0cc, 150cc = 150.0cc, 300cc = 300.0cc  
 Pails: 4.3G = 4.3 gallon

00: No options

00 = No spacer beads

LF3500 = LIQUI-FORM 3500 Material

Note: To build a part number, visit our website at [www.bergquistcompany.com/Part\\_Number\\_Builder.php](http://www.bergquistcompany.com/Part_Number_Builder.php).

# HI-FLOW Phase Change Interface Materials

## Solutions-Driven Thermal Management Products for Electronic Devices

### Use phase change materials for excellent thermal performance without the mess of grease.

HI-FLOW phase change materials are an excellent replacement for grease as a thermal interface between a CPU or power device and a heat sink. The materials change from a solid at specific phase change temperatures and flow to assure a total wet-out of the interface without overflow. The result is a thermal interface comparable to grease, without the mess, contamination and hassle.

The HI-FLOW family of phase change thermal interface materials covers a wide range of applications. Henkel's BERGQUIST brand offers leading thermal management solutions and we work closely with customers to ensure that the proper HI-FLOW material is specified.

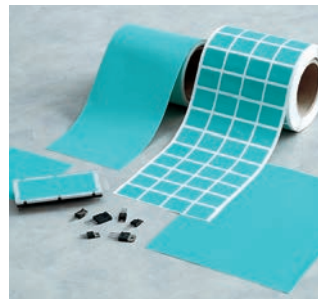
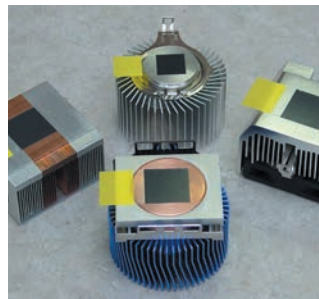
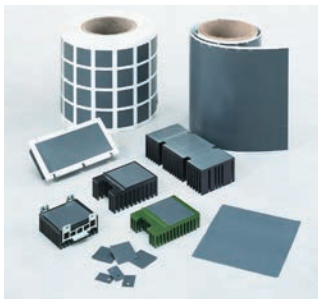

### Features

HI-FLOW handles like BERGQUIST SIL PAD materials at room temperature, but flows like grease at its designed phase change temperature. The following is an overview of the important features shared by the HI-FLOW family:

- Comparable thermal performance to grease in most applications
- Thermally conductive phase change compound
- Aluminum, film or fiberglass carriers and non-reinforced versions
- Low volatility
- Easy to handle and apply in the manufacturing environment
- Tackified or tack-free at room temperature

### Benefits

Using HI-FLOW materials instead of grease can save time and money without sacrificing thermal performance. Here are some other benefits:

- No mess – thixotropic characteristics of the materials keep it from flowing out of the interface
- Easier handling – tackified or tack-free at room temperature
- No protective liner required
- High thermal performance helps ensure CPU reliability
- Do not attract contaminants
- Easier material handling and shipping
- Simplified application process

### Options

The broad HI-FLOW family offers a variety of choices to meet the customer's performance, handling and process needs. Some of the choices include:

- Some HI-FLOW materials are available with or without adhesive
- Aluminum carrier for applications not requiring electrical isolation
- Film or fiberglass carrier for electrical isolation
- Dry, non-reinforced material
- Tackified or tack-free at room temperature
- Tabbed parts, die-cut parts, sheets or bulk rolls
- Adhesive specifically for cold application without preheating heat sink

We produce thousands of specials. Tooling charges vary depending on the complexity of the part.

### Applications

HI-FLOW materials are suited for consumer and industrial electronics, automotive, medical, aerospace and telecommunications applications such as:

- UPS and SMPS AC/DC, DC/DC or linear power supplies
- Between a CPU and heat sink
- Power conversion devices
- Fractional and integral motor control
- Leaded, surface mount and power module assemblies

# HI-FLOW Comparison Data

## TO-220 Thermal Performance

Isolating HI-FLOW Series 300p to 650P Grease Replacement Materials

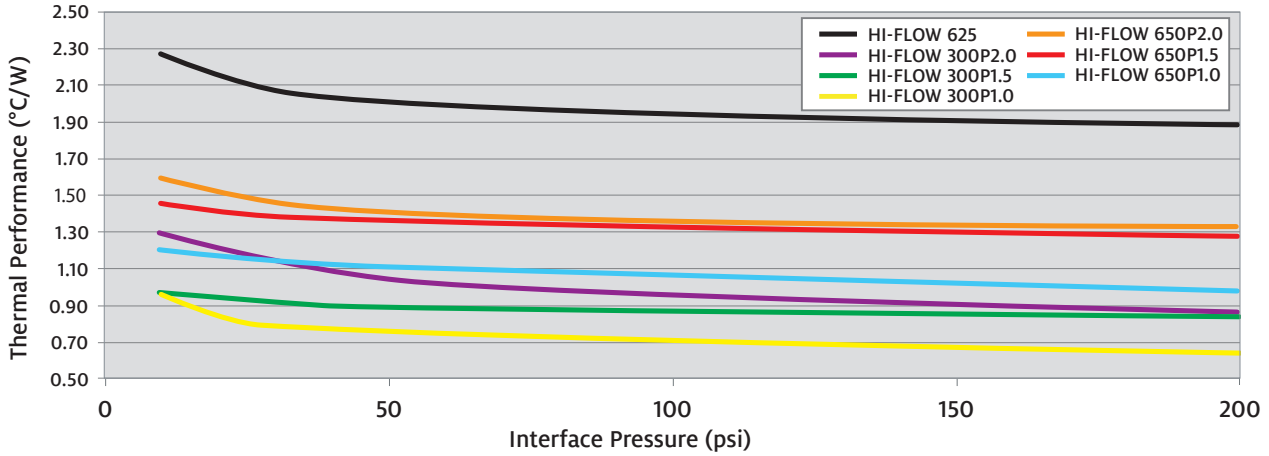

Non-Isolating HI-FLOW Series 105 Grease Replacement Materials

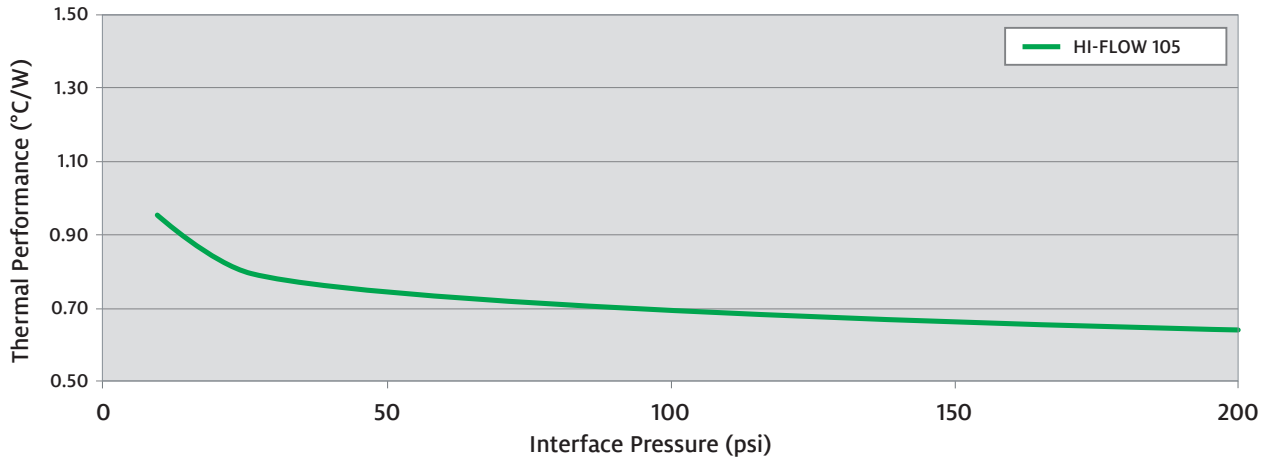

Non-Isolating HI-FLOW 225 to 565 Grease Replacement Materials

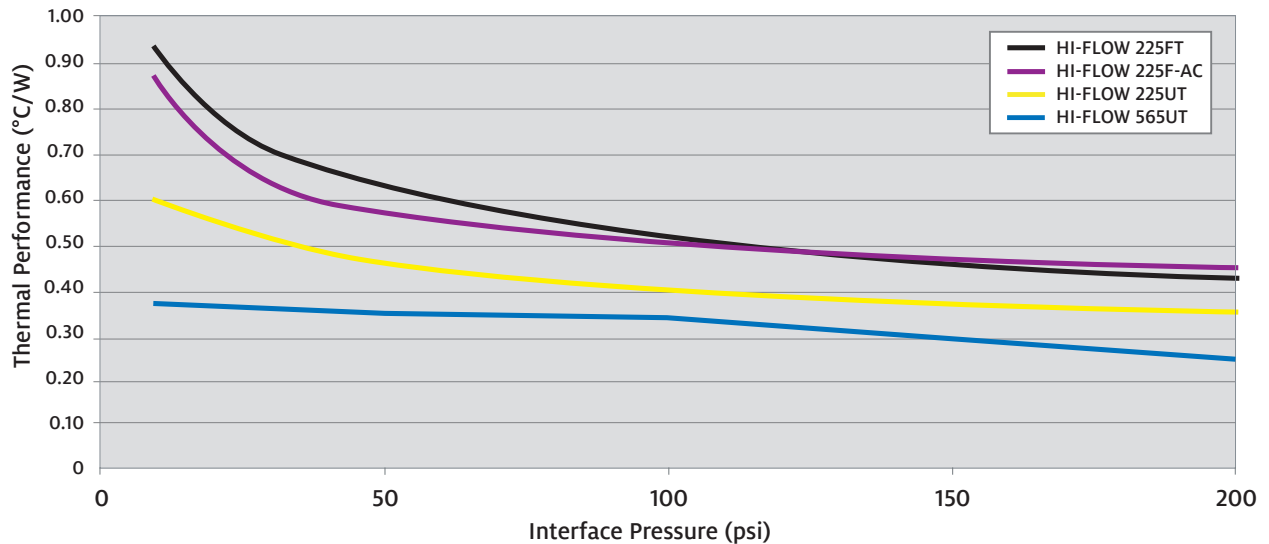

## Frequently Asked Questions

**Q: How is the ASTM D5470 test modified to characterize phase change thermal performance?**

**A:** ASTM classifies a phase change as a Type 1, viscous liquid that exhibits unlimited deformation when a stress is applied. Henkel uses test equipment that is designed to meet ASTM D5470 specifications for Type 1, which requires a shim or mechanical stop to precisely control the thickness. The phase change material is conditioned at 5°C over the stated phase change temperature. Understanding that time is also a key variable for material flow, the over-temperature condition is limited to 10 minutes and then allowed to cool, prior to initiating the actual test at the given pressure. The 10-minute time has been demonstrated to be an acceptable time period for the thermal mass inherent in the test setup. Note: Actual application testing may require more or less time to condition, depending upon the heat transfer and associated thermal mass. The performance values are recorded and published at 10, 25, 50, 100 and 200 psi to give the designer a broad-based understanding of HI-FLOW material's performance.

**Q: What is the minimum pressure required to optimize the thermal performance of the HI-FLOW material?**

**A:** Upon achieving phase change temperature (e.g., pre-conditioning), Henkel has demonstrated that 10 psi provides adequate pressure to achieve exceptional thermal performance. Henkel continues to research lower pressure wet-out characteristics in an effort to minimize interfacial losses associated with ultra-thin material interfaces.

**Q: Will the HI-FLOW replace a mechanical fastener?**

**A:** Mechanical fasteners are required. Henkel recommends the use of spring clips to maintain consistent pressure over time.

**Q: Can I use screw-mount devices with HI-FLOW material?**

**A:** HI-FLOW works best with a clip or spring washer-mounted assembly. The continuous force applied by these devices allows the HI-FLOW material to flow and reduce the cross sectional gap. Henkel suggests that design engineers evaluate whether a screw-mount assembly will have acceptable performance. See TO-220 Technical Note.

**Q: Is the adhesive in HI-FLOW 225F-AC repositionable?**

**A:** The adhesive in the current construction does adhere more to the heat sink aluminum than to the HI-FLOW material. There is the potential that the adhesive will be removed by the heat sink surface when it is removed to reposition on the heat sink. Time and/or pressure will increase the bond to the aluminum, increasing the potential for the adhesive to adhere to the heat sink.

**Q: Is there any surface preparation required before applying the adhesive-backed HI-FLOW to the heat sink?**

**A:** Standard electronics industry cleaning procedures apply. Remove dirt or other debris. Best results are attained when the HI-FLOW material is applied to a heat sink at a temperature of 25° +/- 10°C. If the heat sink has been surface treated (e.g., anodized or chromated), it is typically ready for assembly. For

bare aluminum, mild soap and water wash cleaning processes are typically used to eliminate machine oils and debris.

**Q: Is HI-FLOW material reworkable?**

**A:** If the material has not gone through phase change, the material will readily release from the device surface. For this situation, the HI-FLOW material will not likely have to be replaced.

If the material has gone through the phase change, it will adhere very well to both surfaces. In this case, Henkel suggests warming the heat sink to soften the HI-FLOW compound for easier removal from the processor. Replace with a new piece of HI-FLOW material.

**Q: What is meant by “easy to handle” in manufacturing?**

**A:** Insulated HI-FLOW products are manufactured with inner film support. This film stiffens the material, allowing parts to be more readily die-cut as well as making the material easier to handle in manual or automated assembly.

**Q: What is meant by “tack-free” and why is this important?**

**A:** Many HI-FLOW materials have no surface tack at room temperature. The softer materials will pick up dirt more readily. Softer resins are more difficult to clean if any dirt is on the surface. If you try to rub the dirt away, the dirt is easily pushed into the soft phase change materials. HI-FLOW coatings are typically hard at room temperature rendering them easier to clean off without embedding dirt.

**Q: What does “more scratch resistance” mean on HI-FLOW 625?**

**A:** HI-FLOW 625 does not require a protective film during shipment. HI-FLOW has a higher phase change temperature and remains hard to a higher temperature. The HI-FLOW material is harder and is not as easy to scratch or dent in shipping and handling.

**Q: Why is HI-FLOW phase change temperature 65°C?**

**A:** The 65°C phase change temperature was selected for two reasons. First, it was a low enough temperature for the phase change to occur in applications. Second, it would not phase change in transport. Studies show that shipping containers can reach 60°C in domestic and international shipments. The higher phase change temperature eliminates the possibility of a product being ruined in shipment. We offer a standard line of HI-FLOW 225 and 300 series products with 55°C phase change for those customers wanting the lower phase change temperature.

**Q: In which applications should I avoid using HI-FLOW?**

**A:** Avoid using HI-FLOW in applications in which the device will not reach operation at or above phase change temperature. Also avoid applications in which the operating temperature exceeds the maximum recommended operating temperature of the compound.



# HI-FLOW 105

## Phase Change Coated Aluminum

### Features and Benefits

- Thermal impedance: 0.37°C-in.<sup>2</sup>/W (@ 25 psi)
- Used where electrical isolation is not required
- Low volatility – less than 1%
- Easy to handle in the manufacturing environment
- Flows but doesn't run like grease

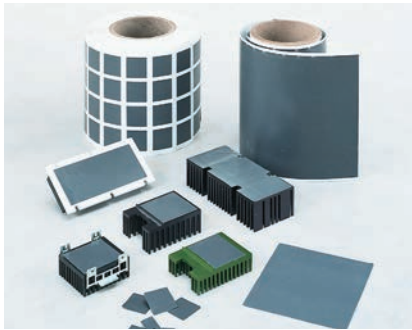

HI-FLOW 105 is a phase change material coated on both sides of an aluminum substrate. It is designed specifically to replace grease as a thermal interface, eliminating the mess, contamination and difficult handling associated with grease. HI-FLOW 105 is tack-free and scratch-resistant at room temperature, and does not require a protective liner in shipment when attached to a heat sink.

At 65°C (phase change temperature), HI-FLOW 105 changes from a solid and flows, thereby assuring total wet-out of the interface. The thixotropic characteristics of HI-FLOW 105 reduce the pump-out from the interface.

HI-FLOW 105 has thermal performance equal to grease with 0.10°C-in.<sup>2</sup>/W contact thermal resistance.

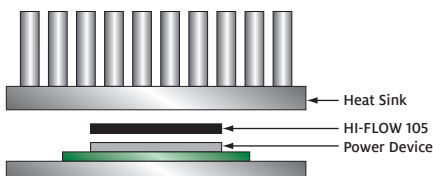

### TYPICAL PROPERTIES OF HI-FLOW 105

PROPERTY	IMPERIAL VALUE	METRIC VALUE	TEST METHOD			
Color	Dark Grey	Dark Grey	Visual			
Reinforcement Carrier	Aluminum	Aluminum	—			
Thickness (in.) / (mm)	0.0055	0.139	ASTM D374			
Continuous Use Temp. (°F) / (°C)	266	130	—			
Phase Change Temp. (°F) / (°C)	149	65	ASTM D3418			
<b>ELECTRICAL</b>						
Dielectric Constant (1,000 (Hz))	3.2	3.2	ASTM D150			
Flame Rating	V-O	V-O	UL 94			
<b>THERMAL</b>						
Thermal Conductivity (W/m-K) <sup>(1)</sup>	0.9	0.9	ASTM D5470			
<b>THERMAL PERFORMANCE VS. PRESSURE</b>						
	Pressure (psi)	10	25	50	100	200
	TO-220 Thermal Performance (°C/W)	0.95	0.80	0.74	0.69	0.64
	Thermal Impedance (°C-in. <sup>2</sup> /W) <sup>(2)</sup>	0.39	0.37	0.36	0.33	0.30
<p>1) This is the measured thermal conductivity of the HI-FLOW coating. It represents one conducting layer in a three-layer laminate. The HI-FLOW coatings are phase change compounds. These layers will respond to heat and pressure induced stresses. The overall conductivity of the material in post-phase change, thin film products is highly dependent upon the heat and pressure applied. This characteristic is not accounted for in ASTM D5470. Please contact Henkel if additional specifications are required.</p> <p>2) The ASTM D5470 test fixture was used and the test sample was conditioned at 70°C prior to test. The recorded value includes interfacial thermal resistance. These values are provided for reference only. Actual application performance is directly related to the surface roughness, flatness and pressure applied.</p>						

### Typical Applications Include:

- Power semiconductors
- Microprocessors mounted on a heat sink
- Power conversion modules
- Spring or clip-mount applications where thermal grease is used

### Configurations Available:

- Sheet form, die-cut parts and roll form
- With or without pressure sensitive adhesive

### Building a Part Number

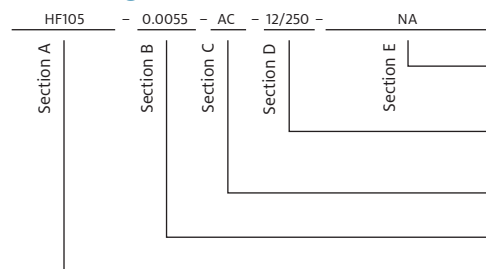

### Standard Options

◀ example

NA = Selected standard option. If not selecting a standard option, insert company name, drawing number, and revision level.

\_\_\_ = Standard configuration dash number, 1212 = 12' x 12' sheets, 12/250 = 12' x 250-foot rolls, or 00 = custom configuration

AC = Adhesive, one side  
00 = No adhesive

Standard thicknesses available: 0.0055"

HF105 = HI-FLOW 105 Phase Change Material

Note: To build a part number, go to [www.bergquistcompany.com/Part\\_Number\\_Builder.php](http://www.bergquistcompany.com/Part_Number_Builder.php).



# HI-FLOW 225F-AC

## Reinforced, Phase Change Thermal Interface Material

### Features and Benefits

- Thermal impedance: 0.10°C-in.<sup>2</sup>/W (@ 25 psi)
- Can be manually or automatically applied to the surfaces of room-temperature heat sinks
- Foil-reinforced, adhesive-coated
- Soft, thermally conductive 55°C phase change compound

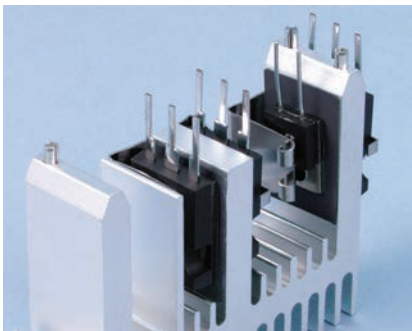

HI-FLOW 225F-AC is a high performance, thermal interface material for use between a computer processor and a heat sink. HI-FLOW 225F-AC consists of a soft, thermally conductive 55°C phase change compound coated to the top surface of an aluminum carrier with a soft, thermally conductive adhesive compound coated to the bottom surface to improve adhesion to the heat sink.

Above the 55°C phase change temperature, HI-FLOW 225F-AC wets-out the thermal interface surfaces and flows to produce low thermal impedance.

HI-FLOW 225F-AC requires pressure from the assembly to cause material flow. The HI-FLOW coatings resist dripping in vertical orientation.

The material includes a base carrier liner with differential release properties to facilitate simplicity in roll form packaging and application assembly. Please contact Henkel Product Management for applications that are less than 0.07 inch squared.

TYPICAL PROPERTIES OF HI-FLOW 225F-AC						
PROPERTY	IMPERIAL VALUE	METRIC VALUE	TEST METHOD			
Color	Black	Black	Visual			
Reinforcement Carrier	Aluminum	Aluminum	—			
Thickness (in.) / (mm)	0.004	0.102	ASTM D374			
Carrier Thickness (in.) / (mm)	0.0015	0.038	ASTM D374			
Continuous Use Temp. (°F) / (°C)	248	120	—			
Phase Change Temp. (°F) / (°C)	131	55	ASTM D3418			
<b>ELECTRICAL</b>						
Flame Rating	V-O	V-O	UL 94			
<b>THERMAL</b>						
Thermal Conductivity (W/m-K) <sup>(1)</sup>	1.0	1.0	ASTM D5470			
<b>THERMAL PERFORMANCE VS. PRESSURE</b>						
	Pressure (psi)	10	25	50	100	200
	TO-220 Thermal Performance (°C/W)	0.87	0.68	0.57	0.50	0.45
	Thermal Impedance (°C-in. <sup>2</sup> /W) <sup>(2)</sup>	0.12	0.10	0.09	0.08	0.07
<p>1) This is the measured thermal conductivity of the HI-FLOW coating. It represents one conducting layer in a three-layer laminate. The HI-FLOW coatings are phase change compounds. These layers will respond to heat and pressure induced stresses. The overall conductivity of the material in post-phase change, thin film products is highly dependent upon the heat and pressure applied. This characteristic is not accounted for in ASTM D5470. Please contact Henkel Product Management if additional specifications are required.</p> <p>2) The ASTM D5470 test fixture was used and the test sample was conditioned at 70°C prior to test. The recorded value includes interfacial thermal resistance. These values are provided for reference only. Actual application performance is directly related to the surface roughness, flatness and pressure applied.</p>						

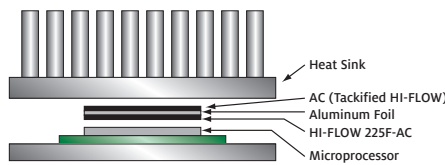

### Typical Applications Include:

- Computer and peripherals
- Power conversion
- High performance computer processors
- Power semiconductors
- Power modules

### Configurations Available:

- Roll form, kiss-cut parts, and sheet form

### Building a Part Number

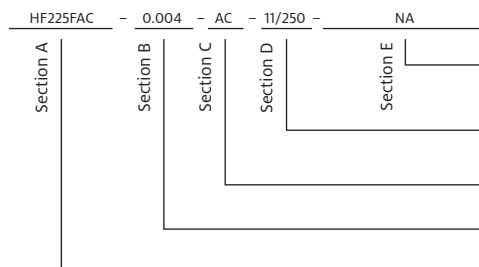

### Standard Options

#### example

NA = Selected standard option. If not selecting a standard option, insert company name, drawing number, and revision level.

\_\_\_ = Standard configuration dash number, 1112 = 11" x 12" sheets, 11/250 = 11" x 250-foot rolls, or 00 = custom configuration

AC = Adhesive, one side

Standard thicknesses available: 0.004"

HF225FAC = HI-FLOW 225F-AC Phase Change Material

Note: To build a part number, go to [www.bergquistcompany.com/Part\\_Number\\_Builder.php](http://www.bergquistcompany.com/Part_Number_Builder.php).

# HI-FLOW 225UT

## Unreinforced, Pressure Sensitive Phase Change Thermal Interface Material

### Features and Benefits

- Thermal impedance: 0.08°C-in.<sup>2</sup>/W (@ 25 psi)
- 55°C phase change composite with inherent tack characteristics
- High-visibility protective tabs
- Pressure sensitive phase change thermal interface material

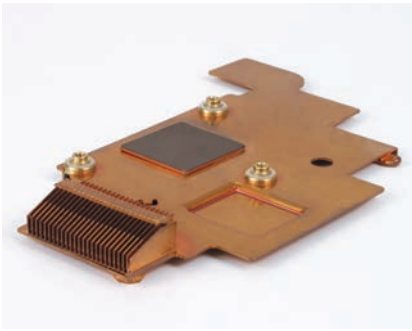

HI-FLOW 225UT is designed as a pressure sensitive thermal interface material for use between a high performance processor and a heat sink. HI-FLOW 225UT is a thermally conductive 55°C phase change composite with inherent tack. The material is supplied on a polyester carrier liner and is available with high-visibility protective tabs.

Above its phase change temperature, HI-FLOW 225UT wets-out the thermal interface surfaces and flows to produce the lowest thermal impedance. The material requires pressure of the assembly to cause flow.

### Application Methods:

Hand-apply HI-FLOW 225UT to a room-temperature heat sink. The HI-FLOW 225UT pad exhibits inherent tack and can be hand-applied similar to an adhesive pad. The tab liner can remain on the heat sink and pad throughout shipping and handling until it is ready for final assembly.

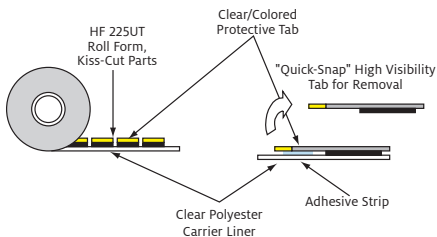

### TYPICAL PROPERTIES OF HI-FLOW 225UT

PROPERTY	IMPERIAL VALUE	METRIC VALUE	TEST METHOD			
Color	Black	Black	Visual			
Reinforcement Carrier	None	None	—			
Thickness (in.) / (mm)	0.003	0.077	ASTM D374			
Continuous Use Temp. (°F) / (°C)	248	120	—			
Phase Change Temp. (°F) / (°C)	131	55	ASTM D3418			
<b>ELECTRICAL</b>						
Flame Rating	V-O	V-O	UL 94			
<b>THERMAL</b>						
Thermal Conductivity (W/m-K) <sup>(1)</sup>	0.7	0.7	ASTM D5470			
<b>THERMAL PERFORMANCE VS. PRESSURE</b>						
	Pressure (psi)	10	25	50	100	200
	TO-220 Thermal Performance (°C/W)	0.60	0.53	0.46	0.40	0.35
	Thermal Impedance (°C-in. <sup>2</sup> /W) <sup>(2)</sup>	0.09	0.08	0.07	0.06	0.05
<p>1) This is the measured thermal conductivity of the HI-FLOW coating. It represents one conducting layer in a three-layer laminate. The HI-FLOW coatings are phase change compounds. These layers will respond to heat and pressure induced stresses. The overall conductivity of the material in post-phase change, thin film products is highly dependent upon the heat and pressure applied. This characteristic is not accounted for in ASTM D5470. Please contact Henkel Product Management if additional specifications are required.</p> <p>2) The ASTM D5470 test fixture was used and the test sample was conditioned at 70°C prior to test. The recorded value includes interfacial thermal resistance. These values are provided for reference only. Actual application performance is directly related to the surface roughness, flatness and pressure applied.</p>						

### Typical Applications Include:

- Computer and peripherals
- High performance computer processors
- Graphic cards
- Power modules

### Configurations Available:

- Roll form with tabs, kiss-cut parts – no holes

HI-FLOW 225UT is limited to a square or rectangular part design. Dimensional tolerance is +/- 0.020 in. (0.5 mm).

### Building a Part Number

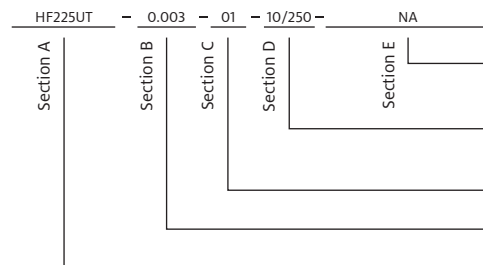

### Standard Options

NA = Selected standard option. If not selecting a standard option, insert company name, drawing number, and revision level.

\_\_\_ = Standard HI-FLOW 225UT configuration, 10/250 = 10" x 250-foot rolls, or 00 = custom configuration

00 = Pressure sensitive adhesive, one side

Standard thicknesses available: 0.003"

HF22UT = HI-FLOW 225UT Phase Change Material

Note: To build a part number, go to [www.bergquistcompany.com/Part\\_Number\\_Builder.php](http://www.bergquistcompany.com/Part_Number_Builder.php).

# HI-FLOW 300P

## Electrically Insulating, Thermally Conductive Phase Change Material

### Features and Benefits

- Thermal impedance: 0.13°C-in.<sup>2</sup>/W (@ 25 psi)
- Field-proven polyimide film: excellent dielectric performance; excellent cut-through resistance
- Outstanding thermal performance in an insulated pad

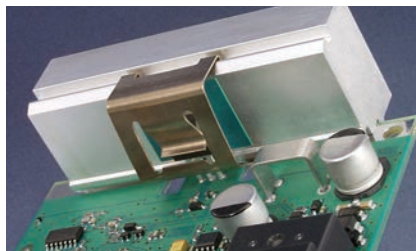

HI-FLOW 300P consists of a thermally conductive 55°C phase change compound coated on a thermally conductive polyimide film. The polyimide reinforcement makes the material easy to handle and the 55°C phase change temperature minimizes shipping and handling problems.

HI-FLOW 300P achieves outstanding values in voltage breakdown and thermal performance. The product is supplied on an easy release liner for exceptional handling in high volume manual assemblies. HI-FLOW 300P is designed for use as a thermal interface material between electronic power devices requiring electrical isolation to the heat sink.

Henkel suggests the use of spring clips to assure constant pressure with the interface and power source. Please refer to thermal performance data to determine nominal spring pressure for your application.

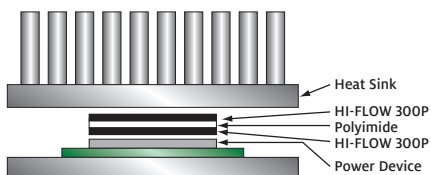

We produce thousands of specials. Tooling charges vary depending on tolerances and complexity of the part.

### TYPICAL PROPERTIES OF HI-FLOW 300P

PROPERTY	IMPERIAL VALUE	METRIC VALUE	TEST METHOD			
Color	Green	Green	Visual			
Reinforcement Carrier	Polyimide	Polyimide	—			
Thickness (in.) / (mm)	0.004 - 0.005	0.102 - 0.127	ASTM D374			
Film Thickness (in.) / (mm)	0.001 - 0.002	0.025 - 0.050	ASTM D374			
Elongation (%)	40	40	ASTM D882A			
Tensile Strength (psi) / (mPa)	7,000	48	ASTM D882A			
Continuous Use Temp. (°F) / (°C)	302	150	—			
Phase Change Temp. (°F) / (°C)	131	55	ASTM D3418			
<b>ELECTRICAL</b>						
Dielectric Breakdown Voltage (Vac.)	5,000	5,000	ASTM D149			
Dielectric Constant (1,000 Hz)	4.5	4.5	ASTM D150			
Volume Resistivity (Ohmmeter)	10 <sup>12</sup>	10 <sup>12</sup>	ASTM D257			
Flame Rating	V-O	V-O	UL 94			
<b>THERMAL</b>						
Thermal Conductivity (W/m-K) <sup>(1)</sup>	1.6	1.6	ASTM D5470			
<b>THERMAL PERFORMANCE VS. PRESSURE</b>						
	Pressure (psi)	10	25	50	100	200
TO-220 Thermal Performance (°C/W) 0.0010 in.		0.95	0.94	0.92	0.91	0.90
TO-220 Thermal Performance (°C/W) 0.0015 in.		1.19	1.17	1.16	1.14	1.12
TO-220 Thermal Performance (°C/W) 0.0020 in.		1.38	1.37	1.35	1.33	1.32
Thermal Impedance (°C-in. <sup>2</sup> /W) 0.0010 in. <sup>(2)</sup>		0.13	0.13	0.12	0.12	0.12
Thermal Impedance (°C-in. <sup>2</sup> /W) 0.0015 in. <sup>(2)</sup>		0.17	0.16	0.16	0.16	0.15
Thermal Impedance (°C-in. <sup>2</sup> /W) 0.0020 in. <sup>(2)</sup>		0.19	0.19	0.19	0.18	0.18

1) This is the measured thermal conductivity of the HI-FLOW coating. It represents one conducting layer in a three-layer laminate. The HI-FLOW coatings are phase change compounds. These layers will respond to heat and pressure induced stresses. The overall conductivity of the material in post-phase change, thin film products is highly dependent upon the heat and pressure applied. This characteristic is not accounted for in ASTM D5470. Please contact Henkel Product Management if additional specifications are required.

2) The ASTM D5470 test fixture was used and the test sample was conditioned at 70°C prior to test. The recorded value includes interfacial thermal resistance. These values are provided for reference only. Actual application performance is directly related to the surface roughness, flatness and pressure applied.

### Typical Applications Include:

- Spring / clip-mounted
- Discrete power semiconductors and modules

### Configurations Available:

- Roll form, die-cut parts and sheet form, dry both sides

### Building a Part Number

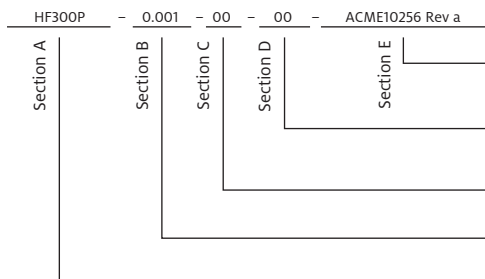

### Standard Options

◀ example  
 NA = Selected standard option. If not selecting a standard option, insert company name, drawing number, and revision level.  
 10.512 = 10.5" x 12" sheets, 10.5/250 = 10.5" x 250-foot rolls, or 00 = custom configuration  
 00 = No adhesive  
 Standard polyimide thicknesses available: 0.001", 0.0015", 0.002"  
 HF300P = HI-FLOW 300P Phase Change Material

Note: To build a part number, go to [www.bergquistcompany.com/Part\\_Number\\_Builder.php](http://www.bergquistcompany.com/Part_Number_Builder.php).

# HI-FLOW 565UT

## Tacky, High Performance, Phase Change TIM

### Features and Benefits

- Thermal impedance: 0.05°C-in.<sup>2</sup>/W (@ 25 psi)
- High thermal conductivity: 3.0 W/mk
- Phase change softening temp. 52°C
- Naturally tacky
- Tabulated for ease of assembly

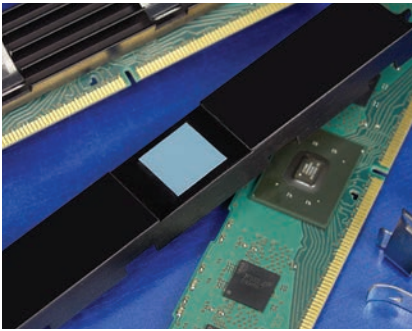

HI-FLOW 565UT is a naturally tacky, thermally conductive phase change material which is supplied in an easy to use tabulated pad form. In the application the material undergoes a phase change softening, starting near 52°C. The phase change softening feature improves handling characteristics prior to a facilitated assembly. At application temperatures and pressures, HI-FLOW 565UT wets out the thermal interfaces producing a very low thermal impedance.

The thermal performance of HI-FLOW 565UT is comparable to the best thermal greases. HI-FLOW 565UT is provided at a consistent thickness to ensure reliable performance. HI-FLOW 565UT can be applied in high volumes to the target surface via low pressure from a roller or manual application.

### TYPICAL PROPERTIES OF HI-FLOW 565UT

PROPERTY	IMPERIAL VALUE	METRIC VALUE	TEST METHOD			
Color	Blue	Blue	Visual			
Reinforcement Carrier	None	None	—			
Thickness (in.) / (mm)	0.005, 0.010	0.127, 0.254	ASTM D374			
Continuous Use Temp. (°F) / (°C)	257	125	—			
Phase Change Softening Temp. (°F) / (°C)	126	52	ASTM D3418			
<b>ELECTRICAL</b>						
Flame Rating	V-O	V-O	UL 94			
<b>THERMAL</b>						
Thermal Conductivity (W/m-K) <sup>(1)</sup>	3.0	3.0	ASTM D5470			
<b>THERMAL PERFORMANCE VS. PRESSURE</b>						
	Pressure (psi)	10	25	50	100	200
	TO-220 Thermal Performance (°C/W)	0.37	0.35	0.34	0.30	0.26
	Thermal Impedance (°C-in. <sup>2</sup> /W) <sup>(2)</sup>	0.09	0.05	0.03	0.02	0.02
<p>1) This is the measured thermal conductivity of the HI-FLOW coating. It represents one conducting layer in a three-layer laminate. The HI-FLOW coatings are phase change compounds. These layers will respond to heat and pressure induced stresses. The overall conductivity of the material in post-phase change, thin film products is highly dependent upon the heat and pressure applied. This characteristic is not accounted for in ASTM D5470. Please contact Henkel Product Management if additional specifications are required.</p> <p>2) The ASTM D5470 test fixture was used and the test sample was conditioned at 70°C prior to test. The recorded value includes interfacial thermal resistance. These values are provided for reference only. Actual application performance is directly related to the surface roughness, flatness and pressure applied.</p>						

### Typical Applications Include:

- Processor lid to heat sink
- Processor die to lid or heat sink
- FBDIMM to heat spreader

### Configurations Available:

- Tabulated in roll form, kiss-cut parts – no holes
- HI-FLOW 565UT is limited to a square or rectangular part design. Dimensional tolerance is +/- 0.020 in. (0.5 mm)

### Building a Part Number

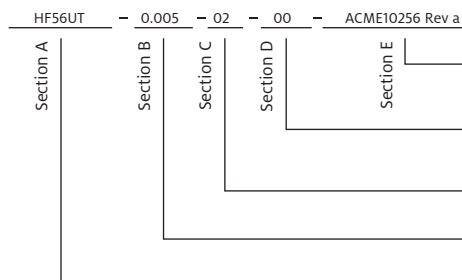

### Standard Options

◀ example

NA = Selected standard option. If not selecting a standard option, insert company name, drawing number, and revision level.

\_\_\_ = Standard HI-FLOW 225UT configuration, 10/250 = 10" x 250-foot rolls, or 00 = custom configuration

02 = Natural Tack

Standard thicknesses available: 0.005", 0.010", 0.016"

HF565UT = HI-FLOW 565UT Phase Change Material

Note: To build a part number, go to [www.bergquistcompany.com/Part\\_Number\\_Builder.php](http://www.bergquistcompany.com/Part_Number_Builder.php).

# HI-FLOW 625

## Reinforced Phase Change Thermal Interface Material

### Features and Benefits

- Thermal impedance: 0.71°C-in.<sup>2</sup>/W (@ 25 psi)
- Electrically isolating
- 65°C phase change compound coated on PEN film
- Tack-free and scratch-resistant



HI-FLOW 625 is a film-reinforced phase change material. The product consists of a thermally conductive 65°C phase change compound coated on PEN film. HI-FLOW 625 is designed to be used as a thermal interface material between electronic power devices that require electrical isolation and a heat sink. The reinforcement makes HI-FLOW 625 easy to handle, and the 65°C phase change temperature of the coating material eliminates shipping and handling problems. The PEN film has a continuous use temperature of 150°C.

HI-FLOW 625 is tack-free and scratch-resistant at production temperature and does not require a protective liner in most shipping situations. The material has the thermal performance of 2-3 mil mica and grease assemblies.

### TYPICAL PROPERTIES OF HI-FLOW 625

PROPERTY	IMPERIAL VALUE	METRIC VALUE	TEST METHOD			
Color	Green	Green	Visual			
Reinforcement Carrier	PEN Film	PEN Film	—			
Thickness (in.) / (mm)	0.005	0.127	ASTM D374			
Elongation (% 45° to Warp and Fill)	60	60	ASTM D882A			
Tensile Strength (psi) / (mPa)	30,000	206	ASTM D882A			
Continuous Use Temp. (°F) / (°C)	302	150	—			
Phase Change Temp. (°F) / (°C)	149	65	ASTM D3418			
<b>ELECTRICAL</b>						
Dielectric Breakdown Voltage (Vac.)	4,000	4,000	ASTM D149			
Dielectric Constant (1,000 Hz)	3.5	3.5	ASTM D150			
Volume Resistivity (Ohmmeter)	10 <sup>10</sup>	10 <sup>10</sup>	ASTM D257			
Flame Rating	V-O	V-O	UL 94			
<b>THERMAL</b>						
Thermal Conductivity (W/m-K) <sup>(1)</sup>	0.5	0.5	ASTM D5470			
<b>THERMAL PERFORMANCE VS. PRESSURE</b>						
	Pressure (psi)	10	25	50	100	200
	TO-220 Thermal Performance (°C/W)	2.26	2.10	2.00	1.93	1.87
	Thermal Impedance (°C-in. <sup>2</sup> /W) <sup>(2)</sup>	0.79	0.71	0.70	0.67	0.61
<p>1) This is the measured thermal conductivity of the HI-FLOW coating. It represents one conducting layer in a three-layer laminate. The HI-FLOW coatings are phase change compounds. These layers will respond to heat and pressure induced stresses. The overall conductivity of the material in post-phase change, thin film products is highly dependent upon the heat and pressure applied. This characteristic is not accounted for in ASTM D5470. Please contact Henkel Product Management if additional specifications are required.</p> <p>2) The ASTM D5470 test fixture was used and the test sample was conditioned at 70°C prior to test. The recorded value includes interfacial thermal resistance. These values are provided for reference only. Actual application performance is directly related to the surface roughness, flatness and pressure applied.</p>						

### Typical Applications Include:

- Spring / clip-mounted
- Power semiconductors
- Power modules

### Configurations Available:

- Sheet form, die-cut parts and roll form
- With or without pressure sensitive adhesive

### Building a Part Number

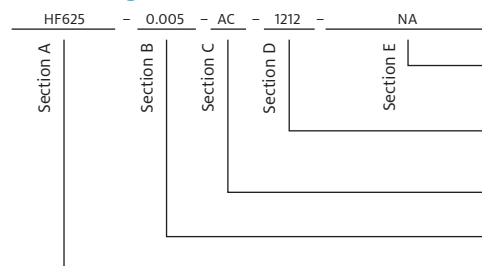

### Standard Options

◀ example

NA = Selected standard option. If not selecting a standard option, insert company name, drawing number, and revision level.

1212 = 12" x 12" sheets, 12/200 = 12" x 200-foot rolls, or 00 = custom configuration

AC = Adhesive, one side  
00 = No adhesive

Standard thicknesses available: 0.005"

HF625 = HI-FLOW 625 Phase Change Material

Note: To build a part number, go to [www.bergquistcompany.com/Part\\_Number\\_Builder.php](http://www.bergquistcompany.com/Part_Number_Builder.php).

# HI-FLOW 650P

## Electrically Insulating, High Performance, Thermally Conductive Phase Change Material

### Features and Benefits

- Thermal Impedance: 0.20°C-in.<sup>2</sup>/W (@ 25 psi)
- 150°C high temperature reliability
- Natural tack on one side for ease of assembly
- Exceptional thermal performance in an insulated pad

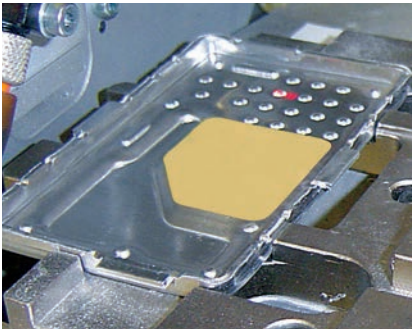

HI-FLOW 650P is a thermally conductive phase change material, reinforced with a polyimide film that is naturally tacky on one side. The polyimide film provides a high dielectric strength and high cut through resistance. HI-FLOW 650P offers high temperature reliability ideal for automotive applications.

HI-FLOW 650P is designed for use between a high-power electrical device requiring electrical isolation from the heat sink and is ideal for automated dispensing systems.

Henkel recommends the use of spring clips to assure constant pressure with the component interface and the heat sink. Please refer to the TO-220 thermal performance data to determine the nominal spring pressure for your application.

### TYPICAL PROPERTIES OF HI-FLOW 650P

PROPERTY	IMPERIAL VALUE	METRIC VALUE	TEST METHOD			
Color	Gold	Gold	Visual			
Reinforcement Carrier	Polyimide	Polyimide	—			
Thickness (in.) / (mm)	0.0045 - 0.0055	0.114 - 0.140	ASTM D374			
Film Thickness (in.) / (mm)	0.001 - 0.002	0.025 - 0.050	ASTM D374			
Inherent Surface Tack (1- or 2-sided)	1	1	—			
Elongation (%)	40	40	ASTM D882A			
Tensile Strength (psi)	7,000	7,000	ASTM D882A			
Continuous Use Temp. (°F / °C)	-40 to 302	-40 to 150	—			
Phase Change Softening Temp. (°F / °C)	126	52	ASTM D3418			
<b>ELECTRICAL</b>						
Dielectric Breakdown Voltage (Vac.)	5,000	5,000	ASTM D149			
Dielectric Constant (1,000 Hz)	4.5	4.5	ASTM D150			
Volume Resistivity (Ohmmeter)	10 <sup>12</sup>	10 <sup>12</sup>	ASTM D257			
Flame Rating	V-O	V-O	UL 94			
<b>THERMAL</b>						
Thermal Conductivity (W/m-K) <sup>(1)</sup>	1.5	1.5	ASTM D5470			
<b>THERMAL PERFORMANCE VS. PRESSURE</b>						
	Pressure (psi)	10	25	50	100	200
	TO-220 Thermal Performance (°C/W) 0.0010 in.	1.20	1.15	1.11	1.06	1.00
	TO-220 Thermal Performance (°C/W) 0.0015 in.	1.47	1.41	1.37	1.33	1.29
	TO-220 Thermal Performance (°C/W) 0.0020 in.	1.59	1.48	1.43	1.38	1.35
	Thermal Impedance (°C-in. <sup>2</sup> /W) <sup>(2)</sup> 0.0010 in.	0.21	0.20	0.19	0.18	0.17
	Thermal Impedance (°C-in. <sup>2</sup> /W) <sup>(2)</sup> 0.0015 in.	0.23	0.22	0.21	0.20	0.20
	Thermal Impedance (°C-in. <sup>2</sup> /W) <sup>(2)</sup> 0.0020 in.	0.27	0.27	0.26	0.25	0.24
<p>1) This is the measured thermal conductivity of the HI-FLOW wax coating. It represents one conducting layer in a three-layer laminate. The HI-FLOW coatings are phase change compounds. These layers will respond to heat and pressure induced stresses. The overall conductivity of the material in post-phase change, thin film products is highly dependent upon the heat and pressure applied. This characteristic is not accounted for in ASTM D5470. Please contact Henkel Product Management if additional specifications are required.</p> <p>2) The ASTM D5470 test fixture was used and the test sample was conditioned at 70°C for 5 minutes prior to test. The recorded value includes interfacial thermal resistance. These values are provided for reference only. Actual application performance is directly related to the surface roughness, flatness and pressure applied.</p>						

### Typical Applications

- Spring / clip-mounted devices
- Discrete power semiconductors and modules

### Configurations Available

- Roll form, die-cut parts, sheet form
- Available with 1.0, 1.5 or 2.0 mil polyimide reinforcement carrier

### Building a Part Number

HF650P - 0.001 - 01 - 00 - ACMEI0256 Rev a

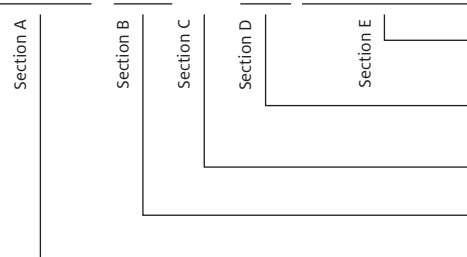

### Standard Options

◀ example

NA = Selected standard option. If not selecting a standard option, insert company name, drawing number, and revision level.

1112 = 11" x 12" sheets, 11/250 = 11" x 250" rolls, or 00 = custom configuration

01 = Natural tack

Standard Polyimide Thicknesses available: 0.001", 0.0015", 0.002"

HF650P = HI-FLOW 650P Phase Change Material

Note: To build a part number, go to [www.bergquistcompany.com/Part\\_Number\\_Builder.php](http://www.bergquistcompany.com/Part_Number_Builder.php).



# SIL PAD Thermally Conductive Insulators

## Solutions-Driven Thermal Management Products for Electronic Devices

### Comprehensive choices for a cleaner and more efficient thermal interface

SIL PAD elastomeric thermal interface material was introduced more than 25 years ago. Today, a complete family of SIL PAD materials is available to meet the needs of a rapidly changing electronics industry.

SIL PAD thermally conductive insulators, in their many forms, continue to be a clean and efficient alternative to mica, ceramics or grease for a wide range of electronic applications. BERGQUIST brand application specialists work closely with customers to specify the proper SIL PAD material for each unique thermal management requirement.

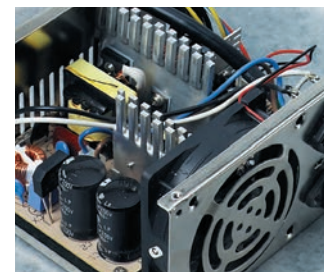

### Features

The SIL PAD family encompasses dozens of products, each with its own unique construction, properties and performance. Here are some of the important features offered by the SIL PAD family:

- Proven silicone rubber binders
- Fiberglass, dielectric film or polyester film carriers
- Special fillers to achieve specific performance characteristics
- Flexible and conformable
- Reinforcements to resist cut-through
- Variety of thicknesses
- Wide range of thermal conductivities and dielectric strengths

### Benefits

Choosing SIL PAD thermal products saves time and money while maximizing an assembly's performance and reliability. Specifically:

- Excellent thermal performance
- Eliminates the mess of grease
- More durable than mica
- Less costly than ceramic
- Resistant to electrical shorting
- Easier and cleaner to apply
- Under time and pressure, thermal resistance will decrease
- Better performance for today's high-heat compacted assemblies
- A specific interfacial performance that matches the need
- Efficient "total applied cost"

### Options

Some SIL PAD products have special features for particular applications. Options include:

- Available with or without adhesive
- Some configurations are well-suited for automated dispensing and/or placement
- Aluminum foil or embedded graphite construction for applications not requiring electrical insulation
- Copper shield layer
- Polyester binder material for silicone-sensitive applications
- Polyimide film carrier for increased voltage breakdown
- Materials with reduced moisture sensitivity
- Available in rolls, sheets, tubes and custom die-cut parts
- Custom thicknesses and constructions

We produce thousands of specials. Tooling charges vary depending on the complexity of the part.

### Applications

The large family of SIL PAD thermally conductive insulators is extremely versatile. In today's marketplace, SIL PAD materials are used in virtually every component of the electronics industry, including:

- Interface between a power transistor, CPU or other heat-generating component and a heat sink or rail
- To isolate electrical components and power sources from heat sink and/or mounting bracket
- As an interface for discrete semiconductors requiring low-pressure spring-clamp mounting
- Consumer electronics
- Automotive systems
- Telecommunications
- Aerospace
- Military
- Medical devices
- Industrial controls

## Frequently Asked Questions

**Q: What is the primary difference between SIL PAD A2000 and SIL PAD 2000 products?**

**A:** SIL PAD A2000 uses a different filler package than SIL PAD 2000. This change results in a more compliant SIL PAD A2000 material that inherently lowers interfacial resistance losses. This reduction in interfacial resistance results in improved overall thermal performance when measured at lower pressures in standard ASTM D5470 and TO-220 testing.

**Q: When should I choose SIL PAD A2000 versus SIL PAD 2000 for my application?**

**A:** The answer is based on the assumption that the primary design intent is to increase thermal performance. If your application uses lower clamping pressures (e.g., 10 to 75 psi), you will find the SIL PAD A2000 to provide excellent thermal performance. In contrast, if you are designing for higher clamping pressures (e.g., 100 psi or greater), it is likely that you will require the thermal performance characteristics of the SIL PAD 2000.

**Q: Are there differences in electrical characteristics between SIL PAD A2000 and SIL PAD 2000?**

**A:** Yes. Henkel evaluates and publishes voltage breakdown, dielectric constant and volume resistivity data per ASTM standards for these materials. Due to differences between ASTM lab testing and actual application performance, for best results, these characteristics should be evaluated within the actual customer system.

**Q: Can I get SIL PAD A2000 in roll form?**

**A:** Yes. With the environmentally responsible process improvements added with the introduction of SIL PAD A2000 products, the materials are now available in roll form. The original SIL PAD 2000 material cannot be produced in continuous roll form.

**Q: When should I choose SIL PAD 800 versus SIL PAD 900S for my application?**

**A:** SIL PAD 800 is specifically formulated to provide excellent thermal performance for discrete semiconductor applications that use low clamping pressures (e.g., spring clips at 10 to 50 psi.). In contrast, if you are designing for higher clamping pressure applications using discrete semi-conductors (e.g., 50 to 100 psi.), it is likely that you will prefer the combination of high thermal performance and cut-through resistance inherent in SIL PAD 900S material.

**Q: When should I choose SIL PAD 980 versus SIL PAD 900S for my application?**

**A:** SIL PAD 980 is specifically formulated to provide exceptional cut-through and crush resistance in combination with excellent heat transfer and dielectric properties. SIL PAD 980 has a proven history of reliability in high-pressure applications where surface imperfections such as burrs and dents are inherently common. These applications often include heavily machined metal surfaces manufactured from extrusions or castings. SIL PAD 900S carries a high level of crush resistance and is more likely to be used in burr-free or controlled-surface finish applications.

**Q: Is there an adhesive available for SIL PAD 1500ST and SIL PAD 1100ST?**

**A:** SIL PAD 1500ST and SIL PAD 1100ST have an inherent tack on both sides of the material. This inherent tack is used instead of an adhesive. The tack provides sufficient adhesive for dispensing from the carrier liner and placement on the component. SIL PAD 1500ST and SIL PAD 1100ST can be repositioned after the initial placement.

**Q: Why are the thermal performance curves of SIL PAD 1500ST and SIL PAD 1100ST so flat when compared to other SIL PAD materials?**

**A:** SIL PAD 1500ST and SIL PAD 1100ST wet-out the application surfaces at a very low pressures. Optimal thermal performance is achieved at pressures as low as 50 psi.

**Q: How do I know which SIL PAD is right for my specific application?**

**A:** Each application has specific characteristics (e.g., surface finish, flatness tolerances, high pressure requirements, potential burrs, etc.) that determine which SIL PAD will optimize thermal performance. Select a minimum of two pads that best fit the application, then conduct testing to determine which material performs the best.

**Q: What is ISO9001:2008?**

**A:** The ISO certification is the adoption of a quality management system that is a strategic decision of the organization. This International Standard specifies requirements for a quality management system where an organization: a) needs to demonstrate its ability to consistently provide product that meets customer and applicable regulatory requirements, and b) aims to enhance customer satisfaction through the effective application of the system, including processes for continual improvement of the system and the assurance of conformity to customer and regulatory requirements.

## Choosing SIL PAD Thermally Conductive Insulators

### Mica and Grease

Mica insulators have been in use for over 35 years and are still commonly used as an insulator. Mica is inexpensive and has excellent dielectric strength, but it is brittle and is easily cracked or broken. Because mica used by itself has high thermal impedance, thermal grease is commonly applied to it. The grease flows easily and excludes air from the interface to reduce the interfacial thermal resistance. If the mica is also thin (2-3 mils [50-80  $\mu\text{m}$ ]), a low thermal impedance can be achieved.

However, thermal grease introduces a number of problems to the assembly process. It is time-consuming to apply, messy and difficult to clean. Once thermal grease has been applied to an electronic assembly, solder processes must be avoided to prevent contamination of the solder. Cleaning baths must also be avoided to prevent wash-out of the interface grease, causing a dry joint and contamination of the bath. Assembly, soldering and cleaning processes must be performed in one process while the greased insulators are installed off-line in a secondary process. If the grease is silicone-based, migration of silicone molecules occurs over time, drying out the grease and contaminating the assembly.

### Polyimide Films

Polyimide films can also be used as insulators and are often combined with wax or grease to achieve a low thermal impedance. These polyimide films are especially tough and have high dielectric strength. SIL PAD K-4, K-6 and K-10 incorporate polyimide film as the carrier material.

### SIL PAD Materials

SIL PAD thermally conductive insulators are designed to be clean, grease-free and flexible. The combination of a tough carrier material such as fiberglass and silicone rubber which is confirmable provides the engineer with a more versatile material than mica or ceramics and grease. SIL PAD products minimize the thermal resistance from the case of a power semiconductor to the heat sink. SIL PAD materials electrically isolate the semiconductor from the heat sink and have sufficient dielectric strength to withstand high voltage. They are also strong enough to resist puncture by the facing metal surface.

### Binders

Most SIL PAD products use silicone rubber as the binder. Silicone rubber has a low dielectric constant, high dielectric strength, good chemical resistance and high thermal stability.

Silicone rubber also exhibits cold flow, which excludes air from the interface as it conforms to the mating surfaces. This flow eliminates the need for thermal grease. A rough-surface-textured insulator needs to flow more to exclude air than a smooth one. The smoother pads also need less pressure to wet-out the surfaces and obtain optimum thermal contact.



### Carriers

The carrier provides physical reinforcement and contributes to dielectric strength. High dielectric and physical strength are obtained by using a heavy, tight mesh, but thermal resistance will suffer. A light, open mesh reduces thermal resistance, dielectric strength and cut-through resistance. The carrier materials used in SIL PAD materials include fiberglass and dielectric film.

### Fillers

The thermal conductivity of SIL PAD products is improved by filling them with ingredients of high thermal conductivity. The fillers change the characteristics of the silicone rubber to enhance thermal and/or physical characteristics.

For instance, some fillers make the silicone rubber hard and tough while still retaining the ability to flow under pressure. A harder silicone helps the material resist cut-through. In other applications, a filler is used to make the silicone rubber softer and more conformable to rough surfaces. While the range in thermal resistance of greased mica is quite large, the average is comparable to elastomeric insulators filled with a blend of the appropriate ingredients.

# SIL PAD Comparison Data

## TO-220 Thermal Performance

Q-PAD Materials  
Non-Electrically Isolating

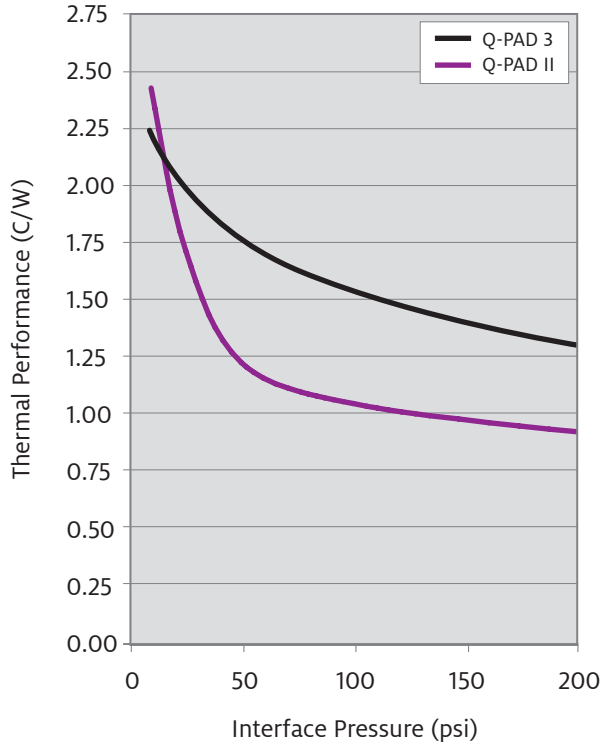

SIL PAD High Value Materials

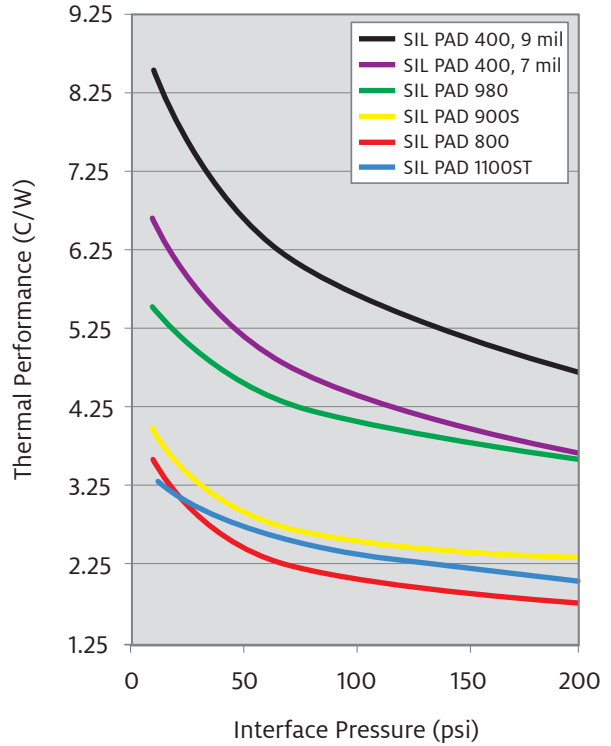

SIL PAD High Performance Materials

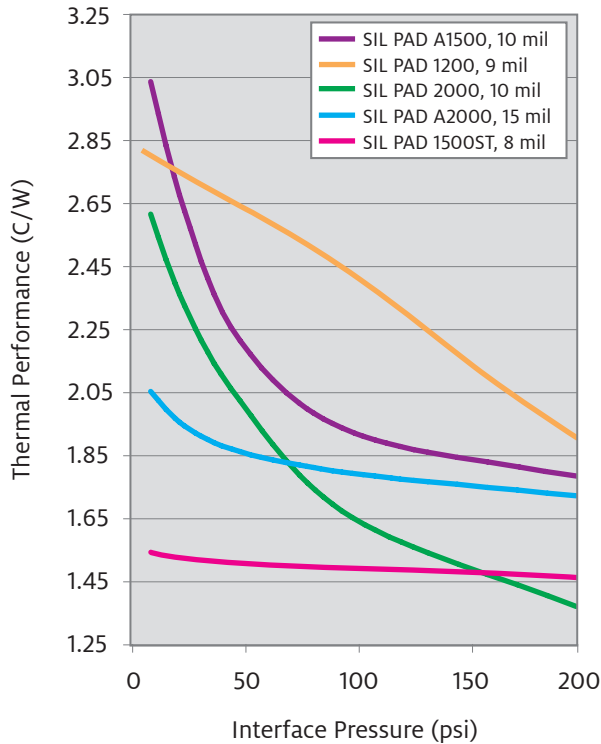

SIL PAD Polyimide-Based Materials

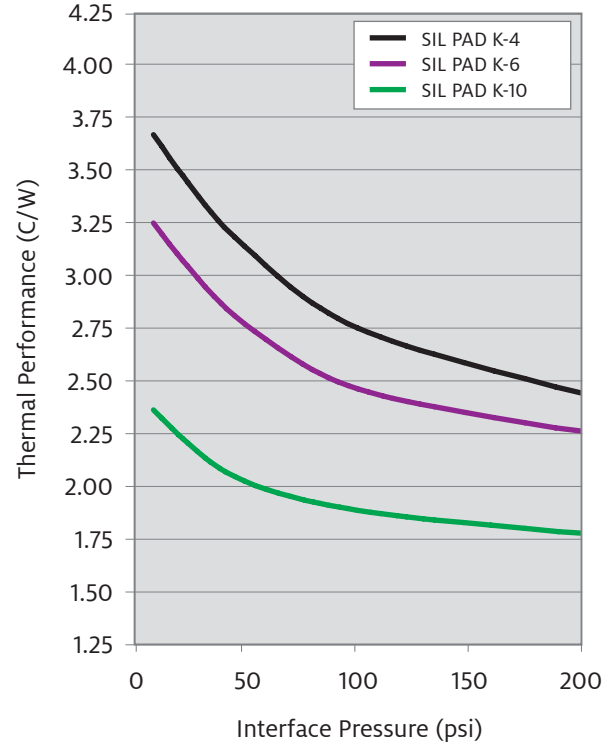

## Mechanical and Electrical Properties

### Mechanical Properties

Woven fiberglass and films are used in SIL PAD products to provide mechanical reinforcement. The most important mechanical property in SIL PAD applications is resistance to cut-through to avoid electrical shorting from the device to the heat sink.

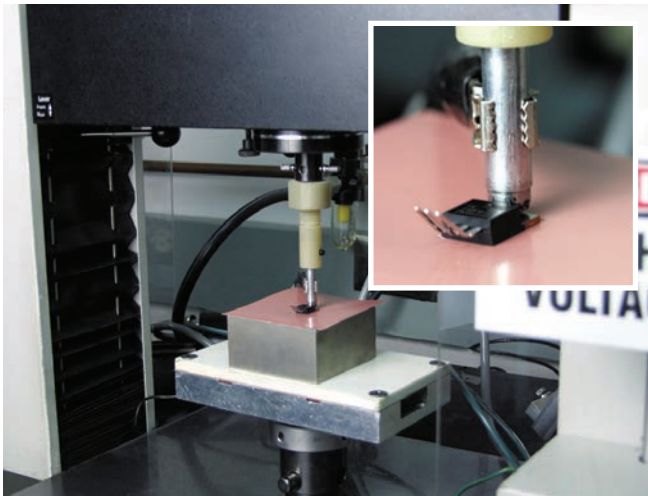

Cut-Through Resistance – The TO-220 cut-through helps customers better understand typical application performance.

### Mounting Techniques and Mounting Pressure

Typical mounting techniques include:

- A spring clip, which exerts a centralized clamping force on the body of the transistor. The greater the mounting force of the spring, the lower the thermal resistance of the insulator.
- A screw in the mounting tab. With a screw-mounted TO-220, the force on the transistor is determined by the torque applied to the fastener.

In extremely low-pressure applications, an insulator with

pressure sensitive adhesive on each side may give the lowest thermal resistance since the adhesive wets-out the interface easier than the dry rubber. This decreases the interfacial thermal resistance.

Devices with larger surface areas need more pressure to get the insulator to conform to the interface than smaller devices. In most screw-mount applications, the torque required to tighten the fastener is sufficient to generate the pressure needed for optimum thermal resistance. There are exceptions where the specified torque on the fastener does not yield the optimum thermal resistance for the insulator being used and either a different insulator or a different mounting scheme should be used.

Interfacial thermal resistance decreases as time under pressure increases. In applications where high clamping forces cannot be used, time can be substituted for pressure to achieve lower thermal resistance. The only way to know precisely what the thermal resistance of an insulator will be in an application is to measure it in that application.

### Electrical Properties

If your application does not require electrical insulation, Q-Pad II or Q-Pad 3 are ideal grease replacement materials. These materials do not provide electrical isolation but have excellent thermal properties. HI-FLOW phase change materials should also be considered for these applications. (Refer to pages 40-49 of this guide.)

The most important electrical property in a typical assembly where a SIL PAD insulator is used is dielectric strength. In many cases, the dielectric strength of a SIL PAD product will be the determining factor in the design of the apparatus in which it is to be used.

### SIL PAD TYPICAL ELECTRICAL PROPERTIES

MATERIAL	BREAKDOWN VOLTAGE	DIELECTRIC STRENGTH		DIELECTRIC CONSTANT	VOLUME RESISTIVITY
	(KV)	(VOLTS/MIL)	(KV/MM)	(1,000 HZ)	(OHMMETER)
SIL PAD 400 - 0.007	3.5	500	20	5.5	10 <sup>11</sup>
SIL PAD 400 - 0.009	4.5	500	20	5.5	10 <sup>11</sup>
SIL PAD 900S	5.5	600	24	6.0	10 <sup>10</sup>
SIL PAD 1200 - 0.009	6.0	667	26	7.0	10 <sup>10</sup>
SIL PAD A1500	6.0	600	24	7.0	10 <sup>11</sup>
SIL PAD 2000	4.0	400	16	4.0	10 <sup>11</sup>
SIL PAD K-4	6.0	1,000	39	5.0	10 <sup>12</sup>
SIL PAD K-6	6.0	1,000	39	4.0	10 <sup>12</sup>
SIL PAD K-10	6.0	1,000	39	3.7	10 <sup>12</sup>
Test Method	ASTM D149* * Method A, Type 3 Electrodes	ASTM D149* * Method A, Type 3 Electrodes		ASTM D150	ASTM D257



## Thermal Properties

SIL PAD Thermal Performance Overview (TO-220 Test @ 50 psi)

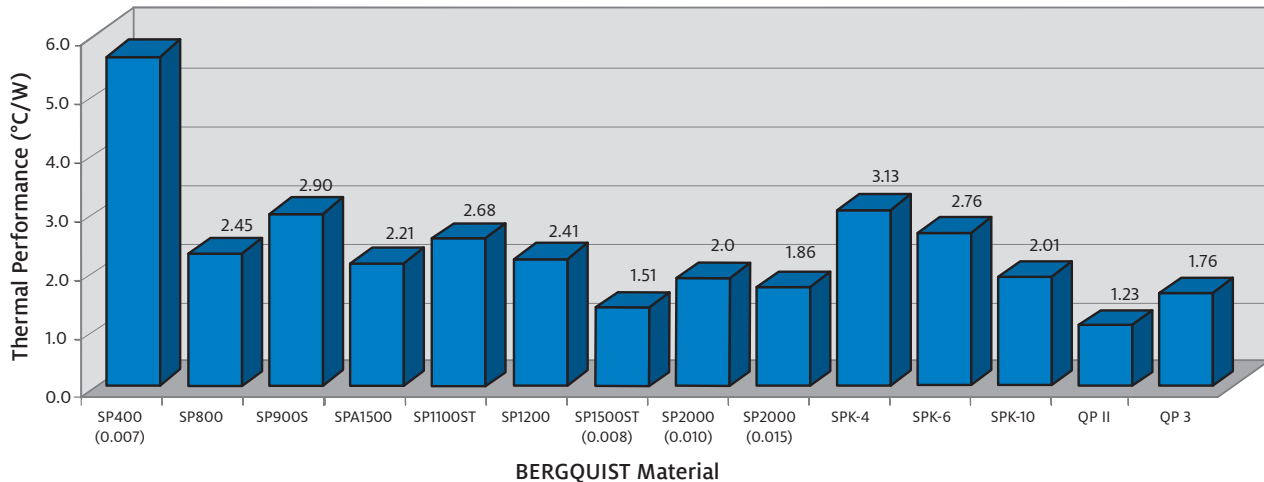

Here are some general guidelines regarding electrical properties to consider when selecting a SIL PAD material:

- Q-Pad II and Q-Pad 3 are used when electrical isolation is not required.
- Dielectric breakdown voltage is the total voltage that a dielectric material can withstand. When insulating electrical components from each other and ground, it is desirable to use an insulator with a high breakdown voltage.
- Breakdown voltage decreases as the area of the electrodes increases. This area effect is more pronounced as the thickness of the insulator decreases.
- Breakdown voltage decreases as temperature increases.
- Breakdown voltage decreases as humidity increases.
- Breakdown voltage decreases in the presence of partial discharge.
- Breakdown voltage decreases as the size of the voltage source (kVA rating) increases.
- Breakdown voltage can be decreased by excessive mechanical stress on the insulator.

Dielectric strength, dielectric constant and volume resistivity should all be taken into consideration when selecting a SIL PAD material. If your application requires specific electrical performance, please contact a Henkel Sales Representative for more detailed testing information.

### Thermal Properties

The thermal properties of a SIL PAD material and your requirements for thermal performance probably have more to do with your selection of a SIL PAD product than any other factor.

Discrete semiconductors, under normal operating conditions, dissipate waste power which raises the junction temperature of the device. Unless sufficient heat is conducted out of the device, its electrical performance and parameters are changed. A 10°C

rise in junction temperature can reduce the mean-time-to-failure of a device by a factor of two. Also, above 25°C, the semiconductor's total power handling capability will be reduced by a derating factor inherent to the device.

The thermal properties of SIL PAD products are thermal impedance, thermal conductivity and thermal resistance. The thermal resistance and conductivity of SIL PAD products are inherent to the material and do not change. Thermal resistance and thermal conductivity are measured per ASTM D5470 and do not include the interfacial thermal resistance effects. Thermal impedance applies to the thermal transfer in an application and includes the effects of interfacial thermal resistance. As the material is applied in different ways, the thermal impedance values will vary from application to application.

- The original SIL PAD material, SIL PAD 400, continues to be the BERGQUIST brand's most popular material for many applications.
- SIL PAD A1500 is chosen when greater thermal performance is required. SIL PAD A2000 is ideal for high performance, high reliability applications.

Beyond these standard materials, many things can contribute to the selection of the correct material for a particular application. Questions regarding the amount of torque and clamping pressure are often asked when selecting a SIL PAD material. Here are some guidelines:

- Interfacial thermal resistance decreases as clamping pressure increases.
- The clamping pressure required to minimize interfacial thermal resistance can vary with each type of insulator.
- SIL PAD products with smooth surface finishes (SIL PAD A1500, SIL PAD A2000, SIL PAD K-4, SIL PAD K-6 and SIL PAD K-10) are less sensitive to clamping pressure than SIL PAD materials with rough surface finishes (SIL PAD 400) or smooth and tacky finishes (SIL PAD 1500ST).



## SIL PAD Thermally Conductive Insulator Selection Table

	SIL PAD 400 .007 IN.	SIL PAD 400 .009 IN.	SIL PAD 800	SIL PAD 900S	SIL PAD 980	SIL PAD 1100ST	SIL PAD 1200	SIL PAD A1500	TEST METHOD
COLOR	GREY	GREY	GOLD	PINK	MAUVE	YELLOW	BLACK	GREEN	VISUAL
Thickness (in./mm)	.007 ± .001 (.18 ± .025)	.009 ± .001 (.23 ± .025)	.005 ± .001 (.13 ± .025)	.009 ± .001 (.23 ± .025)	.009 ± .001 (.23 ± .025)	.012 ± .001 (.30 ± .025)	.009 ± .001 (.23 ± .025)	.010 ± .001 (.25 ± .025)	ASTM D374
Thermal Performance TO-220 Test @ 50 psi °C/W	5.14	6.61	2.45	2.90	4.52	2.68	2.41	2.21	ASTM D5470
Thermal Impedance (°C-in. <sup>2</sup> /W)	1.13	1.45	0.53	0.61	1.07	0.81	0.53	0.42	ASTM D5470
Thermal Conductivity (W/m-K nominal)	0.9	0.9	1.6	1.6	1.2	1.1	1.8	2.0	ASTM D5470
Voltage Breakdown (Vac.)	3,500	4,500	2,000	5,500	4,000	5,000	6,000	6,000	ASTM D149
Continuous Use Temperature (°C)	-60 to 180	-60 to 180	-60 to 180	-60 to 180	-40 to 150	-60 to 180	-60 to 180	-60 to 180	—
Construction	Silicone/ Fiberglass	Silicone/ Fiberglass	Silicone/ Fiberglass	Silicone/ Fiberglass	Silicone/ Fiberglass	Silicone/ Fiberglass	Silicone/ Fiberglass	Silicone/ Fiberglass	—

### SIL PAD Applications

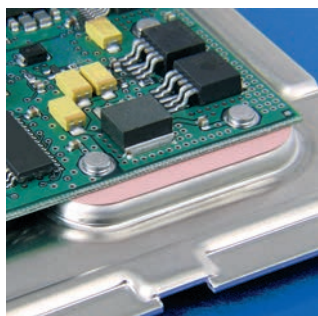

Here, SIL PAD 900S enhances the thermal transfer from this FR-4 circuit board with thermal vias to the metal base plate.



SIL PAD is available in over 100 standard configurations for common JEDEC package outlines.

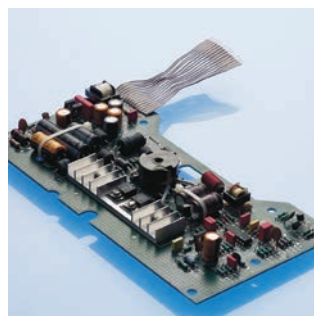

The circuit board above shows punched parts interfacing screw-mounted transistors to a finned heat sink.

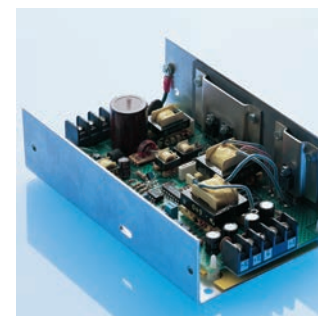

This application uses SIL PAD to isolate the mounting brackets from the assembly frame.

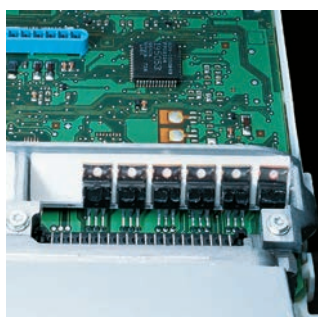

A common SIL PAD application includes TO-220 transistors mounted in a row on a heat rail.

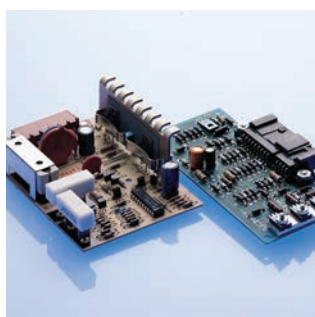

These SIL PAD applications show clip mounting of transistors on the left and screw mounting to an aluminum bracket on the right.

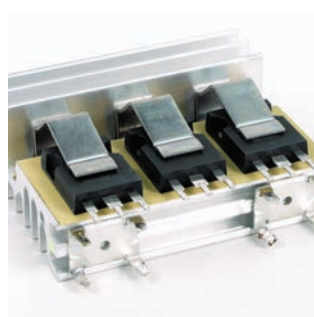

Choose a SIL PAD that optimizes thermal performance for your mounting method — screw, clip, spring, bar, etc.



SIL PAD 980 is used extensively in industrial applications having excellent cut-through and abrasion resistance.

# SIL PAD Thermally Conductive Insulator Selection Table

	SIL PAD 1500ST	SIL PAD 2000	SIL PAD A2000	SIL PAD K-4	SIL PAD K-6	SIL PAD K-10	POLY-PAD 1000	POLY-PAD K-4	POLY-PAD K-10	TEST METHOD
COLOR	BLUE	WHITE	WHITE	GREY	BLUE-GREEN	BEIGE	YELLOW	TAN	YELLOW	VISUAL
Thickness (in./mm)	.008 ± .001 (.20 ± .025)	.010 ± .001 (.25 ± .025)	.015 ± .001 (.38 ± .025)	.006 ± .001 (.15 ± .025)	.006 ± .001 (.15 ± .025)	.006 ± .001 (.15 ± .025)	.009 ± .001 (.23 ± .025)	.006 ± .001 (.15 ± .025)	.006 ± .001 (.15 ± .025)	ASTM D374
Thermal Performance TO-220 Test @ 50 psi °C/W	1.51	2.02	1.86	3.13	2.76	2.01	3.74	4.34	2.75	ASTM D5470
Thermal Impedance (°C-in. <sup>2</sup> /W)	0.23	0.33	0.32	0.62	0.64	0.41	0.82	0.95	0.60	ASTM D5470
Thermal Conductivity (W/m-K nominal)	1.8	3.5	3.0	0.9	1.1	1.3	1.2	0.9	1.3	ASTM D5470
Voltage Breakdown (Vac.)	3,000	4,000	4,000	6,000	6,000	6,000	1,300	5,500	6,000	ASTM D149
Continuous Use Temperature (°C)	-60 to 180	-60 to 200	-60 to 200	-60 to 180	-60 to 180	-60 to 180	-20 to 150	-20 to 150	-20 to 150	—
Construction	Silicone/ Fiberglass	Silicone/ Fiberglass	Silicone/ Fiberglass	Silicone/Film	Silicone/Film	Silicone/Film	Polyester/ Fiberglass	Polyester/ Film	Polyester/Film	—

## SIL PAD Comparison Made Simple

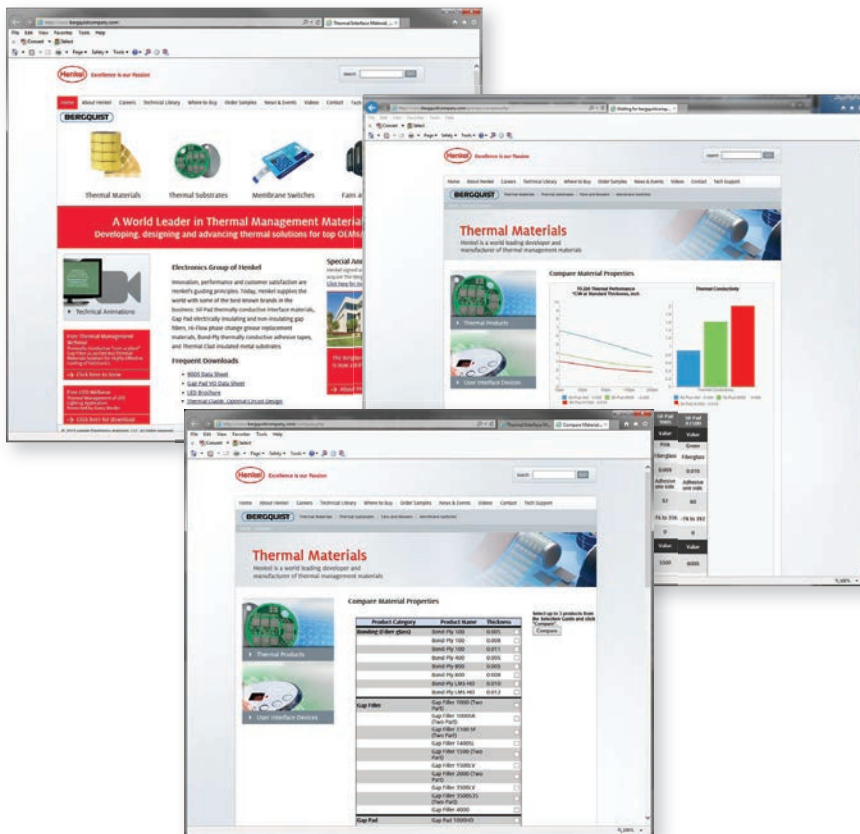

*Comparing thermally conductive interface materials has never been easier.*

Simply go to the “Thermal Materials” section of our website [www.henkel-adhesives.com/thermal](http://www.henkel-adhesives.com/thermal) and select “Compare Material Properties.” Then select up to three separate products and this handy comparison tool will automatically chart thermal resistance values and display a material properties table of the selected materials.

The materials comparison tool can be used for most BERGQUIST thermal materials, including SIL PAD, HI-FLOW, GAP PAD, Q-PAD, BOND-PLY and LIQUI-BOND.

# SIL PAD 400

## The Original SIL PAD Material

### Features and Benefits

- Thermal impedance: 1.13°C-in.<sup>2</sup>/W (@ 50 psi)
- Original SIL PAD material
- Excellent mechanical and physical characteristics
- Flame retardant



SIL PAD 400 is a composite of silicone rubber and fiberglass. The material is flame retardant and is specially formulated for use as a thermally conductive insulator. The primary use for SIL PAD 400 is to electrically isolate power sources from heat sinks.

SIL PAD 400 has excellent mechanical and physical characteristics. Surfaces are pliable and allow complete surface contact with excellent heat dissipation. SIL PAD 400 actually improves its thermal resistance with age. The reinforcing fiberglass provides excellent cut-through resistance. In addition, SIL PAD 400 is nontoxic and resists damage from cleaning agents.

### TYPICAL PROPERTIES OF SIL PAD 400

PROPERTY	IMPERIAL VALUE	METRIC VALUE	TEST METHOD			
Color	Grey	Grey	Visual			
Reinforcement Carrier	Fiberglass	Fiberglass	—			
Thickness (in.) / (mm)	0.007, 0.009	0.178, 0.229	ASTM D374			
Hardness (Shore A)	85	85	ASTM D2240			
Breaking Strength (lbs./in.) / (kN/m)	30	5	ASTM D1458			
Elongation (% at 45° to Warp and Fill)	54	54	ASTM D412			
Tensile Strength (psi) / (mPa)	3,000	20	ASTM D412			
Continuous Use Temp. (°F) / (°C)	-76 to 356	-60 to 180	—			
<b>ELECTRICAL</b>						
Dielectric Breakdown Voltage (Vac.)	3,500, 4,500	3,500, 4,500	ASTM D149			
Dielectric Constant (1,000 Hz)	5.5	5.5	ASTM D150			
Volume Resistivity (Ohmmeter)	10 <sup>11</sup>	10 <sup>11</sup>	ASTM D257			
Flame Rating	V-0	V-0	UL 94			
<b>THERMAL</b>						
Thermal Conductivity (W/m-K)	0.9	0.9	ASTM D5470			
<b>THERMAL PERFORMANCE VS. PRESSURE</b>						
	Pressure (psi)	10	25	50	100	200
TO-220 Thermal Performance (°C/W) 0.007 in.		6.62	5.93	5.14	4.38	3.61
TO-220 Thermal Performance (°C/W) 0.009 in.		8.51	7.62	6.61	5.63	4.64
Thermal Impedance (°C-in. <sup>2</sup> /W) 0.007 in. <sup>(1)</sup>		1.82	1.42	1.13	0.82	0.54
Thermal Impedance (°C-in. <sup>2</sup> /W) 0.009 in. <sup>(1)</sup>		2.34	1.83	1.45	1.05	0.69

1) The ASTM D5470 test fixture was used. The recorded value includes interfacial thermal resistance. These values are provided for reference only. Actual application performance is directly related to the surface roughness, flatness and pressure applied.

### Typical Applications Include:

- Power supplies
- Power semiconductors
- Automotive electronics
- Motor controls

### Configurations Available:

- Sheet form, die-cut parts and roll form; with or without pressure sensitive adhesive

### Building a Part Number

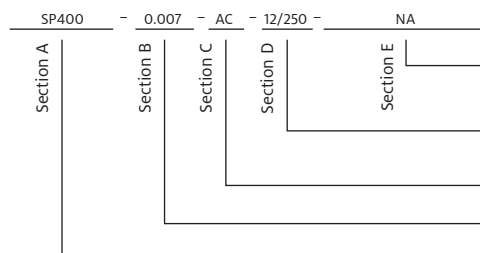

### Standard Options

◀ example

NA = Selected standard option. If not selecting a standard option, insert company name, drawing number, and revision level.

\_\_\_ = Standard configuration dash number, 1212 = 12" x 12" sheets, 12/250 = 12" x 250-foot rolls, or 00 = custom configuration

AC = Adhesive, one side; or 00 = no adhesive

Standard thicknesses available: 0.007", 0.009"

SP400 = SIL-PAD 400 Material

Note: To build a part number, go to [www.bergquistcompany.com/Part\\_Number\\_Builder.php](http://www.bergquistcompany.com/Part_Number_Builder.php).

# SIL PAD 800

## High Performance Insulator for Low-Pressure Applications

### Features and Benefits

- Thermal impedance: 0.45°C-in.<sup>2</sup>/W (@ 50 psi)
- High value material
- Smooth and highly compliant surface
- Electrically isolating

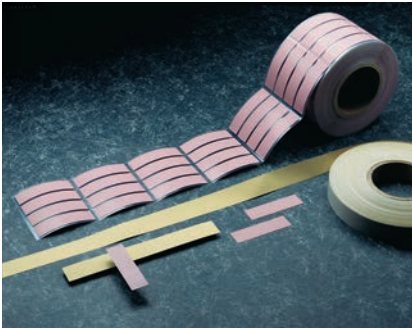

The SIL PAD 800 family of thermally conductive insulation materials is designed for applications requiring high thermal performance and electrical isolation. These applications also typically have low mounting pressures for component clamping.

SIL PAD 800 material combines a smooth and highly compliant surface characteristic with high thermal conductivity. These features optimize the thermal resistance properties at low pressure.

Applications requiring low component clamping forces include discrete semiconductors (TO-220, TO-247 and TO-218) mounted with spring clips. Spring clips assist with quick assembly but apply a limited amount of force to the semiconductor. The smooth surface texture of SIL PAD 800 minimizes interfacial thermal resistance and maximizes thermal performance.

### TYPICAL PROPERTIES OF SIL PAD 800

PROPERTY	IMPERIAL VALUE	METRIC VALUE	TEST METHOD			
Color	Gold	Gold	Visual			
Reinforcement Carrier	Fiberglass	Fiberglass	—			
Thickness (in.) / (mm)	0.005	0.127	ASTM D374			
Hardness (Shore A)	91	91	ASTM D2240			
Elongation (% at 45° to Warp and Fill)	20	20	ASTM D412			
Tensile Strength (psi) / (mPa)	1,700	12	ASTM D412			
Continuous Use Temp. (°F) / (°C)	-76 to 356	-60 to 180	—			
<b>ELECTRICAL</b>						
Dielectric Breakdown Voltage (Vac.)	3,000	3,000	ASTM D149			
Dielectric Constant (1,000 Hz)	6.0	6.0	ASTM D150			
Volume Resistivity (Ohmmeter)	10 <sup>10</sup>	10 <sup>10</sup>	ASTM D257			
Flame Rating	V-O	V-O	UL 94			
<b>THERMAL</b>						
Thermal Conductivity (W/m-K)	1.6	1.6	ASTM D5470			
<b>THERMAL PERFORMANCE VS. PRESSURE</b>						
	Pressure (psi)	10	25	50	100	200
	TO-220 Thermal Performance (°C/W)	3.56	3.01	2.45	2.05	1.74
	Thermal Impedance (°C-in. <sup>2</sup> /W) <sup>(1)</sup>	0.92	0.60	0.45	0.36	0.29

1) The ASTM D5470 test fixture was used. The recorded value includes interfacial thermal resistance. These values are provided for reference only. Actual application performance is directly related to the surface roughness, flatness and pressure applied.

### Typical Applications Include:

- Power supplies
- Automotive electronics
- Motor controls
- Power semiconductors

### Configurations Available:

- Sheet form, die-cut parts and roll form
- With or without pressure sensitive adhesive

### Building a Part Number

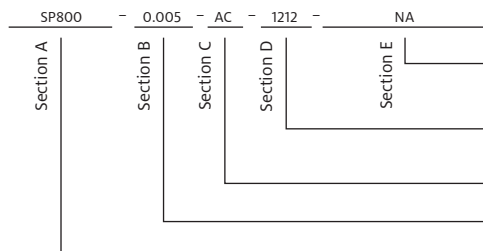

### Standard Options

#### ◀ example

NA = Selected standard option. If not selecting a standard option, insert company name, drawing number, and revision level.

\_\_\_ = Standard configuration dash number,  
1212 = 12" x 12" sheets, 12/250 = 12" x 250-foot rolls, or  
00 = custom configuration

AC = Adhesive, one side  
00 = No adhesive

Standard thicknesses available: 0.005"

SP800 = SIL-PAD 800 Material

Note: To build a part number, go to [www.bergquistcompany.com/Part\\_Number\\_Builder.php](http://www.bergquistcompany.com/Part_Number_Builder.php).



## SIL PAD 900S

## High Performance Insulator for Low-Pressure Applications

## Features and Benefits

- Thermal impedance: 0.61°C-in.<sup>2</sup>/W (@ 50 psi)
- Electrically isolating
- Low mounting pressures
- Smooth and highly compliant surface
- General-purpose thermal interface material solution

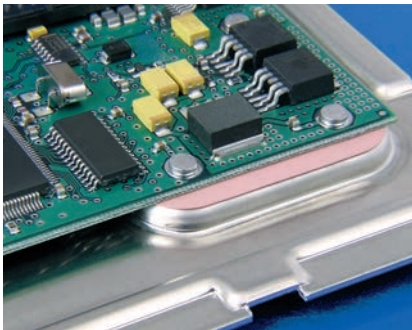

The true workhorse of the SIL PAD product family, SIL PAD 900S thermally conductive insulation material is designed for a wide variety of applications requiring high thermal performance and electrical isolation. These applications also typically have low mounting pressures for component clamping.

SIL PAD 900S material combines a smooth and highly compliant surface characteristic with high thermal conductivity. These features optimize the thermal resistance properties at low pressures.

Applications requiring low component clamping forces include discrete semiconductors (TO-220, TO-247 and TO-218) mounted with spring clips. Spring clips assist with quick assembly and apply a limited amount of force to the semiconductor. The smooth surface texture of SIL PAD 900S minimizes interfacial thermal resistance and maximizes thermal performance.

## TYPICAL PROPERTIES OF SIL PAD 900S

PROPERTY	IMPERIAL VALUE	METRIC VALUE	TEST METHOD			
Color	Pink	Pink	Visual			
Reinforcement Carrier	Fiberglass	Fiberglass	—			
Thickness (in.) / (mm)	0.009	0.229	ASTM D374			
Hardness (Shore A)	92	92	ASTM D2240			
Elongation (% at 45° to Warp and Fill)	20	20	ASTM D412			
Tensile Strength (psi) / (mPa)	1,300	9	ASTM D412			
Continuous Use Temp. (°F) / (°C)	-76 to 356	-60 to 180	—			
<b>ELECTRICAL</b>						
Dielectric Breakdown Voltage (Vac.)	5,500	5,500	ASTM D149			
Dielectric Constant (1,000 Hz)	6.0	6.0	ASTM D150			
Volume Resistivity (Ohmmeter)	10 <sup>10</sup>	10 <sup>10</sup>	ASTM D257			
Flame Rating	V-0	V-0	UL 94			
<b>THERMAL</b>						
Thermal Conductivity (W/m-K)	1.6	1.6	ASTM D5470			
<b>THERMAL PERFORMANCE VS. PRESSURE</b>						
	Pressure (psi)	10	25	50	100	200
	TO-220 Thermal Performance (°C/W)	3.96	3.41	2.90	2.53	2.32
	Thermal Impedance (°C-in. <sup>2</sup> /W) <sup>(1)</sup>	0.95	0.75	0.61	0.47	0.41

1) The ASTM D5470 test fixture was used. The recorded value includes interfacial thermal resistance. These values are provided for reference only. Actual application performance is directly related to the surface roughness, flatness and pressure applied.

## Typical Applications Include:

- Power supplies
- Automotive electronics
- Motor controls
- Power semiconductors

## Configurations Available:

- Sheet form, die-cut parts and roll form
- With or without pressure sensitive adhesive

## Building a Part Number

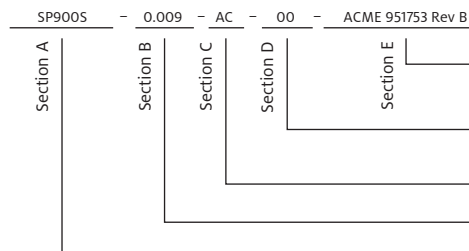

## Standard Options

◀ example

NA = Selected standard option. If not selecting a standard option, insert company name, drawing number, and revision level.

\_\_\_ = Standard configuration dash number, 1212 = 12" x 12" sheets, 12/250 = 12" x 250-foot rolls, or 00 = custom configuration

AC = Adhesive, one side  
00 = No adhesive

Standard thicknesses available: 0.009"

SP900S = SIL-PAD 900S Material

Note: To build a part number, go to [www.bergquistcompany.com/Part\\_Number\\_Builder.php](http://www.bergquistcompany.com/Part_Number_Builder.php).

# SIL PAD 980

## High Cut-Through Resistant, Electrically Insulating, Thermally Conductive Material

### Features and Benefits

- Thermal impedance: 1.07°C-in.<sup>2</sup>/W (@ 50 psi)
- Excellent cut-through resistance
- Use in screw-mounted applications with cut-through problems



In addition to excellent heat transfer and dielectric properties, SIL PAD 980 is specially formulated for high resistance to crushing and cut-through typically found in high-pressure applications where surface imperfections such as burrs and dents are inherently common (e.g., heavily-machined metal surfaces manufactured from extrusions or castings).

With a field-proven history of reliability, SIL PAD 980 is Henkel's best material for cut-through resistance in screw-mounted and other applications with cut-through problems.

### TYPICAL PROPERTIES OF SIL PAD 980

PROPERTY	IMPERIAL VALUE	METRIC VALUE	TEST METHOD			
Color	Mauve	Mauve	Visual			
Reinforcement Carrier	Fiberglass	Fiberglass	—			
Thickness (in.) / (mm)	0.009	0.229	ASTM D374			
Hardness (Shore A)	95	95	ASTM D2240			
Breaking Strength (lbs./in.) / (kN/m)	140	26	ASTM D1458			
Elongation (% at 45° to Warp and Fill)	10	10	ASTM D412			
Cut-Through (lbs.) / (kg)	750	340	ASTM D412			
Continuous Use Temp. (°F) / (°C)	-40 to 302	-40 to 150	—			
<b>ELECTRICAL</b>						
Dielectric Breakdown Voltage (Vac.)	4,000	4,000	ASTM D149			
Dielectric Constant (1,000 Hz)	6.0	6.0	ASTM D150			
Volume Resistivity (Ohmmeter)	10 <sup>10</sup>	10 <sup>10</sup>	ASTM D257			
Flame Rating	V-0	V-0	UL 94			
<b>THERMAL</b>						
Thermal Conductivity (W/m-K)	1.2	1.2	ASTM D5470			
<b>THERMAL PERFORMANCE VS. PRESSURE</b>						
	Pressure (psi)	10	25	50	100	200
	TO-220 Thermal Performance (°C/W)	5.48	5.07	4.52	4.04	3.56
	Thermal Impedance (°C-in. <sup>2</sup> /W) <sup>1)</sup>	1.51	1.22	1.07	0.89	0.53
1) The ASTM D5470 test fixture was used. The recorded value includes interfacial thermal resistance. These values are provided for reference only. Actual application performance is directly related to the surface roughness, flatness and pressure applied.						

### Typical Applications Include:

- Silicone-sensitive assemblies
- Telecommunications
- Automotive electronics

### Configurations Available:

- Sheet form, die-cut parts and roll form
- With or without pressure sensitive adhesive

### Building a Part Number

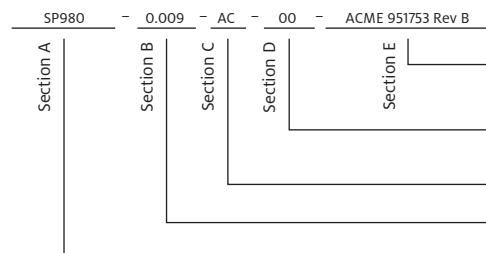

### Standard Options

#### ◀ example

NA = Selected standard option. If not selecting a standard option, insert company name, drawing number, and revision level.

\_\_\_ = Standard configuration dash number, 1212 = 12" x 12" sheets, 12/250 = 12" x 250-foot rolls, or 00 = custom configuration

AC = Adhesive, one side  
00 = No adhesive

Standard thicknesses available: 0.009"

SP980 = SIL-PAD 980 Material

Note: To build a part number, go to [www.bergquistcompany.com/Part\\_Number\\_Builder.php](http://www.bergquistcompany.com/Part_Number_Builder.php).



# SIL PAD 1100ST

Affordable, Electrically Insulating, Thermally Conductive, Soft Tack Elastomeric Material

## Features and Benefits

- Inherent tack on both sides for exceptional thermal performance and easy placement
- Repositionable for higher utilization, ease of use and assembly error reduction
- Lined on both sides for ease of handling prior to placement in high volume assemblies
- Exhibits exceptional thermal performance even at a low mounting pressure
- Fiberglass-reinforced
- Value alternative to SIL PAD 1500ST



SIL PAD 1100ST (Soft Tack) is a fiberglass-reinforced thermal interface material featuring inherent tack on both sides. The material exhibits excellent thermal performance at low mounting pressures. The material is supplied on two liners for exceptionally easy handling prior to auto-placement in high volume assemblies. The material is ideal for placement between an electronic power device and its heat sink.

## TYPICAL PROPERTIES OF SIL PAD 1100ST

PROPERTY	IMPERIAL VALUE	METRIC VALUE	TEST METHOD			
Color	Yellow	Yellow	Visual			
Reinforcement Carrier	Fiberglass	Fiberglass	—			
Thickness (in.) / (mm)	0.012	0.305	ASTM D374			
Inherent Surface Tack (1- or 2-sided)	2	2	—			
Hardness (Shore 00) <sup>(1)</sup>	85	85	ASTM D2240			
Breaking Strength (lb./in.) / (kN/m)	2.6	0.5	ASTM D1458			
Elongation (% at 45° to Warp and Fill)	16	16	ASTM D412			
Tensile Strength (psi) / (mPa)	220	1.5	ASTM D412			
Continuous Use Temp. (°F) / (°C)	-76 to 356	-60 to 180	—			
<b>ELECTRICAL</b>						
Dielectric Breakdown Voltage (Vac.)	5,000	5,000	ASTM D149			
Dielectric Constant (1,000 Hz)	5.0	5.0	ASTM D150			
Volume Resistivity (Ohmmeter)	10 <sup>10</sup>	10 <sup>10</sup>	ASTM D257			
Flame Rating	V-0	V-0	UL 94			
<b>THERMAL</b>						
Thermal Conductivity (W/m-K)	1.1	1.1	ASTM D5470			
<b>THERMAL PERFORMANCE VS. PRESSURE</b>						
	Pressure (psi)	10	25	50	100	200
	TO-220 Thermal Performance (°C/W)	2.72	2.71	2.68	2.62	2.23
	Thermal Impedance (°C-in. <sup>2</sup> /W) <sup>(2)</sup>	0.75	0.71	0.66	0.61	0.57
<small>1) Thirty-second delay value Shore 00 hardness scale.            2) The ASTM D5470 test fixture was used. The recorded value includes interfacial thermal resistance. These values are provided for reference only. Actual application performance is directly related to the surface roughness, flatness and pressure applied.</small>						

## Typical Applications Include:

- Automotive ECMS
- Power supplies
- Motor controls
- Between an electronic power device and its heat sink

## Configurations Available:

- Sheet form, die-cut parts and roll form
- Top and bottom liners

## Building a Part Number

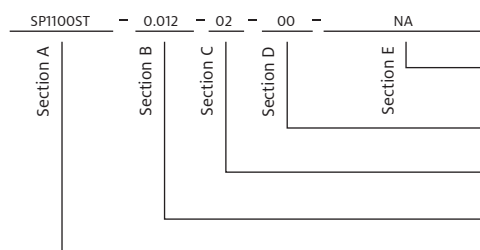

## Standard Options

◀ example

NA = Selected standard option. If not selecting a standard option, insert company name, drawing number, and revision level.

1212 = 12" x 12" sheets, 12/250 = 12" x 250-foot rolls or 00 = custom configuration

02 = Natural tack, both sides

Standard thicknesses available: 0.012"

SP1100ST = SIL-PAD 1100ST Material

Note: To build a part number, go to [www.bergquistcompany.com/Part\\_Number\\_Builder.php](http://www.bergquistcompany.com/Part_Number_Builder.php).

# SIL PAD 1200

## Exceptional Performance, Thermally Conductive Elastomeric Material

### Features and Benefits

- Thermal Impedance: 0.53°C-in.<sup>2</sup>/W (@ 50 psi)
- Exceptional thermal performance at lower application pressures
- Smooth and non-tacky on both sides for easy repositioning, ease of use and assembly error reduction
- Exceptional breakdown voltage and surface “wet-out” values
- Designed for applications where electrical isolation is critical
- Excellent cut-through resistance, designed for screw and clip mounted applications

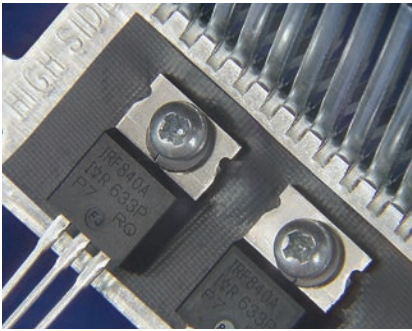

SIL PAD 1200 is a silicone-based, fiberglass-reinforced thermal interface material featuring a smooth, highly compliant surface. The material features a non-tacky surface for efficient repositioning and ease of use, as well as an optional adhesive coating. SIL PAD 1200 exhibits exceptional thermal performance at low and high application pressures. The material is ideal for placement between electronic power devices and a heat sink for screw and clip mounted applications.

### TYPICAL PROPERTIES OF SIL PAD 1200

PROPERTY	IMPERIAL VALUE	METRIC VALUE	TEST METHOD			
Color	Black	Black	Visual			
Reinforcement Carrier	Fiberglass	Fiberglass	—			
Thickness (in.) / (mm)	0.009 to 0.016	0.229 to 0.406	ASTM D374			
Hardness Bulk Rubber (Shore 00)	80	80	ASTM D2240			
Elongation (% at 45° to warp and fill)	20	20	ASTM D412			
Tensile Strength (psi) / (mPa)	1300	9	ASTM D412			
Continuous Use Temp. (°F) / (°C)	-76 to 356	-60 to 180	—			
<b>ELECTRICAL</b>						
Dielectric Breakdown Voltage (Vac.)	6,000	6,000	ASTM D149			
Dielectric Constant (1,000 Hz)	8.0	8.0	ASTM D150			
Volume Resistivity (Ohmmeter)	10 <sup>9</sup>	10 <sup>9</sup>	ASTM D257			
Flame Rating	V-O	V-O	UL 94			
<b>THERMAL</b>						
Thermal Conductivity (W/m-K) <sup>(1)</sup>	1.8	1.8	ASTM D5470			
<b>THERMAL PERFORMANCE VS. PRESSURE</b>						
	Pressure (psi)	10	25	50	100	200
	TO-220 Thermal Performance (°C/W)	2.82	2.64	2.41	2.13	1.90
	Thermal Impedance (°C-in. <sup>2</sup> /W) <sup>(2)</sup>	0.71	0.62	0.53	0.47	0.41

1) This is the measured thermal conductivity of the SIL PAD Compound.  
2) The ASTM D5470 test fixture was used. The recorded value includes interfacial thermal resistance. These values are provided for reference only. Actual application performance is directly related to the surface roughness, flatness and pressure applied.

### Typical Applications Include:

- Automotive electronics control modules
- Motor controls
- Discrete devices
- Power supplies
- Audio amplifiers
- Telecommunications

### Configurations Available:

- Sheet form, slit-to-width roll form
- Die-cut parts
- 9, 12 and 16 mil thicknesses
- Adhesive coating

We produce thousands of specials and customs. Tooling charges vary depending on tolerances and complexity of the part.

### Building a Part Number

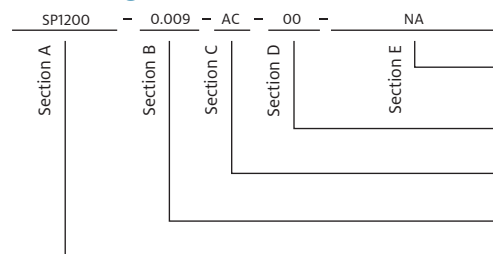

### Standard Options

#### ◀ example

NA = Selected standard option. If not selecting a standard option, insert company name, drawing number, and revision level.

— = Standard configuration dash number, 1212 = 12" x 12" sheets, 12/250 = 12-foot x 250 in. or 00 = custom configuration

AC = Adhesive, one side  
00 = No adhesive

Standard thicknesses available: 0.009", 0.012", 0.016"

SP1200 = SIL-PAD 1200 Material

Note: To build a part number, go to [www.bergquistcompany.com/Part\\_Number\\_Builder.php](http://www.bergquistcompany.com/Part_Number_Builder.php).

## SIL PAD A1500

## Electrically Insulating, Thermally Conductive Elastomeric Material

## Features and Benefits

- Thermal impedance: 0.42°C-in.<sup>2</sup>/W (@ 50 psi)
- Elastomeric compound coated on both sides

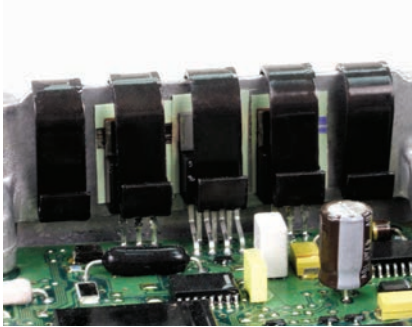

SIL PAD A1500 is a silicone-based, thermally conductive and electrically insulating material. It consists of a cured silicone elastomeric compound coated on both sides of a fiberglass reinforcement layer.

SIL PAD A1500 performs well under clamping pressure up to 200 psi and is an excellent choice for high performance applications requiring electrical isolation and cut-through resistance.

## TYPICAL PROPERTIES OF SIL PAD A1500

PROPERTY	IMPERIAL VALUE	METRIC VALUE	TEST METHOD			
Color	Green	Green	Visual			
Reinforcement Carrier	Fiberglass	Fiberglass	—			
Thickness (in.) / (mm)	0.010	0.254	ASTM D374			
Hardness (Shore A)	80	80	ASTM D2240			
Breaking Strength (lbs./in.) / (kN/m)	65	12	ASTM D1458			
Elongation (% at 45° to Warp and Fill)	40	40	ASTM D412			
Continuous Use Temp. (°F) / (°C)	-76 to 356	-60 to 180	—			
<b>ELECTRICAL</b>						
Dielectric Breakdown Voltage (Vac.)	6,000	6,000	ASTM D149			
Dielectric Constant (1,000 Hz)	7.0	7.0	ASTM D150			
Volume Resistivity (Ohmmeter)	10 <sup>11</sup>	10 <sup>11</sup>	ASTM D257			
Flame Rating	V-O	V-O	UL 94			
<b>THERMAL</b>						
Thermal Conductivity (W/m-K)	2.0	2.0	ASTM D5470			
<b>THERMAL PERFORMANCE VS. PRESSURE</b>						
	Pressure (psi)	10	25	50	100	200
	TO-220 Thermal Performance (°C/W)	3.03	2.62	2.21	1.92	1.78
	Thermal Impedance (°C-in. <sup>2</sup> /W) <sup>(1)</sup>	0.59	0.50	0.42	0.34	0.31

1) The ASTM D5470 test fixture was used. The recorded value includes interfacial thermal resistance. These values are provided for reference only. Actual application performance is directly related to the surface roughness, flatness and pressure applied.

## Typical Applications Include:

- Power supplies
- Automotive electronics
- Motor controls
- Power semiconductors

## Configurations Available:

- Sheet form, die-cut parts, and roll form
- With or without pressure sensitive adhesive

## Building a Part Number

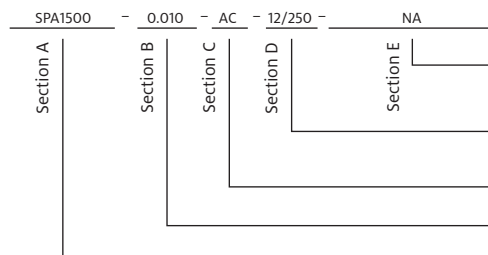

## Standard Options

◀ example

NA = Selected standard option. If not selecting a standard option, insert company name, drawing number, and revision level.

\_\_\_ = Standard configuration dash number, 1212 = 12" x 12" sheets, 12/250 = 12" x 250' rolls, or 00 = custom configuration

AC = Adhesive, one side  
00 = No adhesive

Standard thicknesses available: 0.010"

SPA1500 = SIL-PAD A1500 Material

Note: To build a part number, go to [www.bergquistcompany.com/Part\\_Number\\_Builder.php](http://www.bergquistcompany.com/Part_Number_Builder.php).

# SIL PAD 1500ST

## Electrically Insulating, Thermally Conductive, Soft Tack Elastomeric Material

### Features and Benefits

- Thermal impedance: 0.23°C-in.<sup>2</sup>/W (@ 50 psi)
- Naturally tacky on both sides
- Pad is repositionable
- Excellent thermal performance
- Auto-placement and dispensable



SIL PAD 1500ST (Soft Tack) is a fiberglass-reinforced thermal interface material that is naturally tacky on both sides. SIL PAD 1500ST exhibits exceptional thermal performance.

SIL PAD 1500ST is supplied in sheet or roll form for outstanding auto-dispensing and auto-placement in high volume assemblies. SIL PAD 1500ST is intended for placement between an electronic power device and its heat sink.

### TYPICAL PROPERTIES OF SIL PAD 1500ST

PROPERTY	IMPERIAL VALUE	METRIC VALUE	TEST METHOD			
Color	Blue	Blue	Visual			
Reinforcement Carrier	Fiberglass	Fiberglass	—			
Thickness (in.) / (mm)	0.008	0.203	ASTM D374			
Hardness (Shore 00)	75	75	ASTM D2240			
Breaking Strength (lbs./in.) / (kN/m)	1.9	0.34	ASTM D1458			
Elongation (% at 45° to Warp and Fill)	22	22	ASTM D412			
Tensile Strength (psi) / (mPa)	238	1.6	ASTM D412			
Continuous Use Temp. (°F) / (°C)	-76 to 356	-60 to 180	—			
<b>ELECTRICAL</b>						
Dielectric Breakdown Voltage (Vac.)	3,000	3,000	ASTM D149			
Dielectric Constant (1,000 Hz)	6.1	6.1	ASTM D150			
Volume Resistivity (Ohmmeter)	10 <sup>11</sup>	10 <sup>11</sup>	ASTM D257			
Flame Rating	V-O	V-O	UL 94			
<b>THERMAL</b>						
Thermal Conductivity (W/m-K)	1.8	1.8	ASTM D5470			
<b>THERMAL PERFORMANCE VS. PRESSURE</b>						
	Pressure (psi)	10	25	50	100	200
	TO-220 Thermal Performance (°C/W)	1.54	1.52	1.51	1.49	1.46
	Thermal Impedance (°C-in. <sup>2</sup> /W) <sup>1)</sup>	0.37	0.28	0.23	0.21	0.20
1) The ASTM D5470 test fixture was used. The recorded value includes interfacial thermal resistance. These values are provided for reference only. Actual application performance is directly related to the surface roughness, flatness and pressure applied.						

### Typical Applications Include:

- Power supplies
- Power semiconductors
- Aerospace
- Motor controls

### Configurations Available:

- Sheet form, die-cut parts and slit-to-width roll form

### Building a Part Number

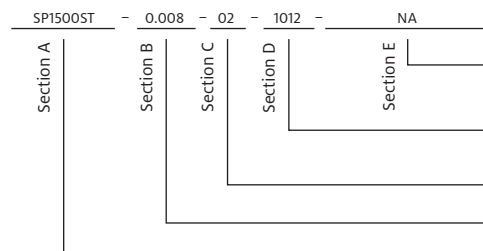

### Standard Options

#### ◀ example

NA = Selected standard option. If not selecting a standard option, insert company name, drawing number, and revision level.

— = Standard configuration dash number, 1012 = 10" x 12" sheets, 10/250 = 10" x 250-foot rolls, or 00 = custom configuration

02 = Natural tack, both sides

Standard thicknesses available: 0.008"

SP1500ST = SIL-PAD 1500ST Material

Note: To build a part number, go to [www.bergquistcompany.com/Part\\_Number\\_Builder.php](http://www.bergquistcompany.com/Part_Number_Builder.php).

# SIL PAD 2000

## Higher Performance, High Reliability Insulator

### Features and Benefits

- Thermal impedance: 0.33°C-in.<sup>2</sup>/W (@ 50 psi)
- Optimal heat transfer
- High thermal conductivity: 3.5 W/m-K



SIL PAD 2000 is a high performance, thermally conductive insulator designed for demanding aerospace and commercial applications.

SIL PAD 2000 is a silicone elastomer formulated to maximize the thermal and dielectric performance of the filler/binder matrix. The result is a grease-free, conformable material capable of meeting or exceeding the thermal and electrical requirements of high-reliability electronic packaging applications.

TYPICAL PROPERTIES OF SIL PAD 2000						
PROPERTY	IMPERIAL VALUE	METRIC VALUE	TEST METHOD			
Color	White	White	Visual			
Reinforcement Carrier	Fiberglass	Fiberglass	—			
Thickness (in.) / (mm)	0.010 to 0.020	0.254 to 0.508	ASTM D374			
Hardness (Shore A)	90	90	ASTM D2240			
Continuous Use Temp. (°F) / (°C)	-76 to 392	-60 to 200	—			
<b>ELECTRICAL</b>						
Dielectric Breakdown Voltage (Vac.)	4,000	4,000	ASTM D149			
Dielectric Constant (1,000 Hz)	4.0	4.0	ASTM D150			
Volume Resistivity (Ohmmeter)	10 <sup>11</sup>	10 <sup>11</sup>	ASTM D257			
Flame Rating	V-0	V-0	UL94			
<b>THERMAL</b>						
Thermal Conductivity (W/m-K)	3.5	3.5	ASTM D5470			
<b>THERMAL PERFORMANCE VS. PRESSURE</b>						
	Pressure (psi)	10	25	50	100	200
	TO-220 Thermal Performance (°C/W) 0.010"	2.61	2.32	2.02	1.65	1.37
	Thermal Impedance (°C-in. <sup>2</sup> /W) 0.010" <sup>(1)</sup>	0.57	0.43	0.33	0.25	0.20

1) The ASTM D5470 test fixture was used. The recorded value includes interfacial thermal resistance. These values are provided for reference only. Actual application performance is directly related to the surface roughness, flatness and pressure applied.

### Typical Applications Include:

- Power supplies
- Motor controls
- Power semiconductors
- Aerospace
- Avionics

### Configurations Available:

- Sheet form, die-cut parts
- With or without pressure sensitive adhesive

### Building a Part Number

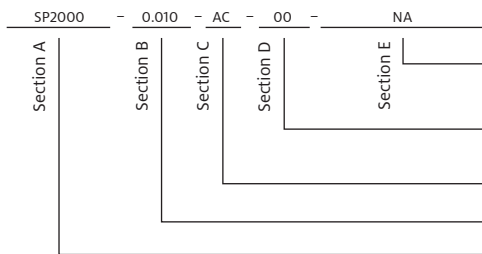

### Standard Options

⚡ **example**

NA = Selected standard option. If not selecting a standard option, insert company name, drawing number, and revision level.

\_\_\_ = Standard configuration dash number, 1212 = 12" x 12" sheets, or 00 = custom configuration

AC = Adhesive, one side  
00 = No adhesive

Standard thicknesses available: 0.010", 0.015", 0.020"

SP2000 = SIL-PAD 2000 Material

Note: To build a part number, go to [www.bergquistcompany.com/Part\\_Number\\_Builder.php](http://www.bergquistcompany.com/Part_Number_Builder.php).

# SIL PAD A2000

## Higher Performance, High Reliability Insulator

### Features and Benefits

- Thermal impedance: 0.32°C-in.<sup>2</sup>/W (@ 50 psi)
- Optimal heat transfer
- High thermal conductivity: 3.0 W/m-K



SIL PAD A2000 is a conformable elastomer with very high thermal conductivity that acts as a thermal interface between electrical components and heat sinks. SIL PAD A2000 is for applications where optimal heat transfer is a requirement.

This thermally conductive silicone elastomer is formulated to maximize the thermal and dielectric performance of the filler/binder matrix. The result is a grease-free, conformable material capable of meeting or exceeding the thermal and electrical requirements of high reliability electronic packaging applications.

### TYPICAL PROPERTIES OF SIL PAD A2000

PROPERTY	IMPERIAL VALUE	METRIC VALUE	TEST METHOD			
Color	White	White	Visual			
Reinforcement Carrier	Fiberglass	Fiberglass	—			
Thickness (in.) / (mm)	0.015 to 0.020	0.381 to 0.508	ASTM D374			
Hardness (Shore A)	90	90	ASTM D2240			
Heat Capacity (J/g-K)	1.0	1.0	ASTM E1269			
Continuous Use Temp. (°F) / (°C)	-76 to 392	-60 to 200	—			
<b>ELECTRICAL</b>						
Dielectric Breakdown Voltage (Vac.)	4,000	4,000	ASTM D149			
Dielectric Constant (1,000 Hz)	7.0	7.0	ASTM D150			
Volume Resistivity (Ohmmeter)	10 <sup>11</sup>	10 <sup>11</sup>	ASTM D257			
Flame Rating	V-O	V-O	UL94			
<b>THERMAL</b>						
Thermal Conductivity (W/m-K)	3.0	3.0	ASTM D5470			
<b>THERMAL PERFORMANCE VS. PRESSURE</b>						
	Pressure (psi)	10	25	50	100	200
TO-220 Thermal Performance (°C/W) 0.015 in.		2.05	1.94	1.86	1.79	1.72
Thermal Impedance (°C-in. <sup>2</sup> /W) 0.015 in. <sup>(1)</sup>		0.53	0.40	0.32	0.28	0.26
1) The ASTM D5470 test fixture was used. The recorded value includes interfacial thermal resistance. These values are provided for reference only. Actual application performance is directly related to the surface roughness, flatness and pressure applied.						

### Typical Applications Include:

- Motor drive controls
- Avionics
- High-voltage power supplies
- Power transistor / heat sink interface

### Configurations Available:

- Sheet form, die-cut parts and roll form
- With or without pressure sensitive adhesive

### Building a Part Number

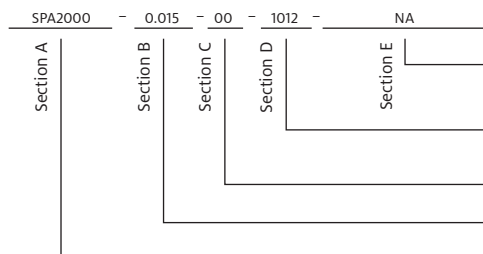

### Standard Options

#### ◀ example

NA = Selected standard option. If not selecting a standard option, insert company name, drawing number, and revision level.

\_\_\_ = Standard configuration dash number,  
1012 = 10" x 12" sheets, 10/250 = 10" x 250-foot rolls, or  
00 = custom configuration

AC = Adhesive, one side  
00 = No adhesive

Standard thicknesses available: 0.015", 0.020"

SPA2000 = SIL-PAD A2000 Material

Note: To build a part number, go to [www.bergquistcompany.com/Part\\_Number\\_Builder.php](http://www.bergquistcompany.com/Part_Number_Builder.php).



# SIL PAD K-4

## The Polyimide-Based Insulator

### Features and Benefits

- Thermal impedance: 0.48°C-in.<sup>2</sup>/W (@ 50 psi)
- Withstands high voltages
- High dielectric strength
- Very durable

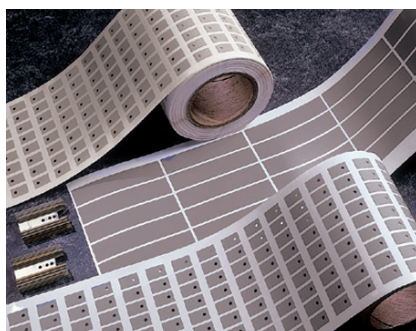

SIL PAD K-4 uses a specially developed film which has high thermal conductivity, high dielectric strength and is very durable. SIL PAD K-4 combines the thermal transfer properties of well-known SIL PAD rubber with the physical properties of a film.

SIL PAD K-4 is a durable insulator that withstands high voltages and requires no thermal grease to transfer heat. SIL PAD K-4 is available in customized shapes and sizes.

### TYPICAL PROPERTIES OF SIL PAD K-4

PROPERTY	IMPERIAL VALUE	METRIC VALUE	TEST METHOD			
Color	Grey	Grey	Visual			
Reinforcement Carrier	Polyimide	Polyimide	—			
Thickness (in.) / (mm)	0.006	0.152	ASTM D374			
Hardness (Shore A)	90	90	ASTM D2240			
Breaking Strength (lbs./in.) / (kN/m)	30	5	ASTM D1458			
Elongation (%)	40	40	ASTM D412			
Tensile Strength (psi) / (mPa)	5,000	34	ASTM D412			
Continuous Use Temp. (°F) / (°C)	-76 to 356	-60 to 180	—			
<b>ELECTRICAL</b>						
Dielectric Breakdown Voltage (Vac.)	6,000	6,000	ASTM D149			
Dielectric Constant (1,000 Hz)	5.0	5.0	ASTM D150			
Volume Resistivity (Ohmmeter)	10 <sup>12</sup>	10 <sup>12</sup>	ASTM D257			
Flame Rating	VTM-O	VTM-O	UL 94			
<b>THERMAL</b>						
Thermal Conductivity (W/m-K)	0.9	0.9	ASTM D5470			
<b>THERMAL PERFORMANCE VS. PRESSURE</b>						
	Pressure (psi)	10	25	50	100	200
	TO-220 Thermal Performance (°C/W)	3.66	3.43	3.13	2.74	2.42
	Thermal Impedance (°C-in. <sup>2</sup> /W) <sup>1)</sup>	1.07	0.68	0.48	0.42	0.38
1) The ASTM D5470 test fixture was used. The recorded value includes interfacial thermal resistance. These values are provided for reference only. Actual application performance is directly related to the surface roughness, flatness and pressure applied.						

### Typical Applications Include:

- Power supplies
- Motor controls
- Power semiconductors

### Configurations Available:

- Sheet form, die-cut parts and roll form
- With or without pressure sensitive adhesive

### Building a Part Number

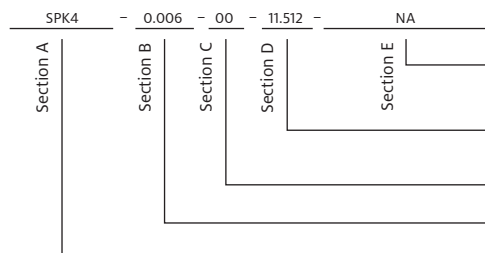

### Standard Options

⚡ **example**

NA = Selected standard option. If not selecting a standard option, insert company name, drawing number, and revision level.

\_\_\_ = Standard configuration dash number, 11.512 = 11.5" x 12" sheets, 11.5/250 = 11.5" x 250-foot rolls, or 00 = custom configuration

AC = Adhesive, one side  
00 = No adhesive

Standard thicknesses available: 0.006"

SPK4 = SIL-PAD K4 Material

Note: To build a part number, go to [www.bergquistcompany.com/Part\\_Number\\_Builder.php](http://www.bergquistcompany.com/Part_Number_Builder.php).

# SIL PAD K-6

## The Medium Performance Polyimide-Based Insulator

### Features and Benefits

- Thermal impedance: 0.49°C-in.<sup>2</sup>/W (@ 50 psi)
- Physically strong dielectric barrier against cut-through
- Medium performance film

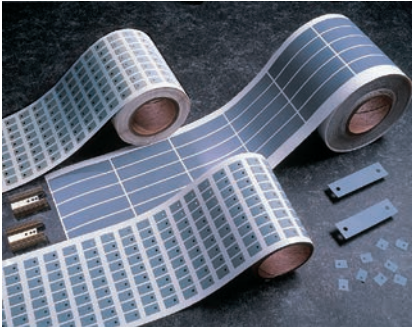

SIL PAD K-6 is a medium performance, film-based thermally conductive insulator. The film is coated with a silicone elastomer to deliver high performance and provide a continuous, physically strong dielectric barrier against “cut-through” and resultant assembly failures.

### TYPICAL PROPERTIES OF SIL PAD K-6

PROPERTY	IMPERIAL VALUE	METRIC VALUE	TEST METHOD			
Color	Blue-green	Blue-green	Visual			
Reinforcement Carrier	Polyimide	Polyimide	—			
Thickness (in.) / (mm)	0.006	0.152	ASTM D374			
Hardness (Shore A)	90	90	ASTM D2240			
Breaking Strength (lbs./in.) / (kN/m)	30	5	ASTM D1458			
Elongation (%)	40	40	ASTM D412			
Tensile Strength (psi) / (mPa)	5,000	34	ASTM D412			
Continuous Use Temp. (°F) / (°C)	-76 to 356	-60 to 180	—			
<b>ELECTRICAL</b>						
Dielectric Breakdown Voltage (Vac.)	6,000	6,000	ASTM D149			
Dielectric Constant (1,000 Hz)	4.0	4.0	ASTM D150			
Volume Resistivity (Ohmmeter)	10 <sup>12</sup>	10 <sup>12</sup>	ASTM D257			
Flame Rating	VTM-O	VTM-O	UL 94			
<b>THERMAL</b>						
Thermal Conductivity (W/m-K)	1.1	1.1	ASTM D5470			
<b>THERMAL PERFORMANCE VS. PRESSURE</b>						
	Pressure (psi)	10	25	50	100	200
	TO-220 Thermal Performance (°C/W)	3.24	3.03	2.76	2.45	2.24
	Thermal Impedance (°C-in. <sup>2</sup> /W) <sup>1)</sup>	0.82	0.62	0.49	0.41	0.36
1) The ASTM D5470 test fixture was used. The recorded value includes interfacial thermal resistance. These values are provided for reference only. Actual application performance is directly related to the surface roughness, flatness and pressure applied.						

### Typical Applications Include:

- Power supplies
- Motor controls
- Power semiconductors

### Configurations Available:

- Sheet form, die-cut parts and roll form
- With or without pressure sensitive adhesive

### Building a Part Number

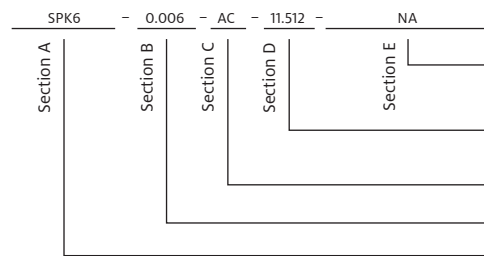

### Standard Options

#### example

NA = Selected standard option. If not selecting a standard option, insert company name, drawing number, and revision level.

\_\_\_ = Standard configuration dash number, 11.512 = 11.5" x 12" sheets, 11.5/250 = 11.5" x 250-foot rolls, or 00 = custom configuration

AC = Adhesive, one side  
00 = No adhesive

Standard thicknesses available: 0.006"

SPK6 = SIL-PAD K6 Material

Note: To build a part number, go to [www.bergquistcompany.com/Part\\_Number\\_Builder.php](http://www.bergquistcompany.com/Part_Number_Builder.php).

# SIL PAD K-10

## The High Performance Polyimide-Based Insulator

### Features and Benefits

- Thermal impedance: 0.41°C-in.<sup>2</sup>/W (@ 50 psi)
- Tough dielectric barrier against cut-through
- High performance film
- Designed to replace ceramic insulators

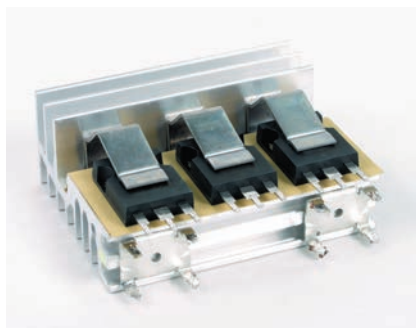

SIL PAD K-10 is a high performance insulator. It combines special film with a filled silicone rubber. The result is a product with good cut-through properties and excellent thermal performance.

SIL PAD K-10 is designed to replace ceramic insulators such as Beryllium Oxide, Boron Nitride and Alumina. Ceramic insulators are expensive and they break easily. SIL PAD K-10 reduces breakage and costs less than ceramics.

TYPICAL PROPERTIES OF SIL PAD K-10						
PROPERTY	IMPERIAL VALUE	METRIC VALUE	TEST METHOD			
Color	Beige	Beige	Visual			
Reinforcement Carrier	Polyimide	Polyimide	—			
Thickness (in.) / (mm)	0.006	0.152	ASTM D374			
Hardness (Shore A)	90	90	ASTM D2240			
Breaking Strength (lbs./in.) / (kN/m)	30	5	ASTM D1458			
Elongation (%)	40	40	ASTM D412			
Tensile Strength (psi) / (mPa)	5,000	34	ASTM D412			
Continuous Use Temp. (°F) / (°C)	-76 to 356	-60 to 180	—			
<b>ELECTRICAL</b>						
Dielectric Breakdown Voltage (Vac.)	6,000	6,000	ASTM D149			
Dielectric Constant (1,000 Hz)	3.7	3.7	ASTM D150			
Volume Resistivity (Ohmmeter)	10 <sup>12</sup>	10 <sup>12</sup>	ASTM D257			
Flame Rating	VTM-O	VTM-O	UL 94			
<b>THERMAL</b>						
Thermal Conductivity (W/m-K)	1.3	1.3	ASTM D5470			
<b>THERMAL PERFORMANCE VS. PRESSURE</b>						
	Pressure (psi)	10	25	50	100	200
	TO-220 Thermal Performance (°C/W)	2.35	2.19	2.01	1.87	1.76
	Thermal Impedance (°C-in. <sup>2</sup> /W) <sup>1)</sup>	0.86	0.56	0.41	0.38	0.33
1) The ASTM D5470 test fixture was used. The recorded value includes interfacial thermal resistance. These values are provided for reference only. Actual application performance is directly related to the surface roughness, flatness and pressure applied.						

### Typical Applications Include:

- Power supplies
- Motor controls
- Power semiconductors

### Configurations Available:

- Sheet form, die-cut parts and roll form
- With or without pressure sensitive adhesive

### Building a Part Number

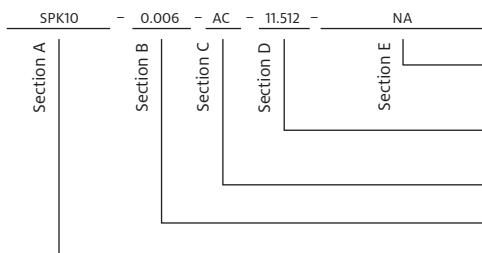

### Standard Options

⚡ **example**

NA = Selected standard option. If not selecting a standard option, insert company name, drawing number, and revision level.

\_\_\_ = Standard configuration dash number, 11.512 = 11.5" x 12" sheets, 11.5/250 = 11.5" x 250-foot rolls, or 00 = custom configuration

AC = Adhesive, one side  
00 = No adhesive

Standard thicknesses available: 0.006"

SPK10 = SIL-PAD K10 Material

Note: To build a part number, go to [www.bergquistcompany.com/Part\\_Number\\_Builder.php](http://www.bergquistcompany.com/Part_Number_Builder.php).

## Q-PAD II

### Foil-Format Grease Replacement for Maximum Heat Transfer

#### Features and Benefits

- Thermal impedance: 0.22°C-in.<sup>2</sup>/W (@ 50 psi)
- Maximum heat transfer
- Aluminum foil-coated both sides
- Designed to replace thermal grease



Q-Pad II is a composite of aluminum foil-coated on both sides with thermally/electrically conductive SIL PAD rubber. The material is designed for those applications in which maximum heat transfer is needed and electrical isolation is not required. Q-PAD II is the ideal thermal interface material to replace messy thermal grease compounds.

Q-PAD II eliminates problems associated with grease such as contamination of reflow solder or cleaning operations. Unlike grease, Q-PAD II can be used prior to these operations. Q-PAD II also eliminates dust collection which can cause possible surface shorting or heat buildup.

#### TYPICAL PROPERTIES OF Q-PAD II

PROPERTY	IMPERIAL VALUE	METRIC VALUE	TEST METHOD			
Color	Black	Black	Visual			
Reinforcement Carrier	Aluminum	Aluminum	—			
Thickness (in.) / (mm)	0.006	0.152	ASTM D374			
Hardness (Shore A)	93	93	ASTM D2240			
Continuous Use Temp. (°F) / (°C)	-76 to 356	-60 to 180	—			
<b>ELECTRICAL</b>						
Dielectric Breakdown Voltage (Vac.)	Non-Insulating	Non-Insulating	ASTM D149			
Dielectric Constant (1,000 Hz)	N/A	N/A	ASTM D150			
Volume Resistivity (Ohmmeter)	10 <sup>2</sup>	10 <sup>2</sup>	ASTM D257			
Flame Rating	V-O	V-O	UL 94			
<b>THERMAL</b>						
Thermal Conductivity (W/m-K)	2.5	2.5	ASTM D5470			
<b>THERMAL PERFORMANCE VS. PRESSURE</b>						
	Pressure (psi)	10	25	50	100	200
	TO-220 Thermal Performance (°C/W)	2.44	1.73	1.23	1.05	0.92
	Thermal Impedance (°C-in. <sup>2</sup> /W) <sup>(1)</sup>	0.52	0.30	0.22	0.15	0.12

1) The ASTM D5470 test fixture was used. The recorded value includes interfacial thermal resistance. These values are provided for reference only. Actual application performance is directly related to the surface roughness, flatness and pressure applied.

#### Typical Applications Include:

- Between a transistor and a heat sink
- Between two large surfaces such as an L-bracket and the chassis of an assembly
- Between a heat sink and a chassis
- Under electrically isolated power modules or devices such as resistors, transformers and solid state relays

#### Configurations Available:

- Sheet form, die-cut parts and roll form
- With or without pressure sensitive adhesive

#### Building a Part Number

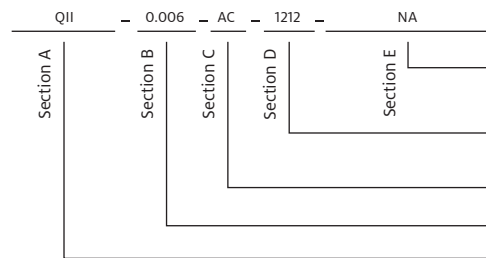

#### Standard Options

##### ◀ example

NA = Selected standard option. If not selecting a standard option, insert company name, drawing number, and revision level.

\_\_\_ = Standard configuration dash number,  
1212 = 12" x 12" sheets, 12/250 = 12" x 250-foot rolls, or  
00 = custom configuration

AC = Adhesive, one side  
00 = No adhesive

Standard thicknesses available: 0.006"

QII = Q-PAD II Material

Note: To build a part number, go to [www.bergquistcompany.com/Part\\_Number\\_Builder.php](http://www.bergquistcompany.com/Part_Number_Builder.php).

## Q-PAD 3

## Glass-Reinforced Grease Replacement Thermal Interface

## Features and Benefits

- Thermal impedance:  $0.35^{\circ}\text{C}\cdot\text{in.}^2/\text{W}$  (@ 50 psi)
- Does away with processing constraints typically associated with grease
- Conforms to surface textures
- Easy handling
- May be installed prior to soldering and cleaning with confidence

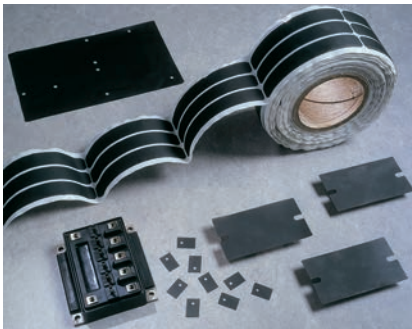

BERGQUIST Q-PAD 3 is a grease-only replacement that does away with contamination of electronic assemblies and reflow solder baths. Q-PAD 3 may be installed prior to soldering and cleaning with confidence. When clamped between two surfaces, the elastomer conforms to surface textures, thereby creating an air-free interface between heat-generating components and heat sinks.

Fiberglass reinforcement enables Q-PAD 3 to withstand processing stresses without losing physical integrity. It also provides ease of handling during application.

## TYPICAL PROPERTIES OF Q-PAD 3

PROPERTY	IMPERIAL VALUE	METRIC VALUE	TEST METHOD			
Color	Black	Black	Visual			
Reinforcement Carrier	Fiberglass	Fiberglass	—			
Thickness (in.) / (mm)	0.005	0.127	ASTM D374			
Hardness (Shore A)	86	86	ASTM D2240			
Continuous Use Temp. (°F) / (°C)	-76 to 356	-60 to 180	—			
<b>ELECTRICAL</b>						
Dielectric Breakdown Voltage (Vac.)	Non-Insulating	Non-Insulating	ASTM D149			
Dielectric Constant (1,000 Hz)	N/A	N/A	ASTM D150			
Volume Resistivity (Ohmmeter)	$10^2$	$10^2$	ASTM D257			
Flame Rating	V-O	V-O	UL 94			
<b>THERMAL</b>						
Thermal Conductivity (W/m-K)	2.0	2.0	ASTM D5470			
<b>THERMAL PERFORMANCE VS. PRESSURE</b>						
	Pressure (psi)	10	25	50	100	200
	TO-220 Thermal Performance ( $^{\circ}\text{C}/\text{W}$ )	2.26	1.99	1.76	1.53	1.30
	Thermal Impedance ( $^{\circ}\text{C}\cdot\text{in.}^2/\text{W}$ ) <sup>(1)</sup>	0.65	0.48	0.35	0.24	0.16

1) The ASTM D5470 test fixture was used. The recorded value includes interfacial thermal resistance. These values are provided for reference only. Actual application performance is directly related to the surface roughness, flatness and pressure applied.

## Typical Applications Include:

- Between a transistor and a heat sink
- Between two large surfaces such as an L-bracket and the chassis of an assembly
- Between a heat sink and a chassis
- Under electrically isolated power modules or devices such as resistors, transformers and solid state relays

## Configurations Available:

- Sheet form, die-cut parts and roll form
- With or without pressure sensitive adhesive

## Building a Part Number

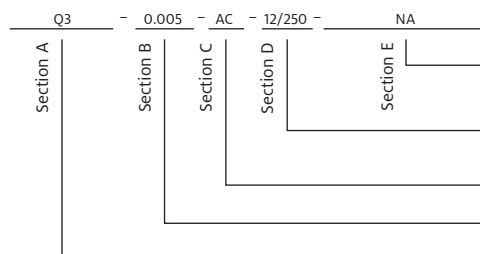

## Standard Options

## ◀ example

NA = Selected standard option. If not selecting a standard option, insert company name, drawing number, and revision level.

\_\_\_ = Standard configuration dash number, 1212 = 12" x 12" sheets, 12/250 = 12" x 250-foot rolls, or 00 = custom configuration

AC = Adhesive, one side  
00 = No adhesive

Standard thicknesses available: 0.005"

Q3 = Q-PAD 3 Material

Note: To build a part number, go to [www.bergquistcompany.com/Part\\_Number\\_Builder.php](http://www.bergquistcompany.com/Part_Number_Builder.php).



# POLY-PAD 400

## Polyester-Based, Thermally Conductive Insulation Material

### Features and Benefits

- Thermal impedance: 1.13°C-in.<sup>2</sup>/W (@ 50 psi)
- Polyester-based
- For applications requiring conformal coatings
- Designed for silicone-sensitive standard applications

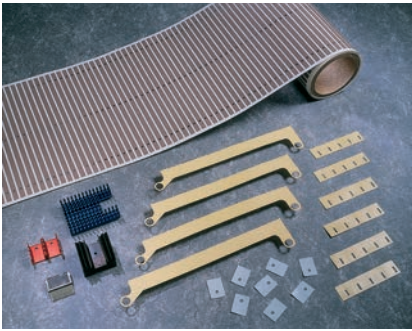

POLY-PAD 400 is a fiberglass-reinforced insulator coated with a filled polyester resin. POLY-PAD 400 is economical and designed for most standard applications.

Polyester-based, thermally conductive BERGQUIST insulators provide a complete family of materials for silicone-sensitive applications. POLY-PADs are ideally suited for applications requiring conformal coatings or applications where silicone contamination is a concern (telecomm and certain aerospace applications). POLY-PADs are constructed with ceramic-filled polyester resins coating either side of a fiberglass carrier or a film carrier. The POLY-PAD family offers a complete range of performance characteristics to match individual applications.

### TYPICAL PROPERTIES OF POLY-PAD 400

PROPERTY	IMPERIAL VALUE	METRIC VALUE	TEST METHOD			
Color	Tan	Tan	Visual			
Reinforcement Carrier	Fiberglass	Fiberglass	—			
Thickness (in.) / (mm)	0.009	0.229	ASTM D374			
Hardness (Shore A)	90	90	ASTM D2240			
Breaking Strength (lbs./in.)/(kN/m)	100	18	ASTM D1458			
Elongation(% at 45° to Warp and Fill)	10	10	ASTM D412			
Tensile Strength (psi) / (mPa)	7,000	48	ASTM D412			
Continuous Use Temp. (°F) / (°C)	-4 to 302	-20 to 150	—			
<b>ELECTRICAL</b>						
Dielectric Breakdown Voltage (Vac.)	2,500	2,500	ASTM D149			
Dielectric Constant (1,000 Hz)	5.5	5.5	ASTM D150			
Volume Resistivity (Ohmmeter)	10 <sup>11</sup>	10 <sup>11</sup>	ASTM D257			
<b>THERMAL</b>						
Thermal Conductivity (W/m-K)	0.9	0.9	ASTM D5470			
Flame Rating	V-O	V-O	UL 94			
<b>THERMAL PERFORMANCE VS. PRESSURE</b>						
	Pressure (psi)	10	25	50	100	200
	TO-220 Thermal Performance (°C/W)	5.85	5.61	5.13	4.59	4.12
	Thermal Impedance (°C-in. <sup>2</sup> /W) <sup>(1)</sup>	1.62	1.35	1.13	0.86	0.61
1) The ASTM D5470 test fixture was used. The recorded value includes interfacial thermal resistance. These values are provided for reference only. Actual application performance is directly related to the surface roughness, flatness and pressure applied.						

### Typical Applications Include:

- Power supplies
- Automotive electronics
- Motor controls
- Power semiconductors

### Configurations Available:

- Sheet form, die-cut parts and roll form
- With or without pressure sensitive adhesive
- We produce thousands of specials. Tooling charges vary depending on tolerances and the complexity of the part.

### Building a Part Number

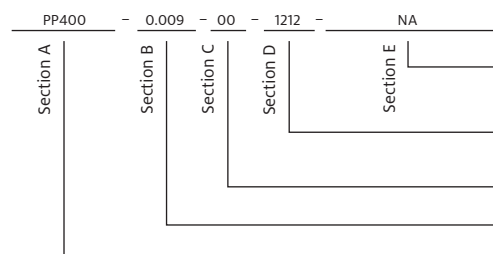

### Standard Options

#### ◀ example

NA = Selected standard option. If not selecting a standard option, insert company name, drawing number, and revision level.

\_\_\_ = Standard configuration dash number,  
 1212 = 12" x 12" sheets, 12/250 = 12" x 250-foot rolls, or  
 00 = custom configuration

AC = Adhesive, one side  
 00 = No adhesive

Standard thicknesses available: 0.009"

PP400 = POLY-PAD 400 Material

Note: To build a part number, go to [www.bergquistcompany.com/Part\\_Number\\_Builder.php](http://www.bergquistcompany.com/Part_Number_Builder.php).

## POLY-PAD 1000

## Polyester-Based, Thermally Conductive Insulation Material

## Features and Benefits

- Thermal impedance: 0.82°C-in.<sup>2</sup>/W (@ 50 psi)
- Polyester-based
- For applications requiring non-silicone conformal coatings
- Designed for silicone-sensitive applications requiring high performance



POLY-PAD 1000 is a fiberglass-reinforced insulator coated with a filled polyester resin. The material offers exceptional thermal resistance for high performance applications.

BERGQUIST polyester-based, thermally conductive insulators provide a complete family of materials for silicone-sensitive applications. POLY-PADs are ideally suited for applications requiring conformal coatings or applications where silicone contamination is a concern (telecom and certain aerospace applications). POLY-PADs are constructed with ceramic-filled polyester resins coating either side of a fiberglass carrier or a film carrier. The POLY-PAD family offers a complete range of performance characteristics to match individual applications.

## TYPICAL PROPERTIES OF POLY-PAD 1000

PROPERTY	IMPERIAL VALUE	METRIC VALUE	TEST METHOD			
Color	Yellow	Yellow	Visual			
Reinforcement Carrier	Fiberglass	Fiberglass	—			
Thickness (in.) / (mm)	0.009	0.229	ASTM D374			
Hardness (Shore A)	90	90	ASTM D2240			
Breaking Strength (lbs./in.) / (kN/m)	100	18	ASTM D1458			
Elongation (%)	10	10	ASTM D412			
Tensile Strength (psi) / (mPa)	7,000	48	ASTM D412			
Continuous Use Temp. (°F) / (°C)	-4 to 302	-20 to 150	—			
<b>ELECTRICAL</b>						
Dielectric Breakdown Voltage (Vac.)	2,500	2,500	ASTM D149			
Dielectric Constant (1,000 Hz)	4.5	4.5	ASTM D150			
Volume Resistivity (Ohmmeter)	10 <sup>11</sup>	10 <sup>11</sup>	ASTM D257			
<b>THERMAL</b>						
Thermal Conductivity (W/m-K)	1.2	1.2	ASTM D5470			
<b>THERMAL PERFORMANCE VS. PRESSURE</b>						
	Pressure (psi)	10	25	50	100	200
	TO-220 Thermal Performance (°C/W)	4.70	4.25	3.74	3.27	2.89
	Thermal Impedance (°C-in. <sup>2</sup> /W) <sup>(1)</sup>	1.30	1.02	0.82	0.61	0.43

1) The ASTM D5470 test fixture was used. The recorded value includes interfacial thermal resistance. These values are provided for reference only. Actual application performance is directly related to the surface roughness, flatness and pressure applied.

## Typical Applications Include:

- Power supplies
- Automotive electronics
- Motor controls
- Power semiconductors

## Configurations Available:

- Sheet form, die-cut parts and roll form
- With or without pressure sensitive adhesive

## Building a Part Number

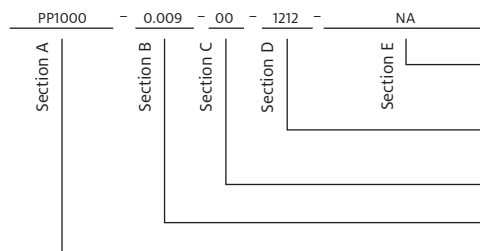

## Standard Options

## ◀ example

NA = Selected standard option. If not selecting a standard option, insert company name, drawing number, and revision level.

\_\_\_ = Standard configuration dash number, 1212 = 12" x 12" sheets, 12/250 = 12" x 250-foot rolls, or 00 = custom configuration

AC = Adhesive, one side  
00 = No adhesive

Standard thicknesses available: 0.009"

PP1000 = POLY-PAD 1000 Material

Note: To build a part number, go to [www.bergquistcompany.com/Part\\_Number\\_Builder.php](http://www.bergquistcompany.com/Part_Number_Builder.php).

# POLY-PAD K-4

## Polyester-Based, Thermally Conductive Insulation Material

### Features and Benefits

- Thermal impedance: 0.95°C-in.<sup>2</sup>/W (@ 50 psi)
- Polyester-based
- For applications requiring non-silicone conformal coatings
- Designed for silicone-sensitive applications
- Excellent dielectric and physical strength

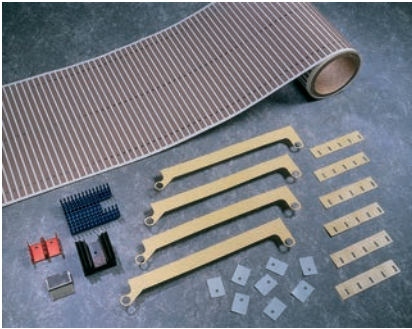

POLY-PAD K-4 is a composite of film coated with a polyester resin. The material is an economical insulator and the film carrier provides excellent dielectric and physical strength.

BERGQUIST polyester-based, thermally conductive insulators provide a complete family of materials for silicone-sensitive applications. POLY-PADs are ideally suited for applications requiring conformal coatings or applications where silicone contamination is a concern (telecom and certain aerospace applications). POLY-PADs are constructed with ceramic-filled polyester resins coating either side of a fiberglass carrier or a film carrier. The POLY-PAD family offers a complete range of performance characteristics to match individual applications.

### TYPICAL PROPERTIES OF POLY-PAD K-4

PROPERTY	IMPERIAL VALUE	METRIC VALUE	TEST METHOD			
Color	Tan	Tan	Visual			
Reinforcement Carrier	Polyimide	Polyimide	—			
Thickness (in.) / (mm)	0.006	0.152	ASTM D374			
Hardness (Shore A)	90	90	ASTM D2240			
Breaking Strength (lbs./in.) / (kN/m)	30	5	ASTM D1458			
Elongation (%)	40	40	ASTM D412			
Tensile Strength (psi) / (mPa)	5,000	34	ASTM D412			
Continuous Use Temp. (°F) / (°C)	-4 to 302	-20 to 150	—			
<b>ELECTRICAL</b>						
Dielectric Breakdown Voltage (Vac.)	6,000	6,000	ASTM D149			
Dielectric Constant (1,000 Hz)	5.0	5.0	ASTM D150			
Volume Resistivity (Ohmmeter)	10 <sup>12</sup>	10 <sup>12</sup>	ASTM D257			
Flame Rating	V-0	V-0	UL 94			
<b>THERMAL</b>						
Thermal Conductivity (W/m-K)	0.9	0.9	ASTM D5470			
<b>THERMAL PERFORMANCE VS. PRESSURE</b>						
	Pressure (psi)	10	25	50	100	200
	TO-220 Thermal Performance (°C/W)	5.64	5.04	4.34	3.69	3.12
	Thermal Impedance (°C-in. <sup>2</sup> /W) <sup>(1)</sup>	1.55	1.21	0.95	0.70	0.46
1) The ASTM D5470 test fixture was used. The recorded value includes interfacial thermal resistance. These values are provided for reference only. Actual application performance is directly related to the surface roughness, flatness and pressure applied.						

### Typical Applications Include:

- Power supplies
- Motor controls
- Power semiconductors

### Configurations Available:

- Sheet form, die-cut parts and roll form
- With or without pressure sensitive adhesive

### Building a Part Number

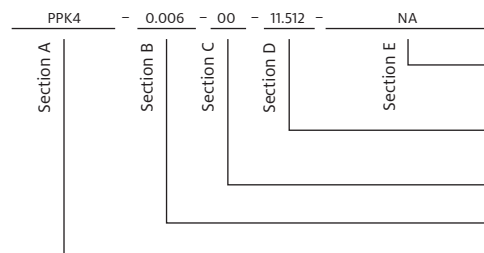

### Standard Options

#### example

NA = Selected standard option. If not selecting a standard option, insert company name, drawing number, and revision level.

\_\_\_ = Standard configuration dash number, 11.512 = 11.5" x 12" sheets, 11.5/250 = 11.5" x 250-foot rolls, or 00 = custom configuration

AC = Adhesive, one side  
00 = No adhesive

Standard thicknesses available: 0.006"

PPK4 = POLY-PAD K-4 Material

Note: To build a part number, go to [www.bergquistcompany.com/Part\\_Number\\_Builder.php](http://www.bergquistcompany.com/Part_Number_Builder.php).

## POLY-PAD K-10

## Polyester-Based, Thermally Conductive Insulation Material

## Features and Benefits

- Thermal impedance: 0.60°C-in.<sup>2</sup>/W (@ 50 psi)
- Polyester-based
- For applications requiring non-silicone conformal coatings
- Designed for silicone-sensitive applications
- Excellent dielectric strength and thermal performance



POLY-PAD K-10 is a composite of film coated with a polyester resin. The material offers exceptional thermal performance for your most critical applications with a thermal resistance of 0.2°C-in.<sup>2</sup>/W as well as excellent dielectric strength.

BERGQUIST polyester-based, thermally conductive insulators provide a complete family of materials for silicone-sensitive applications. POLY-PADs are ideally suited for applications requiring conformal coatings or applications where silicone contamination is a concern (telecom and certain aerospace applications). POLY-PADs are constructed with ceramic-filled polyester resins coating either side of a fiberglass carrier or a film carrier. The POLY-PAD family offers a complete range of performance characteristics to match individual applications.

## TYPICAL PROPERTIES OF POLY-PAD K-10

PROPERTY	IMPERIAL VALUE	METRIC VALUE	TEST METHOD			
Color	Yellow	Yellow	Visual			
Reinforcement Carrier	Polyimide	Polyimide	—			
Thickness (in.) / (mm)	0.006	0.152	ASTM D374			
Hardness (Shore A)	90	90	ASTM D2240			
Breaking Strength (lbs./in.) / (kN/m)	30	5	ASTM D1458			
Elongation (%)	40	40	ASTM D412			
Tensile Strength (psi) / (mPa)	5,000	34	ASTM D412			
Continuous Use Temp. (°F) / (°C)	-4 to 302	-20 to 150	—			
<b>ELECTRICAL</b>						
Dielectric Breakdown Voltage (Vac.)	6,000	6,000	ASTM D149			
Dielectric Constant (1,000 Hz)	3.7	3.7	ASTM D150			
Volume Resistivity (Ohmmeter)	10 <sup>12</sup>	10 <sup>12</sup>	ASTM D257			
Flame Rating	V-O	V-O	UL 94			
<b>THERMAL</b>						
Thermal Conductivity (W/m-K)	1.3	1.3	ASTM D5470			
<b>THERMAL PERFORMANCE VS. PRESSURE</b>						
	Pressure (psi)	10	25	50	100	200
	TO-220 Thermal Performance (°C/W)	3.76	3.35	2.75	2.30	2.03
	Thermal Impedance (°C-in. <sup>2</sup> /W) <sup>1)</sup>	1.04	0.80	0.60	0.43	0.30
1) The ASTM D5470 test fixture was used. The recorded value includes interfacial thermal resistance. These values are provided for reference only. Actual application performance is directly related to the surface roughness, flatness and pressure applied.						

## Typical Applications Include:

- Power supplies
- Motor controls
- Power semiconductors

## Configurations Available:

- Sheet form, die-cut parts and roll form
- With or without pressure sensitive adhesive

## Building a Part Number

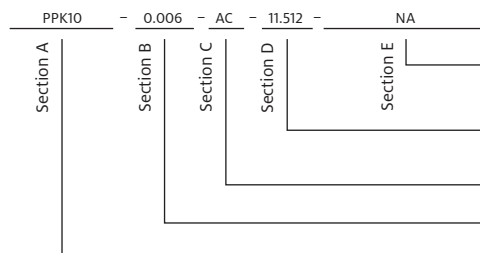

## Standard Options

## ◀ example

NA = Selected standard option. If not selecting a standard option, insert company name, drawing number, and revision level.

\_\_\_ = Standard configuration dash number, 11.512 = 11.5" x 12" sheets, 11.5/250 = 11.5" x 250-foot rolls, or 00 = custom configuration

AC = Adhesive, one side  
00 = No adhesive

Standard thicknesses available: 0.006"

PPK10 = POLY-PAD K-10 Material

Note: To build a part number, go to [www.bergquistcompany.com/Part\\_Number\\_Builder.php](http://www.bergquistcompany.com/Part_Number_Builder.php).

## SIL PAD Tubes

### Silicone-Based, Thermally Conductive Tubes

#### Features and Benefits

- Thermal conductivity: SPT 400 – 0.9 W/m-K SPT 1000 – 1.2 W/m-K
- For clip-mounted plastic power packages



SPT 400 and SPT 1000 (SIL PAD Tubes) provide thermally conductive insulation for clip-mounted plastic power packages. SIL PAD Tubes are made of silicone rubber with high thermal conductivity.

SIL PAD Tube 1000 is best suited for higher thermal performance.

SIL PAD Tube 400 is ideal for applications requiring average thermal conductivity and economy.

SIL PAD Tube 400 and SIL PAD Tube 1000 are designed to meet VDE, UL and TUV agency requirements.

#### Typical Applications

##### Include:

- Clip-mounted power semiconductors
- TO-220, TO-218, TO-247 and TO-3P

##### Configurations Available:

- TO-220, TO-218, TO-247 and TO-3P

#### TYPICAL PROPERTIES OF SIL PAD TUBE 400

PROPERTY	IMPERIAL VALUE	METRIC VALUE	TEST METHOD
Color	Grey/Green	Grey/Green	Visual
Thickness / Wall (in.) / (mm)	0.012	0.305	ASTM D374
Hardness (Shore A)	80	80	ASTM D2240
Breaking Strength (lbs./in.) / (kN/m)	6	1	ASTM D1458
Continuous Use Temp. (°F) / (°C)	-76 to 356	-60 to 180	—
<b>ELECTRICAL</b>			
Dielectric Breakdown Voltage (Vac.)	5,000	5,000	ASTM D149
Dielectric Constant (1,000 Hz)	5.5	5.5	ASTM D150
Volume Resistivity (Ohmmeter)	10 <sup>11</sup>	10 <sup>11</sup>	ASTM D257
Flame Rating	V-0	V-0	UL 94
<b>THERMAL</b>			
Thermal Conductivity (W/m-K)	0.9	0.9	ASTM D5470
Thermal Impedance (°C-in. <sup>2</sup> /W) <sup>1)</sup>	0.6	0.6	ASTM D5470

#### TYPICAL PROPERTIES OF SIL PAD TUBE 1000

PROPERTY	IMPERIAL VALUE	METRIC VALUE	TEST METHOD
Color	Brown	Brown	Visual
Thickness / Wall (in.) / (mm)	0.012	0.30	ASTM D374
Hardness (Shore A)	80	80	ASTM D2240
Breaking Strength (lbs./in.) / (kN/m)	6	1	ASTM D1458
Continuous Use Temp. (°F) / (°C)	-76 to 356	-60 to 180	—
<b>ELECTRICAL</b>			
Dielectric Breakdown Voltage (Vac.)	5,000	5,000	ASTM D149
Dielectric Constant (1,000 Hz)	4.5	4.5	ASTM D150
Volume Resistivity (Ohmmeter)	10 <sup>11</sup>	10 <sup>11</sup>	ASTM D257
Flame Rating	V-0	V-0	UL 94
<b>THERMAL</b>			
Thermal Conductivity (W/m-K)	1.2	1.2	ASTM D5470
Thermal Impedance (°C-in. <sup>2</sup> /W) <sup>1)</sup>	0.4	0.4	ASTM D5470

<sup>1)</sup> The ASTM D5470 test fixture was used. The recorded value includes interfacial thermal resistance. These values are provided for reference only. Actual application performance is directly related to the surface roughness, flatness and pressure applied.

#### Standard Dimensions

A = Wall Thickness: .305 mm (.012 in.) + .10 mm / -0.0 mm (+.004 in. / -0.0 in.)

B = Inner Diameter: 11 mm (.433 in.) or 13.5 mm (.532 in.) ± 1.0 mm (± .039 in.)

C = Length: 25 mm (.985 in.) or 30 mm (1.18 in.) +3.18 mm / -0.0 mm (+ .125 in. / - 0.0 in.)

Special lengths are available. For more information, contact a Henkel Sales Representative.

#### Ordering Procedure:

Sample: SPT 400 \_\_\_ - \_\_\_ - \_\_\_  
"A" - "B" - "C"

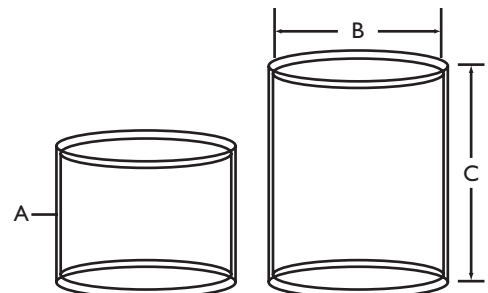



## BOND-PLY and LIQUI-BOND Adhesives

### BOND-PLY Adhesive Tapes

Available in a pressure sensitive adhesive or laminating format, the BOND-PLY family of materials is thermally conductive and electrically isolating. BOND-PLY facilitates the decoupling of bonded materials with mismatched thermal coefficients of expansion.

#### Typical BOND-PLY Applications

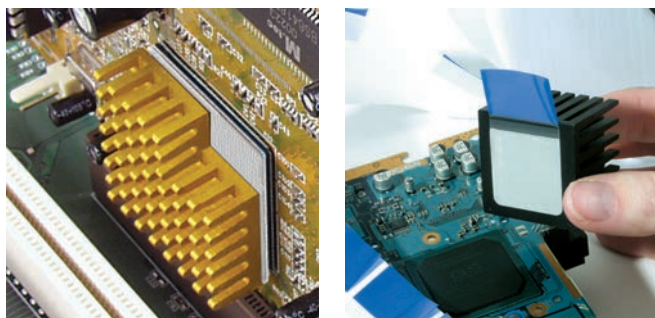

#### Features

- High performance, thermally conductive, pressure sensitive adhesive
- Material immediately bonds to the target surface
- Bond strength increases over time when repeatedly exposed to high continuous-use temperatures

#### Benefits

- Provides an excellent dielectric barrier
- Excellent wet-out to most types of component surfaces including plastic
- BOND-PLY 400 is unreinforced to increase conformance and wet-out on low surface energy materials
- Eliminates need for screws, clip mounts or fasteners

#### Options

- Supplied in sheet, die-cut, roll and tabulated forms
- Available in thickness range of 3 to 11 mil
- Custom coated thickness

#### Applications

- Attach a heat sink to a graphics processing unit
- Attach a heat spreader to a motor control PCB
- Attach a heat sink to a power converter PCB
- Attach a heat sink to a drive processor

### LIQUI-BOND Liquid Adhesives

BERGQUIST LIQUI-BOND liquid adhesives are high performance, thermally conductive, liquid adhesive materials. These form-in-place elastomers are ideal for coupling “hot” electronic components mounted on PC boards with an adjacent metal case or heat sink.

#### Typical LIQUI-BOND Applications

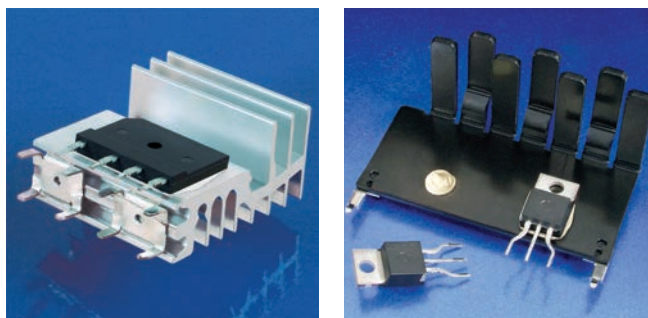

#### Features

- Excellent low and high temperature mechanical and chemical stability

#### Benefits

Before cure, LIQUI-BOND flows under pressure like a grease. After cure, it bonds the components, eliminating the need for mechanical fasteners. Additional benefits include:

- Low modulus provides stress-absorbing flexibility
- Supplied as a one-part material with an elevated temperature curing system
- Offers infinite thickness with little or no stress during displacement
- Eliminates need for specific pad thickness and die-cut shapes for individual applications

#### Options

The growing LIQUI-BOND family offers a variety of choices to meet the customer's performance, handling and process needs.

#### Applications

LIQUI-BOND products are intended for use in thermal interface applications where a structural bond is a requirement. This material is formulated for high cohesive and adhesive strength and cures to a low modulus. Typical applications include:

- Automotive electronics
- Telecommunications
- Computer and peripherals
- Between any heat-generating semiconductor and a heat sink

## Frequently Asked Questions

**Q: What is the primary difference between the BOND-PLY 660B and BOND-PLY 100 products?**

**A:** BOND-PLY 660B uses a dielectric film, replacing the fiberglass inherent in our BOND-PLY 100 series products. The addition of the film allows for high dielectric performance without additional product thickness.

**Q: How should I size my interface dimensions for BOND-PLY?**

**A:** BOND-PLY product testing has been completed on various interface materials. These tests have demonstrated that improper surface wet-out is the single largest variable associated with maximizing bond strength and heat transfer. We have found that reducing the size of the interface pad to roughly 80% of the total interface area actually improves the overall bonding performance while offering significant improvements in total package cooling. Henkel offers three standard thicknesses for BOND-PLY 100, allowing each application to be optimized in three dimensions.

**Q: What application pressure is required to optimize bond strength with BOND-PLY?**

**A:** The answer to this varies from application to application, depending upon surface roughness and flatness. In general, pressure, temperature and time are the primary

variables associated with increasing surface contact or wet-out. Increasing the application time and/or pressure will significantly increase surface contact. Natural wet-out will continue to occur with BOND-PLY materials. This inherent action often increases bond strength by more than two times within the first 24 hours.

**Q: Will BOND-PLY adhere to plastic packages?**

**A:** Adhesive performance on plastic packages is primarily a function of surface contact or wet-out. If surface contaminants such as plastic mold release oils are present, this will prevent contact and/or bonding to the surface. Make sure all surfaces are clean and dry prior to applying BOND-PLY materials.

**Q: How are one-part LIQUI-BOND adhesives cured?**

**A:** One-part LIQUI-BOND requires heat to cure and bond in the application. Altering the bond line temperature and time can control the cure schedule. Component fixturing may be required to maintain placement through cure.

## BOND-PLY Comparison Data

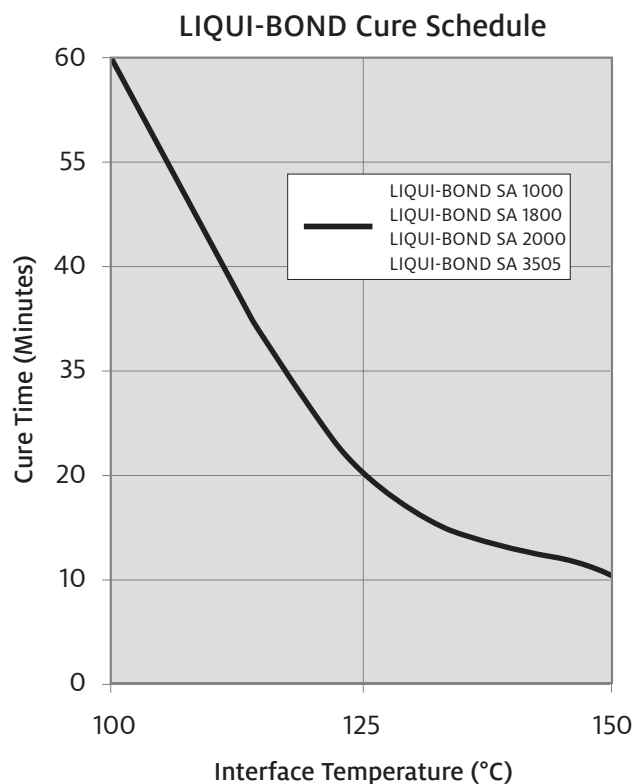
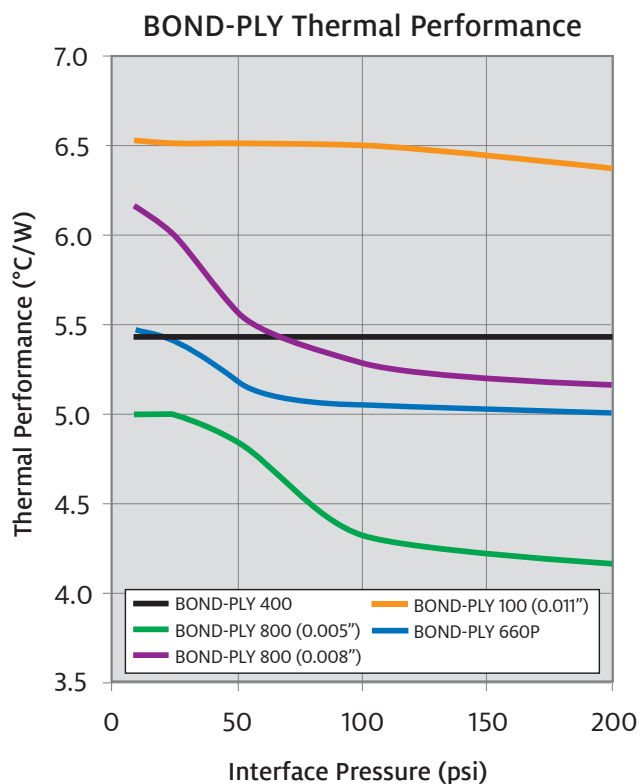

# BOND-PLY 100

## Thermally Conductive, Fiberglass-Reinforced Pressure Sensitive Adhesive Tape

### Features and Benefits

- Thermal impedance: 0.52°C-in.<sup>2</sup>/W (@ 50 psi)
- High bond strength to a variety of surfaces
- Double-sided, pressure sensitive adhesive tape
- High performance, thermally conductive acrylic adhesive
- Can be used instead of heat-cure adhesive, screw mounting or clip mounting

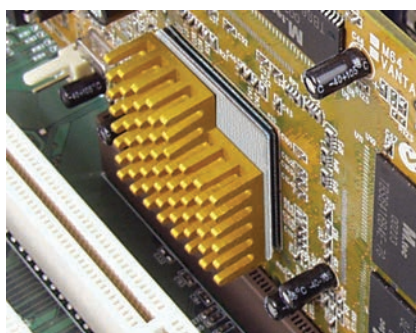

### Typical Applications Include:

- Mount heat sink onto BGA graphic processor or drive processor
- Mount heat spreader onto power converter PCB or onto motor control PCB

### Configurations Available:

- Sheet form, roll form and die-cut parts

**Shelf Life:** The double-sided, pressure sensitive adhesive used in BOND-PLY products requires the use of dual liners to protect the surfaces from contaminants. Henkel recommends a 6-month shelf life at a maximum continuous storage temperature of 35°C or 3-month shelf life at a maximum continuous storage temperature of 45°C, for maintenance of controlled adhesion to the liner. The shelf life of the BOND-PLY material, without consideration of liner adhesion (which is often not critical for manual assembly processing), is recommended at 12 months from date of manufacture at a maximum continuous storage temperature of 60°C.

### TYPICAL PROPERTIES OF BOND-PLY 100

PROPERTY	IMPERIAL VALUE	METRIC VALUE	TEST METHOD		
Color	White	White	Visual		
Reinforcement Carrier	Fiberglass	Fiberglass	—		
Thickness (in.) / (mm)	0.005, 0.008, 0.011	0.127, 0.203, 0.279	ASTM D374		
Temp. Resistance, 30 sec. (°F) / (°C)	392	200	—		
Elongation (% 45° to Warp & Fill)	70	70	ASTM D412		
Tensile Strength (psi) / (mPa)	900	6	ASTM D412		
CTE (ppm)	325	325	ASTM D3386		
Glass Transition (°F) / (°C)	-22	-30	ASTM D1356		
Continuous Use Temp. (°F) / (°C)	-22 to 248	-30 to 120	—		
<b>ADHESION</b>					
Lap Shear @ RT (psi) / (mPa)	100	0.7	ASTM D1002		
Lap Shear after 5 hrs. @ 100°C	200	1.4	ASTM D1002		
Lap Shear after 2 mins. @ 200°C	200	1.4	ASTM D1002		
Static Dead Weight Shear (°F) / (°C)	302	150	PSTC#7		
<b>ELECTRICAL</b>		<b>VALUE</b>	<b>TEST METHOD</b>		
Dielectric Breakdown Voltage - 0.005 in. (Vac.)		3,000	ASTM D149		
Dielectric Breakdown Voltage - 0.008 in. (Vac.)		6,000	ASTM D149		
Dielectric Breakdown Voltage - 0.011 in. (Vac.)		8,500	ASTM D149		
Flame Rating		V-O	UL 94		
<b>THERMAL</b>					
Thermal Conductivity (W/m-K)		0.8	ASTM D5470		
<b>THERMAL PERFORMANCE VS. PRESSURE</b>					
Initial Assembly Pressure (psi for 5 seconds)	10	25	50	100	200
TO-220 Thermal Performance (°C/W) 0.005 in.	5.17	4.87	4.49	4.18	4.10
TO-220 Thermal Performance (°C/W) 0.008 in.	5.40	5.35	5.28	5.22	5.20
TO-220 Thermal Performance (°C/W) 0.011 in.	6.59	6.51	6.51	6.50	6.40
Thermal Impedance (°C-in. <sup>2</sup> /W) 0.005 in. <sup>(1)</sup>	0.56	0.54	0.52	0.50	0.50
Thermal Impedance (°C-in. <sup>2</sup> /W) 0.008 in. <sup>(1)</sup>	0.82	0.80	0.78	0.77	0.75
Thermal Impedance (°C-in. <sup>2</sup> /W) 0.011 in. <sup>(1)</sup>	1.03	1.02	1.01	1.00	0.99
1) The ASTM D5470 test fixture was used. The recorded value includes interfacial thermal resistance. These values are provided for reference only. Actual application performance is directly related to the surface roughness, flatness and pressure applied.					

### Building a Part Number

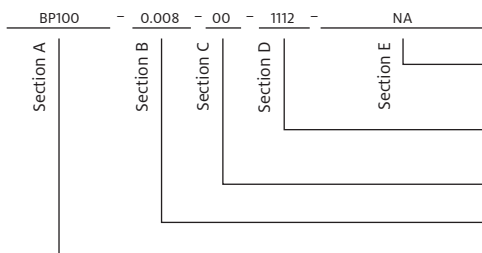

### Standard Options

◀ **example**  
 NA = Selected standard option. If not selecting a standard option, insert company name, drawing number, and revision level.  
 1112 = 11" x 12" sheets, 11250 = 11" x 250-foot rolls or 00 = custom configuration  
 00 = No adhesive  
 Standard thicknesses available: 0.005", 0.008", 0.011"  
 BP100 = BOND-PLY 100 Material

Note: To build a part number, go to [www.bergquistcompany.com/Part\\_Number\\_Builder.php](http://www.bergquistcompany.com/Part_Number_Builder.php).

# BOND-PLY 400

## Thermally Conductive, Unreinforced, Pressure Sensitive Adhesive Tape

### Features and Benefits

- Thermal impedance: 0.87°C-in.<sup>2</sup>/W (@ 50 psi)
- Easy application
- Eliminates need for external hardware (screws, clips, etc.)
- Available with easy release tabs

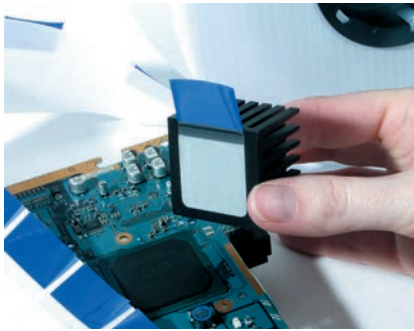

BERGQUIST BOND-PLY 400 is an unreinforced, thermally conductive, pressure sensitive adhesive tape. The tape is supplied with protective topside tabs and a carrier liner. BOND-PLY 400 is designed to attain high bond strength to a variety of “low energy” surfaces, including many plastics, while maintaining high bond strength with long-term exposure to heat and high humidity.

### Typical Applications Include:

#### Secure:

- Heat sink onto BGA graphic processor
- Heat sink to computer processor
- Heat sink onto drive processor
- Heat spreader onto power converter PCB
- Heat spreader onto motor control PCB

### Configurations Available:

- Die-cut parts (supplied on rolls with easy release, protective tabs)

### TYPICAL PROPERTIES OF BOND-PLY 400

PROPERTY	IMPERIAL VALUE	METRIC VALUE	TEST METHOD		
Color	White	White	Visual		
Thickness (in.) / (mm)	0.005 to 0.010	0.127 to 0.254	ASTM D374		
Glass Transition (°F) / (°C)	-22	-30	ASTM E1356		
Continuous Use Temp. (°F) / (°C)	-22 to 248	-30 to 120	—		
<b>ADHESION</b>					
Lap Shear @ RT (psi) / (mPa)	100	0.7	ASTM D1002		
Lap Shear after 5 hrs. @ 100°C	200	1.4	ASTM D1002		
Lap Shear after 2 mins. @ 200°C	200	1.4	ASTM D1002		
<b>ELECTRICAL</b>		<b>VALUE</b>	<b>TEST METHOD</b>		
Dielectric Breakdown Voltage (Vac.)		3,000	ASTM D149		
Flame Rating		V-0	UL 94		
<b>THERMAL</b>					
Thermal Conductivity (W/m-K)		0.4	ASTM D5470		
<b>THERMAL PERFORMANCE VS. PRESSURE</b>					
Initial Assembly Pressure (psi for 5 seconds)	10	25	50	100	200
TO-220 Thermal Performance (°C/W) 0.005 in.	5.4	5.4	5.4	5.4	5.4
Thermal Impedance (°C-in. <sup>2</sup> /W) <sup>(1)</sup>	0.87				
1) The ASTM D5470 test fixture was used. The recorded value includes interfacial thermal resistance. These values are provided for reference only. Actual application performance is directly related to the surface roughness, flatness and pressure applied.					

**Shelf Life:** The double-sided pressure sensitive adhesive used in BOND-PLY products requires the use of dual liners to protect the surfaces from contaminants. Henkel recommends a 6-month shelf life at a maximum continuous storage temperature of 35°C, or 3-month shelf life at a maximum continuous storage temperature of 45°C, for maintenance of controlled adhesion to the liner. The shelf life of the BOND-PLY material, without consideration of liner adhesion (which is often not critical for manual assembly processing), is recommended at 12 months from date of manufacture at a maximum continuous storage temperature of 60°C.

### Building a Part Number

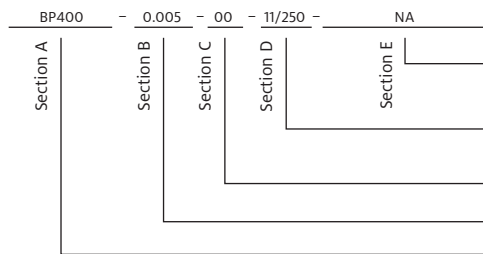

### Standard Options

#### ◀ example

NA = Selected standard option. If not selecting a standard option, insert company name, drawing number, and revision level.

11/250 = 11" x 250-foot rolls or 00 = custom configuration

00 = No adhesive

Standard thicknesses available: 0.005", 0.010"

BP400 = BOND-PLY 400 Material

Note: To build a part number, go to [www.bergquistcompany.com/Part\\_Number\\_Builder.php](http://www.bergquistcompany.com/Part_Number_Builder.php).

## BOND-PLY 660P

## Thermally Conductive, Film Reinforced, Pressure Sensitive Adhesive Tape

## Features and Benefits

- Thermal impedance: 0.87°C-in.<sup>2</sup>/W (@ 50 psi)
- Highly puncture-resistant polyimide reinforcement carrier
- Double-sided pressure sensitive adhesive tape
- Provides a mechanical bond, eliminating the need for mechanical fasteners or screws

BOND-PLY 660P is a thermally conductive, electrically insulating, double-sided pressure sensitive adhesive tape. The tape consists of a high performance, thermally conductive acrylic adhesive coated on both sides of a polyimide film. Use BOND-PLY 660P in applications to replace mechanical fasteners or screws.

## Typical Applications Include:

- Heat sink onto BGA graphic processor
- Heat sink onto drive processor
- Heat spreader onto power converter PCB
- Heat spreader onto motor control PCB

## Configurations Available:

- Roll form and die-cut parts

The material as delivered will include a continuous base liner with differential release properties to allow for simplicity in roll packaging and application assembly.

## TYPICAL PROPERTIES OF BOND-PLY 660P

PROPERTY	IMPERIAL VALUE	METRIC VALUE	TEST METHOD			
Color	Light Brown	Light Brown	Visual			
Reinforcement Carrier	Polyimide Film	Polyimide Film	—			
Thickness (in.) / (mm)	0.008	0.203	ASTM D374			
Glass Transition (°F) / (°C)	-22	-30	ASTM E1356			
Continuous Use Temp. (°F) / (°C)	-22 to 248	-30 to 120	—			
<b>ADHESION</b>						
Lap Shear @ RT (psi) / (mPa)	100	0.7	ASTM D1002			
Lap Shear after 5 hrs. @ 100°C	200	1.4	ASTM D1002			
Lap Shear after 2 mins. @ 200°C	200	1.4	ASTM D1002			
<b>ELECTRICAL</b>		<b>VALUE</b>	<b>TEST METHOD</b>			
Dielectric Breakdown Voltage (VAC)		6,000	ASTM D149			
Flame Rating		V-O	UL 94			
<b>THERMAL</b>						
Thermal Conductivity (W/m-K)		0.4	ASTM D5470			
<b>THERMAL PERFORMANCE VS. PRESSURE</b>						
Initial Assembly Pressure (psi for 5 seconds)		10	25	50	100	200
TO-220 Thermal Performance (°C/W)		5.48	5.47	5.15	5.05	5.00
Thermal Impedance (°C-in. <sup>2</sup> /W) <sup>(1)</sup>		0.83	0.82	0.81	0.80	0.79
1) The ASTM D5470 test fixture was used. The recorded value includes interfacial thermal resistance. These values are provided for reference only. Actual application performance is directly related to the surface roughness, flatness and pressure applied.						

**Shelf Life:** The double-sided pressure sensitive adhesive used in BOND-PLY products requires the use of dual liners to protect the surfaces from contaminants. Henkel recommends a 6-month shelf life at a maximum continuous storage temperature of 35°C, or 3-month shelf life at a maximum continuous storage temperature of 45°C, for maintenance of controlled adhesion to the liner. The shelf life of the BOND-PLY material, without consideration of liner adhesion (which is often not critical for manual assembly processing), is recommended at 12 months from date of manufacture at a maximum continuous storage temperature of 60°C.

## Building a Part Number

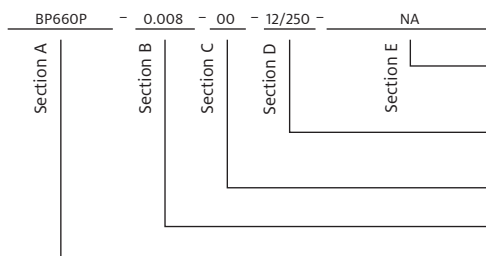

## Standard Options

## ◀ example

NA = Selected standard option. If not selecting a standard option, insert company name, drawing number, and revision level.

1212 = 12" x 12" Sheets, 12/250 = 12" x 250' rolls or 00 = custom configuration

00 = No adhesive

Standard thicknesses available: 0.008"

BP660P = BOND-PLY 660P Material

Note: To build a part number, go to [www.bergquistcompany.com/Part\\_Number\\_Builder.php](http://www.bergquistcompany.com/Part_Number_Builder.php).



# BOND-PLY 800

## Thermally Conductive, Fiberglass-Reinforced Pressure Sensitive Adhesive Tape

### Features and Benefits

- Thermal impedance: 0.60°C-in.<sup>2</sup>/W (@ 50 psi)
- High bond strength to most epoxies and metals
- Double-sided, pressure sensitive adhesive tape
- High performance, thermally conductive acrylic adhesive
- More cost-effective than heat-cure adhesive, screw mounting or clip mounting



BOND-PLY 800 is a thermally conductive, electrically isolating double-sided tape.

BOND-PLY 800 is used in lighting applications that require thermal transfer and electric isolation. High bond strengths obtained at ambient temperature lead to significant processing cost savings in labor, materials and throughput due to the elimination of mechanical fasteners and high temperature curing.

### Typical Applications Include:

- Mount LED assembly to troffer housing
- Mount LED assembly to heat sink
- Mount heat spreader onto power converter PCB or onto motor control PCB
- Mount heat sink to BGA graphic processor or drive processor

### Configurations Available:

- Sheet form, roll form and die-cut parts

### TYPICAL PROPERTIES OF BOND-PLY 800

PROPERTY	IMPERIAL VALUE	METRIC VALUE	TEST METHOD		
Color	Gray	Gray	Visual		
Reinforcement Carrier	Fiberglass	Fiberglass	—		
Thickness (in.) / (mm)	0.005, 0.008	0.127, 0.203	ASTM D374		
Elongation (% , 45° to Warp & Fill)	70	70	ASTM D412		
Tensile Strength (psi) / (mPa)	1,500	10	ASTM D412		
CTE (um/m-°C), -40°C to +125°C	600	600	ASTM D3386		
Continuous Use Temp. (°F) / (°C)	-40 to 257	-40 to 125	—		
<b>ADHESION</b>					
Lap Shear @ RT (psi) / (mPa) <sup>(1)</sup>	150	1.0	ASTM D1002		
<b>ELECTRICAL</b>		<b>VALUE</b>	<b>TEST METHOD</b>		
Dielectric Breakdown Voltage (Vac.), 0.005		4,000	ASTM D149		
Dielectric Breakdown Voltage (Vac.), 0.008		6,000	ASTM D149		
Dielectric Constant (1,000 Hz)		4.0	ASTM D150		
Volume Resistivity (Ohmmeter)		10 <sup>11</sup>	ASTM D257		
Flame Rating		V-O	UL 94		
<b>THERMAL</b>					
Thermal Conductivity (W/m-K)		0.8	ASTM D5470		
<b>THERMAL PERFORMANCE VS. PRESSURE</b>					
Initial Assembly Pressure (psi for 5 seconds)	10	25	50	100	200
TO-220 Thermal Performance (°C/W), 0.005	5.0	5.0	4.8	4.3	4.2
TO-220 Thermal Performance (°C/W), 0.008	6.2	6.0	5.6	5.3	5.2
Thermal Impedance (°C-in. <sup>2</sup> /W), 0.005 <sup>(2)</sup>	0.63	0.62	0.60	0.58	0.57
Thermal Impedance (°C-n. <sup>2</sup> /W), 0.008 <sup>(2)</sup>	0.78	0.74	0.72	0.71	0.71

1) Tested per ASTM D1002 with aluminum lap shear samples, 75 psi applied for 5 seconds then pressure removed. 0.5 square inch BOND-PLY 800 sample.  
2) The ASTM D5470 test fixture was used. The recorded value includes interfacial thermal resistance. These values are provided for reference only. Actual application performance is directly related to the surface roughness, flatness and pressure applied.

### Building a Part Number

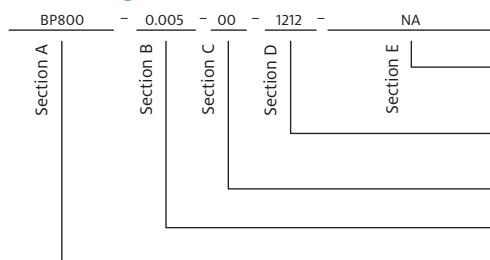

### Standard Options

#### ◀ example

NA = Selected standard option. If not selecting a standard option, insert company name, drawing number, and revision level.

1212 = 12" x 12" sheets, 12250 = 12" x 250' rolls or 00 = custom configuration

00 = Standard double-sided adhesive

Standard thicknesses available: 0.005", 0.008"

BP800 = BOND-PLY 800 Material

Note: To build a part number, go to [www.bergquistcompany.com/Part\\_Number\\_Builder.php](http://www.bergquistcompany.com/Part_Number_Builder.php).

# BOND-PLY LMS-HD

## Laminate Material – Silicone, High Durability, Optional Lamination Methods

### Features and Benefits

- TO-220 thermal performance: 2.3°C/W, initial pressure only lamination
- Exceptional dielectric strength
- Very low interfacial resistance
- 200 psi adhesion strength
- 200 psi adhesion strength
- Continuous use of -60 to 180°C
- Eliminates mechanical fasteners

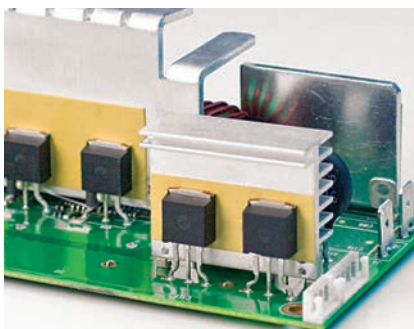

BOND-PLY LMS-HD is a thermally conductive heat curable laminate material. The product consists of a high performance thermally conductive low modulus silicone compound coated on a cured core, and double lined with protective films. The low modulus silicone design effectively absorbs mechanical stresses induced by assembly-level CTE mismatch, shock and vibration while providing exceptional thermal performance (vs. PSA technologies) and long-term integrity. BOND-PLY LMS-HD will typically be used for structurally adhering power components and PCBs to a heat sink.

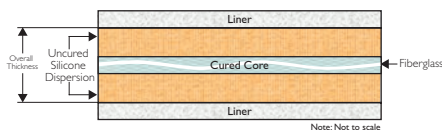

### Typical Applications Include:

- Discrete semiconductor packages bonded to heat spreader or heat sink

### TYPICAL PROPERTIES OF BOND-PLY LMS-HD

PROPERTY	IMPERIAL VALUE	METRIC VALUE	TEST METHOD
Color	Yellow	Yellow	Visual
Reinforcement Carrier	Fiberglass	Fiberglass	—
Thickness (in.) / (mm)	0.010 to 0.018	0.254 to 0.457	ASTM D374
Continuous Use Temp. (°F) / (°C)	-76 to 356	-60 to 180	—
<b>ADHESION</b>			
Lap Shear @ RT (psi) / (mPa)	200	1.4	ASTM D1002
<b>ELECTRICAL</b>		<b>VALUE</b>	<b>TEST METHOD</b>
Breakdown Voltage, Sheet (Vac.) <sup>(1)</sup>		5,000	ASTM D149
Breakdown Voltage, Laminated (Vac.) <sup>(2)</sup>		4,000	ASTM D149
Dielectric Constant (1,000 Hz)		5.0	ASTM D150
Volume Resistivity (Ohmmeter)		10 <sup>11</sup>	ASTM D257
Flame Rating		V-O	UL 94
<b>THERMAL</b>			
Post-Cured Thermal Conductivity (W/m-K) <sup>(3)</sup>		1.4	ASTM D5470
<b>THERMAL IMPEDANCE VS. LAMINATION METHOD</b>			
Lamination Pressure (75 psi) <sup>(4)</sup>	Constant		IPO
TO-220 Thermal Performance (°C/W)		2.1	2.3
<b>CURE SCHEDULE</b>			
Cure @ 125°C (mins.) <sup>(5)</sup>	30		30
Cure @ 160°C (mins.) <sup>(5)</sup>	6		6

1) The ASTM D149 test method on cured LMS-HD material. No pressure was applied to the LMS-HD during the cure cycle.  
 2) A 1/2 in. diameter probe was laminated with LMS-HD to a 2 in. X 2 in. plate at 200 psi for 30 seconds, then cured with no pressure at 160°C for 6 minutes. The cured assembly was then tested per ASTM D149. This LMS-HD sample resembles a typical lamination application.  
 3) The ASTM D5470 (Bergquist Modified) test procedure was used on post-cured LMS-HD material. The recorded value includes interfacial thermal resistance. These values are given for customer reference only.  
 4) TO-220 Thermal Performance testing, per The Bergquist RD2010 specification for laminates, was completed on laminated TO-220 assemblies. Lamination was completed at 75 psi for 30 seconds for "IPO" (Initial Pressure Only) and at a constant 75 psi during the lamination and curing process for "Constant." No additional pressure was applied during TO-220 thermal performance testing.  
 5) Cure Schedule – time after cure temperature is achieved at the interface. Ramp time is application dependent.

### Configurations Available:

- Roll form
- Die-cut parts
- Sheet form

**Shelf Life:** BOND-PLY LMS-HD is a heat-cured material and should be stored in temperature controlled conditions. The recommended storage temperature range of 5-25°C should be used to maintain optimum characteristics for a 5-month shelf life.

### Building a Part Number

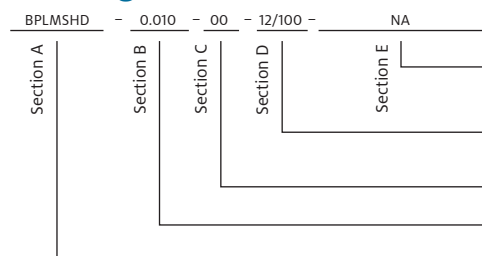

### Standard Options

« example

NA = Selected standard option. If not selecting a standard option, insert company name, drawing number, and revision level.

1212 = 12" x 12" Sheets, 12/100 = 12" x 100' rolls

00 = No adhesive

Standard thicknesses available: 0.010", 0.012", 0.016", 0.018"

BPLMSHD = BOND-PLY LMS-HD Material

Note: To build a part number, go to [www.bergquistcompany.com/Part\\_Number\\_Builder.php](http://www.bergquistcompany.com/Part_Number_Builder.php).

# LIQUI-BOND EA 1805 (Two-Part)

## Thermally Conductive, Liquid Epoxy Adhesive

### Features and Benefits

- Room temperature cure
- Room temperature storage
- Thermal Conductivity: 1.8 W/m-K
- Eliminates need for mechanical fasteners
- Maintains structural bond in severe environment applications
- Excellent chemical and mechanical stability



LIQUI-BOND EA 1805 is a two-component, epoxy based, liquid-dispensable adhesive. LIQUI-BOND EA 1805 has a thermal conductivity of 1.8 W/mK.

LIQUI-BOND EA 1805 will be supplied in a two-component format, and refrigeration is not required.

LIQUI-BOND EA 1805 has a high bond strength with room temperature cure that can be accelerated with additional heat. The high bond strength eliminates the need for fasteners and maintains structural bond in severe environments. Recommended usage is filling any surface irregularities between heat sources and heat spreaders of similar CTE. LIQUI-BOND EA 1805 is thixotropic and will remain in place during dispensing, and the material will flow easily under minimal pressure, resulting in thin bond lines and very low stress placed on fragile components during assembly.

### TYPICAL PROPERTIES OF LIQUI-BOND EA 1805

PROPERTY	IMPERIAL VALUE	METRIC VALUE	TEST METHOD
Color / Part A	Grey	Grey	Visual
Color / Part B	Pale Yellow	Pale Yellow	Visual
Viscosity / Part A, High Shear (Pa-s) <sup>(1)</sup>	60	60	ASTM D2196
Viscosity / Part B, High Shear (Pa-s) <sup>(1)</sup>	62	62	ASTM D2196
Density (g/cc)	2.7	2.7	ASTM D792
Mix Ratio By Volume	1:1	1:1	—
Shelf Life @ 25°C (months)	6	6	—
<b>PROPERTY AS CURED</b>			
Hardness (Shore D) <sup>(2)</sup>	90	90	ASTM D2240
Continuous Use Temp. (°F) / (°C)	-40 to 257	-40 to 125	—
Shear Strength (psi) / (mPa) <sup>(3)</sup>	450	3.1	ASTM D1002
<b>ELECTRICAL AS CURED</b>			
Dielectric Strength (V/mil) / (V/mm)	250	10,000	ASTM D149
Dielectric Constant (1,000 Hz)	7.5	7.5	ASTM D150
Volume Resistivity (Ohmmeter)	10 <sup>14</sup>	10 <sup>14</sup>	ASTM D257
Flame Rating	V-O	V-O	UL 94
<b>THERMAL AS CURED</b>			
Thermal Conductivity (W/m-K)	1.8	1.8	ASTM D5470
cure schedule			
Cure @ 25°C (hrs.)	10	10	—
Cure @ 125°C (mins.) <sup>(4)</sup>	10	10	—

1) Capillary Viscosity, 200/sec., Part A and B measured separately.  
 2) Thirty-second delay value Shore D hardness scale.  
 3) Al to Al, cured at room temperature  
 4) 90% cure cycle - time after cure temperature is achieved at the interface. Ramp time is application dependent.

### Typical Applications:

- LED lighting
- Power supplies
- Discrete component to heat spreader
- Automotive lighting
- White goods

### Configurations Available:

- Supplied in cartridge or kit form

### Building a Part Number Standard Options

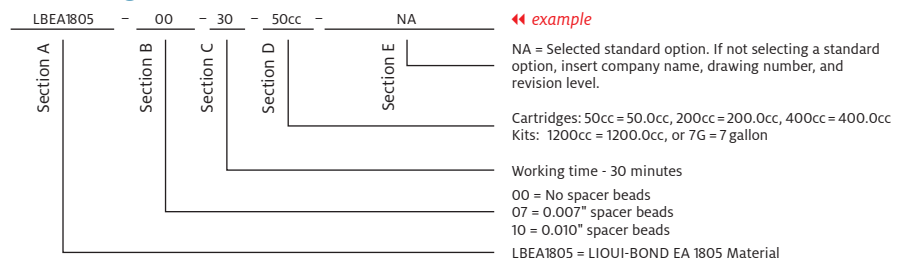

Note: To build a part number, go to [www.bergquistcompany.com/Part\\_Number\\_Builder.php](http://www.bergquistcompany.com/Part_Number_Builder.php).

# LIQUI-BOND SA 1000 (One-Part)

## Thermally Conductive, Liquid Silicone Adhesive

### Features and Benefits

- High thermal performance
- Eliminates need for mechanical fasteners
- Low viscosity for ease of screening or stenciling
- Can achieve a very thin bond line
- Mechanical and chemical stability
- Maintains structural bond in severe environment applications
- Heat cure

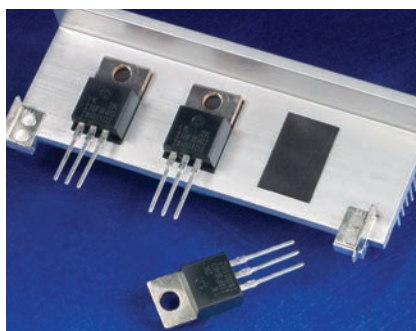

LIQUI-BOND SA 1000 is a thermally conductive, one-part liquid silicone adhesive with a low viscosity for easy screenability. LIQUI-BOND SA 1000 features a high thermal performance and maintains its structure even in severe environment applications.

LIQUI-BOND SA 1000 features excellent low and high temperature mechanical and chemical stability. The material's mild elastic properties assist in relieving CTE stresses during thermal cycling. LIQUI-BOND SA 1000 contains no cure by-products, cures at elevated temperatures and requires refrigeration storage at 10°C. The material is available in both tube and mid-sized container forms.

### TYPICAL PROPERTIES OF LIQUI-BOND SA 1000

PROPERTY AS SUPPLIED	IMPERIAL VALUE	METRIC VALUE	TEST METHOD
Color	Black	Black	Visual
Viscosity (cPs) <sup>(1)</sup>	125,000	125,000	ASTM D2196
Density (g/cc)	2.4	2.4	ASTM D792
Shelf Life @ 10°C (months)	6	6	—
PROPERTY AS CURED – PHYSICAL			
Hardness (Shore A)	75	75	ASTM D2240
Continuous Use Temp. (°F) / (°C)	-76 to 392	-60 to 200	—
Shear Strength (psi) / (mPa)	200	1.4	ASTM D1002
PROPERTY AS CURED – ELECTRICAL			
Dielectric Strength (V/mil) / (V/mm)	250	10,000	ASTM D149
Dielectric Constant (1,000 Hz)	5.5	5.5	ASTM D150
Volume Resistivity (Ohmmeter)	10 <sup>10</sup>	10 <sup>10</sup>	ASTM D257
Flame Rating	V-O	V-O	UL 94
PROPERTY AS CURED – THERMAL			
Thermal Conductivity (W/m-K)	1.0	1.0	ASTM D5470
CURE SCHEDULE			
Pot Life @ 25°C (hrs.) <sup>(2)</sup>	10	10	—
Cure @ 125°C (mins.) <sup>(3)</sup>	20	20	—
Cure @ 150°C (mins.) <sup>(3)</sup>	10	10	—

1) Brookfield RV, Heli-path, Spindle TF @ 20 rpm, 25°C.  
 2) Based on 1/8 in. diameter bead.  
 3) Cure Schedule - time after cure temperature is achieved at the interface. Ramp time is application dependent.

### Typical Applications Include:

- PCBA to housing
- Discrete component to heat spreader

### Configurations Available:

- With or without glass beads

### Building a Part Number

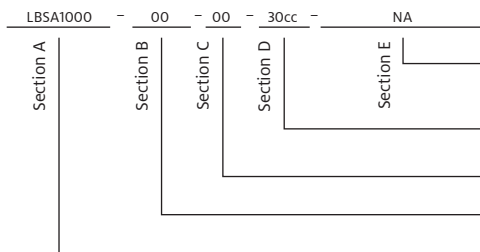

### Standard Options

◀ **example**

NA = Selected standard option. If not selecting a standard option, insert company name, drawing number, and revision level.

Cartridges: 30cc = 30.0cc, 600cc = 600.0cc (ml)  
 Pail: 0.85G = 0.85-gallon, 5G = 5-gallon

00 = No adhesive  
 00 = No spacer beads  
 07 = 0.007" spacer beads

LBSA1000 = LIQUI-BOND SA 1000 Liquid Adhesive Material

Note: To build a part number, go to [www.bergquistcompany.com/Part\\_Number\\_Builder.php](http://www.bergquistcompany.com/Part_Number_Builder.php).

# LIQUI-BOND SA 1800 (One-Part)

## Thermally Conductive, Liquid Silicone Adhesive

### Features and Benefits

- High thermal conductivity: 1.8 W/m-K
- Eliminates need for mechanical fasteners
- Low viscosity for ease of screening or stenciling
- Maintains structural bond in severe environment applications
- Heat cure

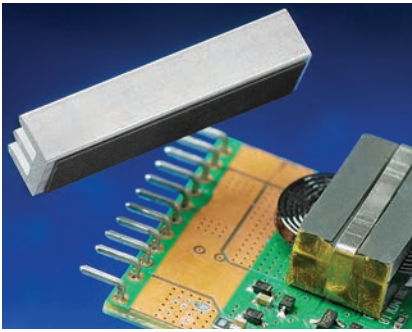

LIQUI-BOND SA 1800 is a high performance, liquid silicone adhesive that cures to a solid bonding elastomer. The adhesive is supplied as a one-part liquid component, offered in a tube or mid-size container.

LIQUI-BOND SA 1800 features a combination of high thermal conductivity with a low viscosity which allows for ease of screen or stencil application. This material is also ideal for high volume automated pattern dispensing. LIQUI-BOND SA 1800's low viscosity allows the material to achieve a very thin bond line, producing excellent thermal performance and a high shear strength.

The mild elastic properties of LIQUI-BOND SA 1800 assist in relieving CTE stresses during thermal cycling. The material cures at elevated temperatures and requires refrigeration storage at 10°C. LIQUI-BOND SA 1800 is available with optional glass beads to provide a consistent stand-off and ensure dielectric integrity.

### TYPICAL PROPERTIES OF LIQUI-BOND SA 1800

PROPERTY AS SUPPLIED	IMPERIAL VALUE	METRIC VALUE	TEST METHOD
Color	Black	Black	Visual
Viscosity (cPs) <sup>(1)</sup>	125,000	125,000	ASTM D2196
Density (g/cc)	2.8	2.8	ASTM D792
Shelf Life @ 10°C (months)	6	6	—
<b>PROPERTY AS CURED – PHYSICAL</b>			
Hardness (Shore A)	80	80	ASTM D2240
Continuous Use Temp. (°F) / (°C)	-76 to 392	-60 to 200	—
Shear Strength (psi) / (mPa)	200	1.4	ASTM D1002
<b>PROPERTY AS CURED – ELECTRICAL</b>			
Dielectric Strength (V/mil) / (V/mm)	250	10,000	ASTM D149
Dielectric Constant (1,000 Hz)	6.0	6.0	ASTM D150
Volume Resistivity (Ohmmeter)	10 <sup>11</sup>	10 <sup>11</sup>	ASTM D257
Flame Rating	V-O	V-O	UL 94
<b>PROPERTY AS CURED – THERMAL</b>			
Thermal Conductivity (W/m-K)	1.8	1.8	ASTM D5470
<b>CURE SCHEDULE</b>			
Pot Life @ 25°C (hrs.) <sup>(2)</sup>	10	10	—
Cure @ 125°C (mins.) <sup>(3)</sup>	20	20	—
Cure @ 150°C (mind.) <sup>(3)</sup>	10	10	—

1) Brookfield RV, Heli-path, Spindle TF @ 20 rpm, 25°C.  
 2) Based on 1/8 in. diameter bead.  
 3) Cure Schedule - time after cure temperature is achieved at the interface. Ramp time is application dependent.

### Typical Applications Include:

- PCB assembly to housing
- Discrete component to heat spreader

### Configurations Available:

- With or without glass beads

### Building a Part Number

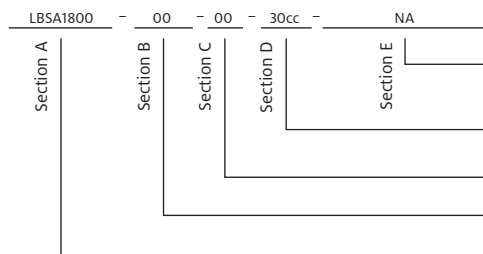

### Standard Options

#### ◀ example

NA = Selected standard option. If not selecting a standard option, insert company name, drawing number, and revision level.

Cartridges: 30cc = 30.0cc, 600cc = 600.0cc (ml)  
 Pail: 0.85G = 0.85-gallon, 5G = 5-gallon

00 = No adhesive

00 = No spacer beads  
 07 = 0.007" spacer beads

LBSA1800 = LIQUI-BOND SA 1800 (One-Part)  
 Liquid Adhesive Material

Note: To build a part number, go to [www.bergquistcompany.com/Part\\_Number\\_Builder.php](http://www.bergquistcompany.com/Part_Number_Builder.php).

# LIQUI-BOND SA 2000 (One-Part)

## Thermally Conductive, Liquid Silicone Adhesive

### Features and Benefits

- High thermal conductivity: 2.0 W/m-K
- Eliminates need for mechanical fasteners
- One-part formulation for easy dispensing
- Mechanical and chemical stability
- Maintains structural bond in severe environment applications
- Heat cure

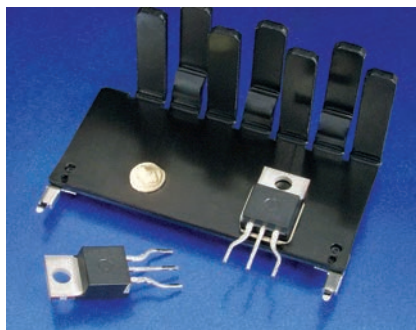

LIQUI-BOND SA 2000 is a high performance, thermally conductive silicone adhesive that cures to a solid bonding elastomer. LIQUI-BOND SA 2000 is supplied as a one-part liquid component, in either tube or mid-sized container form.

LIQUI-BOND SA 2000 features excellent low and high-temperature mechanical and chemical stability. The material's mild elastic properties assist in relieving CTE stresses during thermal cycling. LIQUI-BOND SA 2000 cures at elevated temperatures and requires refrigeration storage at 10°C.

### TYPICAL PROPERTIES OF LIQUI-BOND SA 2000

PROPERTY AS SUPPLIED	IMPERIAL VALUE	METRIC VALUE	TEST METHOD
Color	Yellow	Yellow	Visual
Viscosity (cPs) <sup>(1)</sup>	200,000	200,000	ASTM D2196
Density (g/cc)	2.4	2.4	ASTM D792
Shelf Life @ 10°C (months)	6	6	—
PROPERTY AS CURED – PHYSICAL			
Hardness (Shore A)	80	80	ASTM D2240
Continuous Use Temp. (°F) / (°C)	-76 to 392	-60 to 200	—
Shear Strength (psi) / (mPa)	200	1.4	ASTM D1002
PROPERTY AS CURED – ELECTRICAL			
Dielectric Strength (V/mil) / (V/mm)	250	10,000	ASTM D149
Dielectric Constant (1,000 Hz)	6.0	6.0	ASTM D150
Volume Resistivity (Ohmmeter)	10 <sup>11</sup>	10 <sup>11</sup>	ASTM D257
Flame Rating	V-O	V-O	UL 94
PROPERTY AS CURED – THERMAL			
Thermal Conductivity (W/m-K)	2.0	2.0	ASTM D5470
CURE SCHEDULE			
Pot Life @ 25°C (hrs.) <sup>(2)</sup>	24	24	—
Cure @ 125°C (mins.) <sup>(3)</sup>	20	20	—
Cure @ 150°C (mins.) <sup>(3)</sup>	10	10	—

<sup>1)</sup> Brookfield RV, Heli-path, Spindle TF @ 20 rpm, 25°C.  
<sup>2)</sup> Based on 1/8 in. diameter bead.  
<sup>3)</sup> Cure Schedule - time after cure temperature is achieved at the interface. Ramp time is application dependent.

### Typical Applications Include:

- PCBA to housing
- Discrete component to heat spreader

### Configurations Available:

- With or without glass beads

### Building a Part Number

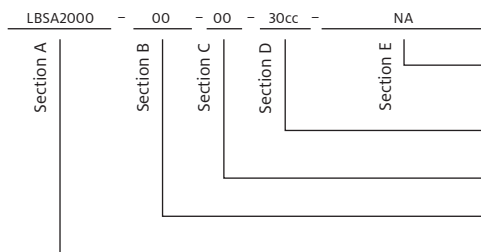

### Standard Options

◀ example

NA = Selected standard option. If not selecting a standard option, insert company name, drawing number, and revision level.

Cartridges: 30cc = 30.0cc, 600cc = 600.0cc (ml)  
 Pail: 0.85G = 0.85-gallon, 5G = 5-gallon

00 = No adhesive

00 = No spacer beads  
 07 = 0.007" spacer beads

LBSA2000 = LIQUI-BOND SA 2000 Liquid Adhesive Material

Note: To build a part number, go to [www.bergquistcompany.com/Part\\_Number\\_Builder.php](http://www.bergquistcompany.com/Part_Number_Builder.php).



# LIQUI-BOND SA 3505 (Two-Part)

## Thermally Conductive, Liquid Silicone Adhesive

### Features and Benefits

- Thermal conductivity: 3.5 W/m-K
- Eliminates need for mechanical fasteners
- Room temperature storage
- Maintains structural bond in severe environment applications
- Heat cure

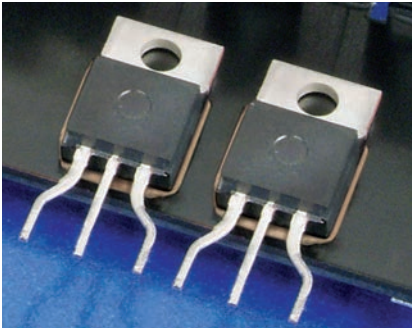

LIQUI-BOND SA 3505 is a high performance, thermally conductive, liquid adhesive. This material is supplied as a two-part material and requires no refrigeration.

The mixed material cures at elevated temperatures. As cured, LIQUI-BOND SA 3505 provides a strong bonding, form-in-place elastomer. The material's mild elastic properties assist in relieving CTE stresses during thermal cycling.

Liquid dispensed thermal materials offer infinite thickness variations and impart little to no stress on sensitive components during assembly. LIQUI-BOND SA 3505 is available with optional glass spacer beads to provide a consistent bond line and ensure dielectric integrity.

TYPICAL PROPERTIES OF LIQUI-BOND SA 3505			
PROPERTY	IMPERIAL VALUE	METRIC VALUE	TEST METHOD
Color / Part A	Brown	Brown	Visual
Color / Part B	Light Grey	Light Grey	Visual
Viscosity / Part A, High Shear (Pa-s) <sup>(1)</sup>	45	45	ASTM D5099
Viscosity / Part B, High Shear (Pa-s) <sup>(1)</sup>	30	30	ASTM D5099
Density (g/cc)	2.9	2.9	ASTM D792
Mix Ratio	1:1	1:1	—
Shelf Life @ 25°C (months)	6	6	—
PROPERTY AS CURED			
Color	Light Brown	Light Brown	Visual
Hardness (Shore A) <sup>(2)</sup>	90	90	ASTM D2240
Continuous Use Temp. (°F) / (°C)	-76 to 392	-60 to 200	—
Shear Strength (psi) / (mPa)	450	3.15	ASTM D1002
ELECTRICAL AS CURED			
Dielectric Strength (V/mil) / (V/mm)	250	10,000	ASTM D149
Dielectric Constant (1,000 Hz)	6.9	6.9	ASTM D150
Volume Resistivity (Ohmmeter)	10 <sup>10</sup>	10 <sup>10</sup>	ASTM D257
Flame Rating	V-O	V-O	UL 94
THERMAL AS CURED			
Thermal Conductivity (W/m-K)	3.5	3.5	ASTM D5470
CURE SCHEDULE			
Pot Life @ 25°C <sup>(3)</sup>	240 mins. (4 hrs.)	240 mins. (4 hrs.)	—
Cure @ 125°C (mins.) <sup>(4)</sup>	20	20	—
Cure @ 150°C (mins.) <sup>(4)</sup>	10	10	—

1) Capillary Viscosity, 600/sec., Part A and B measured separately.  
 2) Thirty-second delay value Shore A hardness scale.  
 3) Based on 1/8 in. diameter bead.  
 4) Cure schedule — time after cure temperature is achieved at the interface. Ramp time is application dependent.

### Typical Applications:

- Power supplies
- Discrete component to heat spreader
- PCBA to housing

### Configurations Available:

- Supplied in cartridge or kit form

### Building a Part Number Standard Options

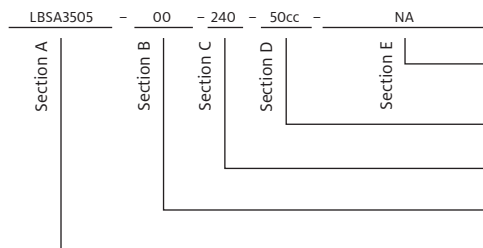

◀ example

NA = Selected standard option. If not selecting a standard option, insert company name, drawing number, and revision level.

Cartridges: 50cc = 50.0cc, 400cc = 400.0cc  
 Kits: 1200cc = 1200.0cc, or 10G = 10 gallon

Pot Life: 240 = 240 minutes

00 = No spacer beads  
 07 = 0.007" spacer beads  
 10 = 0.010" spacer beads

LBSA3505 = LIQUI-BOND SA 3505 Material

Note: To build a part number, go to [www.bergquistcompany.com/Part\\_Number\\_Builder.php](http://www.bergquistcompany.com/Part_Number_Builder.php).

# SIL PAD Configurations

## Imperial Measurements

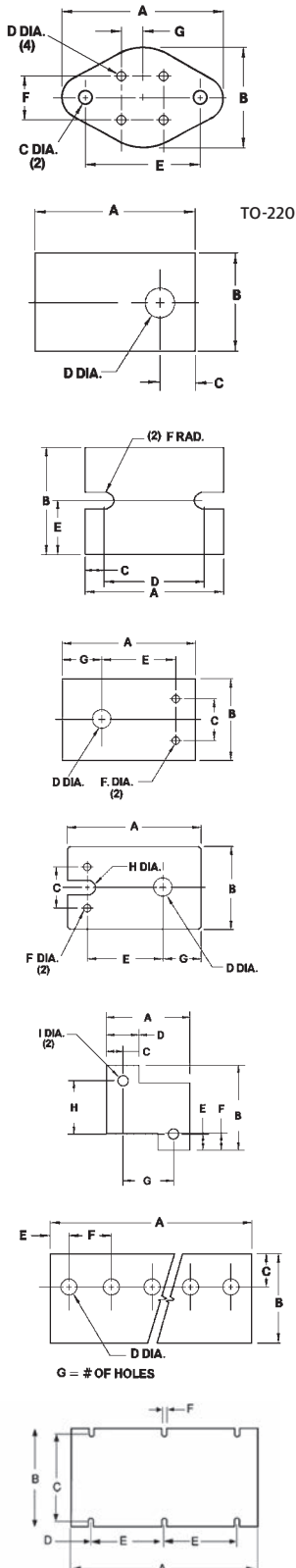

4 LEAD TO-66	PART NUMBER SUFFIX	"A"	"B"	"C"	"D"	"E"	"F"	"G"
	-84	1.312	.762	.140	.062	.960	.200	.100

PLASTIC POWER	PART NUMBER SUFFIX	DIMENSIONS				PLASTIC POWER	PART NUMBER SUFFIX	DIMENSIONS			
		"A"	"B"	"C"	"D"			"A"	"B"	"C"	"D"
Various	-35	.710	.500	.160	.141	Various	-104	1.000	.750	.300	.140
(Clip Mount)	-43	.750	.500			Various	-107	.810	.910	.170	.147
	TO-126	.437	.312	.140	.093	Various	-110	.984	.787		
	Various	.687	.562	.218	.125	Various	-114	.827	.945	.197	.150
	Various	.855	.630	.230	.093	Various	-116	.855	.630	.228	.122
	TO-220	.750	.500	.187	.147	Various	-117	.827	.709	.256	.126
	TO-202	.610	.560	.245	.125	Various	-118	.748	.551	.217	.126
	Various	.855	.562	.218	.125	Various	-119	.437	.311	.142	.110
	TO-220	.750	.500	.187	.125	Various	-120	.728	.472	.157	.098
	TO-126	.437	.312	.140	.122	TO-3P	-122	1.140	.810	.355	.147
	Various	.750	.410	.225	.156	Various	-126	.945	.748	.256	.162
	TO-220	.750	.600	.240	.150	Various	-128	.984	1.654	.315	.157
	Various	.750	.600	.240	.115	Various	-131	.709	.512	.177	.122
	Various	.500	.385	.170	.120	Various	-132	.472	.315	.157	.126
	TO-218	1.125	.625	.200	.145	Various	-133	.866	.709	.256	.126
	Various	1.410	.810	.355	.147	Various	-134	.945	.709	.228	.126
	Various	.860	.740	.200	.160	Various	-136	1.250	1.000		
	Various	.866	.650	.217	.142	Various	-137	1.250	1.000	.258	.127
	Various	.750	.800	.150	.160	Various	-138	1.250	1.000	.258	.148

POWER MODULE	PART NUMBER SUFFIX	DIMENSIONS					
		"A"	"B"	"C"	"D"	"E"	"F"
	-67	1.500	.900	.150	1.200	.450	.075
	-101	2.500	2.000	.344	1.812	1.000	.156

PLASTIC POWER	PART NUMBER SUFFIX	DIMENSIONS						
		"A"	"B"	"C"	"D"	"E"	"F"	"G"
	-57	.910	.500	.200	.125	.580	.046	.265
	-89	.983	.750	.432	.156	.665	.101	.217

PLASTIC POWER	PART NUMBER SUFFIX	DIMENSIONS							
		"A"	"B"	"C"	"D"	"E"	"F"	"G"	"H"
	-66	1.000	.500	.200	.141	.626	.046	.219	.032

POWER RESISTORS	PART NUMBER SUFFIX	DIMENSIONS									
		"A"	"B"	"C"	"D"	"E"	"F"	"G"	"H"	"I"	
	RH-25	.94	1.187	1.205	.234	.469	.212	.156	.719	.781	.140
	RH-50	.95	2.093	1.265	.265	.530	.210	.255	1.563	.845	.140
	RH-5	.96	.725	.771	.140	.280	.140	.156	.445	.491	.093
	RH-10	.97	.805	.890	.127	.250	.130	.190	.551	.630	.121
	RH-25	.98	1.150	1.180	.231	.425	.190	.270	.688	.800	.147
	RH-50	.99	1.965	1.236	.198	.404	.132	.263	1.569	.972	.130

TO-220 MULTIPLES	PART NUMBER SUFFIX	DIMENSIONS							# OF HOLES
		"A"	"B"	"C"	"D"	"E"	"F"		
2 Parts	-34	1.000	.750	.187	.125	.250	.500	2	
3 Parts	-36	1.500	.750	.187	.125	.250	.500	3	
	-37	2.000	.750	.187	.125	.250	.500	4	
	-38	2.500	.750	.187	.125	.250	.500	5	
	-39	3.000	.750	.187	.125	.250	.500	6	
	-40	3.500	.750	.187	.125	.250	.500	7	
	-41	4.000	.750	.187	.125	.250	.500	8	

POWER MODULE	PART NUMBER SUFFIX	DIMENSIONS					
		"A"	"B"	"C"	"D"	"E"	"F"
	-108	4.600	2.400	2.125	.500	1.800	.125
	-140	4.598	2.402	2.098	0.500	1.799	0.150
	-141	2.279	2.402	2.102	0.488	0.650	0.150
	-142	2.280	1.450	1.270	0.490	0.650	0.130

# SIL PAD Configurations

## Imperial Measurements

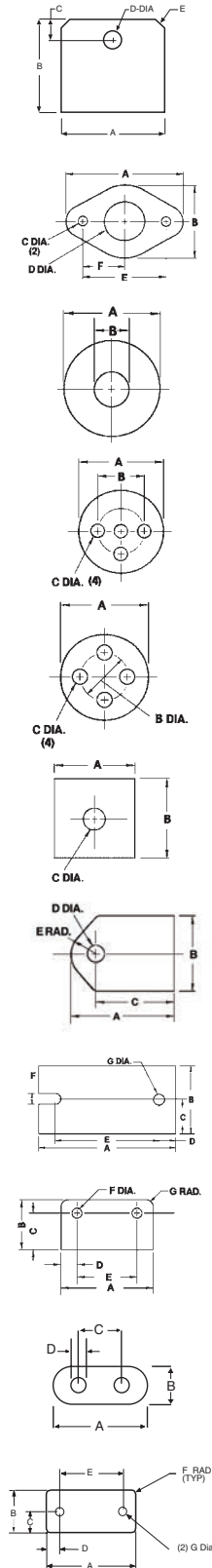

MULTIWATT	PART NUMBER SUFFIX	DIMENSIONS				
		"A"	"B"	"C"	"D"	"E"
	-124	.872	.790	.160	.148	.118 x 45°
	-125	.866	.787	.157	.154	.079 x 45°

MULTI-LEAD TO-66	PART NUMBER SUFFIX	DIMENSIONS					
		"A"	"B"	"C"	"D"	"E"	"F"
	-93	1.350	.800	.140	.400	.960	.480

DIODE WASHER	PART NUMBER SUFFIX	DIMENSIONS		DIODE WASHER	PART NUMBER SUFFIX	DIMENSIONS	
		"A"	"B"			"A"	"B"
Various	-19	.510	.140	Various	-75	.360	.260
DO-4	-20	.510	.200	Various	-76	.750	.125
DO-5	-21	.800	.260	Various	-77	.800	.190
DO-4 (oversized)	-22	.625	.200	DO-8	-78	.875	.313
DO-5 (oversized)	-25	1.000	.260	Various	-79	1.180	.515
Various	-26	.812	.145	Various	-80	1.250	.380
Various	-27	.812	.115	Various	-81	1.500	.200
Various	-28	1.000	.140	Various	-82	.512	.161
Various	-32	1.500	.500	Various	-111	.591	.217

TO-36	PART NUMBER SUFFIX	DIMENSIONS		
		"A"	"B"	"C"
	-08	1.063	.690	.190

SMALL POWER DEVICES	PART NUMBER SUFFIX	DIMENSIONS		
		"A"	"B"	"C"
TO-5, 3 Holes	-09	.360	.200	.040
TO-18, 3 Holes	-12	.250	.100	.036
TO-18, 4 Holes	-13	.250	.100	.036
TO-5, 4 Holes	-33	.360	.200	.040
TO-5, 3 Holes	-44	.390	.200	.040
TO-5, 4 Holes	-45	.390	.200	.040

RECTIFIER	PART NUMBER SUFFIX	DIMENSIONS		
		"A"	"B"	"C"
	-46	1.250	1.250	.200
	-47	1.125	1.125	.140
	-48	1.000	1.000	.187

TIP PACKAGES	PART NUMBER SUFFIX	DIMENSIONS				
		"A"	"B"	"C"	"D"	"E"
Clip Mount	-42	.984	.787			.205
TIP-36 Plastic Tip	-53	.865	.650	.650	.140	.205
TO-3P	-65	1.260	.787	.984	.142	.205
Plastic Clip	-73	.984	.787	.708	.142	.205

POWER MODULE	PART NUMBER SUFFIX	DIMENSIONS						
		"A"	"B"	"C"	"D"	"E"	"F"	"G"
	-100	2.510	1.260	.630	.305	1.900	.205	.205
	-123	1.614	1.102	.551	.157	1.220	.118	.118

SIP PACKAGE	PART NUMBER SUFFIX	DIMENSIONS						
		"A"	"B"	"C"	"D"	"E"	"F"	"G"
	-105	1.450	.838	.612	.245	.960	.170	.120

QUARTZ	PART NUMBER SUFFIX	DIMENSIONS			
		"A"	"B"	"C"	"D"
	-115	.472	.197	.193	.031

POWER MODULE	PART NUMBER SUFFIX	DIMENSIONS						
		"A"	"B"	"C"	"D"	"E"	"F"	"G"
	-109	1.350	.642	.321	.195	.960	.060	.125

# SIL PAD Configurations

## Imperial Measurements

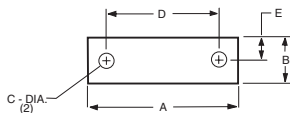
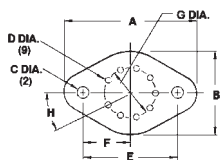
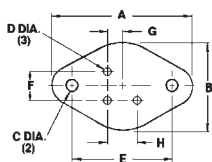
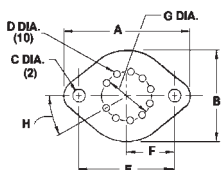
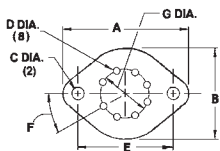
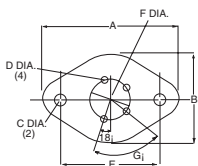
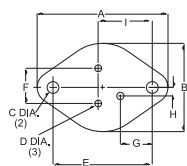
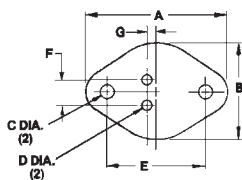

TO-3 & TO-66								
STYLE	PART NUMBER SUFFIX	DIMENSIONS						
		"A"	"B"	"C"	"D"	"E"	"F"	"G"
	-02	1.780	1.250	.140	.093	1.187	.430	.072
	-03	1.563	1.050	.140	.080	1.187	.430	.072
	-04	1.650	1.140	.122	.062	1.187	.430	.072
	-05	1.650	1.140	.140	.093	1.187	.430	.072
	-06	1.650	1.140	.165	.062	1.187	.430	.072
	-07	1.780	1.250	.165	.094	1.187	.430	.072
	-10	1.440	1.000	.140	.075	.960	.200	.100
	-11	1.312	.762	.140	.062	.960	.200	.100
	-15	1.780	1.250	.140	.046	1.187	.430	.072
	-16	2.070	1.560	.122	.062	1.187	.430	.072
	-17	1.650	1.140	.140	.046	1.187	.430	.072
	-18	1.563	1.050	.140	.140	1.187	.430	.072
	-23	1.593	1.100	.156	.062	1.187	.430	.072
	-24	1.700	1.187	.156	.062	1.187	.430	.072
	-29	1.650	1.065	.140	.046	1.187	.430	.072
	-30	1.250	.700	.140	.062	.960	.200	.100
	-31	1.375	.825	.140	.062	.960	.200	.100
	-59 Leadless	1.650	1.140	.165		1.187		
	-112	1.780	1.248	.165	.063	1.185	.429	.073
	-113	1.563	1.051	.165	.079	1.185	.429	.073
	-127	1.307	.819	.165	.063	.909	.236	.061
	-129	1.654	1.063	.138	.059	1.181	.433	.071
	-135	1.650	1.142	.165	.142	1.187	.429	.072

3 LEAD TO-3									
PART NUMBER SUFFIX	DIMENSIONS								
	"A"	"B"	"C"	"D"	"E"	"F"	"G"	"H"	"I"
-92	1.650	1.140	.140	.093	1.187	.430	.400	.155	.718

4 LEAD TO-3								
PART NUMBER SUFFIX	DIMENSIONS							
	"A"	"B"	"C"	"D"	"E"	"F"	"G"	"H"
-86	1.560	1.050	.156	.080	1.170	.470	.72°	
-87	1.563	1.050	.156	.063	1.187	.470	.72°	

8 LEAD TO-3							
PART NUMBER SUFFIX	DIMENSIONS						
	"A"	"B"	"C"	"D"	"E"	"F"	"G"
-88	1.655	1.187	.156	.060	1.187	40°	.500

10 LEAD TO-3								
PART NUMBER SUFFIX	DIMENSIONS							
	"A"	"B"	"C"	"D"	"E"	"F"	"G"	"H"
-91	1.650	1.140	.165	.040	1.187	.593	.500	32.7°

3 LEAD TO-66								
PART NUMBER SUFFIX	DIMENSIONS							
	"A"	"B"	"C"	"D"	"E"	"F"	"G"	"H"
-85	1.275	.750	.156	.100	.960	.200	.100	.200

9 LEAD TO-66								
PART NUMBER SUFFIX	DIMENSIONS							
	"A"	"B"	"C"	"D"	"E"	"F"	"G"	"H"
-83	1.440	1.000	.140	.055	.960	.480	.325	36°

POWER MODULE				
PART NUMBER SUFFIX	DIMENSIONS			
	"A"	"B"	"C"	"D"
-130	1.600	.480	.165	1.197

# SIL PAD Configurations

## Metric Measurements

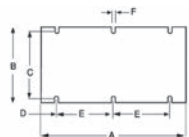
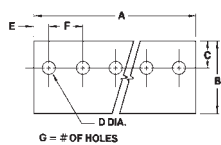
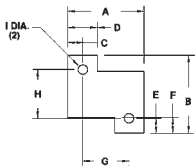
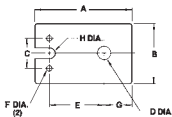
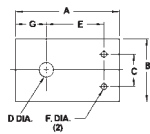
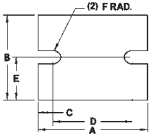
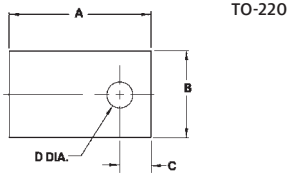
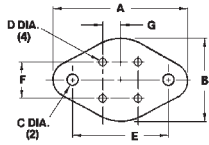

4 LEAD TO-66	PART NUMBER SUFFIX	DIMENSIONS						
		"A"	"B"	"C"	"D"	"E"	"F"	"G"
	-84	33.32	19.35	3.56	1.57	24.38	5.08	2.54

PLASTIC POWER	PART NUMBER SUFFIX	DIMENSIONS				PLASTIC POWER	PART NUMBER SUFFIX	DIMENSIONS			
		"A"	"B"	"C"	"D"			"A"	"B"	"C"	"D"
Various (Clip Mount)	-35	18.03	12.70	4.06	3.58	Various	-104	25.40	19.05	7.62	3.56
	-43	19.05	12.70	Various	-107		20.57	23.11	4.32	3.73	
	TO-126	-50	11.10	7.92	3.56		2.36	Various	-110	24.99	19.99
Various	-51	17.45	14.27	5.54	3.18	Various	-114	21.01	24.00	5.00	3.81
Various	-52	21.72	16.00	5.84	2.36	Various	-116	21.72	16.00	5.79	3.10
TO-220	-54	19.05	12.70	4.75	3.73	Various	-117	21.01	18.01	6.50	3.20
TO-202	-55	15.49	14.22	6.22	3.18	Various	-118	19.00	14.00	5.51	3.20
Various	-56	21.72	14.27	5.54	3.18	Various	-119	11.10	7.90	3.61	2.79
TO-220	-58	19.05	12.70	4.75	3.18	Various	-120	18.49	11.99	3.99	2.49
TO-126	-60	11.10	7.92	3.56	3.10	TO-3P	-122	28.96	20.57	9.02	3.73
Various	-61	19.05	10.41	5.72	3.96	Various	-126	24.00	19.00	6.50	4.11
TO-220	-62	19.05	15.24	6.10	3.81	Various	-128	24.99	42.01	8.00	3.99
Various	-63	19.05	15.24	6.10	2.92	Various	-131	18.01	13.00	4.50	3.10
Various	-64	12.70	9.78	4.32	3.05	Various	-132	11.99	8.00	3.99	3.20
TO-218	-68	28.58	15.88	5.08	3.68	Various	-133	22.00	18.01	6.50	3.20
Various	-70	35.81	20.57	9.02	3.73	Various	-134	24.00	18.01	5.79	3.20
Various	-90	21.84	18.80	5.08	4.06	Various	-136	31.75	25.40		
Various	-102	22.00	16.51	5.51	3.61	Various	-137	31.75	25.40	6.55	3.23
Various	-103	19.05	20.32	3.81	4.06	Various	-138	31.75	25.40	6.55	3.76

POWER MODULE	NUMBER SUFFIX	DIMENSIONS					
		"A"	"B"	"C"	"D"	"E"	"F"
	-67	38.10	22.86	3.81	30.48	11.43	1.90
	-101	63.50	50.80	8.74	46.02	25.40	3.96

PLASTIC POWER	PART NUMBER SUFFIX	DIMENSIONS						
		"A"	"B"	"C"	"D"	"E"	"F"	"G"
	-57	23.11	12.70	5.08	3.18	14.73	1.17	6.73
	-89	24.97	19.05	10.97	3.96	16.89	2.57	5.51

PLASTIC POWER	PART NUMBER SUFFIX	DIMENSIONS							
		"A"	"B"	"C"	"D"	"E"	"F"	"G"	"H"
	-66	25.40	12.70	5.08	3.58	15.90	1.17	5.56	0.81

POWER RESISTORS	PART NUMBER SUFFIX	DIMENSIONS								
		"A"	"B"	"C"	"D"	"E"	"F"	"G"	"H"	"I"
RH-25	-94	30.15	30.61	5.94	11.91	5.38	3.96	18.26	19.84	3.56
RH-50	-95	53.16	32.13	6.73	13.46	5.33	6.48	39.70	21.46	3.56
RH-5	-96	18.42	19.58	3.56	7.11	3.56	3.96	11.30	12.47	2.36
RH-10	-97	20.45	22.61	3.23	6.35	3.30	4.83	14.00	16.00	3.07
RH-25	-98	29.21	29.97	5.87	10.80	4.83	6.86	17.48	20.32	3.73
RH-50	-99	49.91	31.39	5.03	10.26	3.35	6.68	39.85	24.69	3.30

TO-220 MULTIPLES	PART NUMBER SUFFIX	DIMENSIONS							# OF HOLES
		"A"	"B"	"C"	"D"	"E"	"F"		
2 Parts	-34	25.40	19.05	4.75	3.18	6.35	12.70	2	
3 Parts	-36	38.10	19.05	4.75	3.18	6.35	12.70	3	
	-37	50.80	19.05	4.75	3.18	6.35	12.70	4	
	-38	63.50	19.05	4.75	3.18	6.35	12.70	5	
	-39	76.20	19.05	4.75	3.18	6.35	12.70	6	
	-40	88.90	19.05	4.75	3.18	6.35	12.70	7	
	-41	101.60	19.05	4.75	3.18	6.35	12.70	8	

POWER MODULE	PART NUMBER SUFFIX	DIMENSIONS					
		"A"	"B"	"C"	"D"	"E"	"F"
	-108	116.84	60.96	53.97	12.70	45.72	3.18
	-140	116.8	61.00	53.30	12.70	45.70	3.80
	-141	57.90	61.00	53.40	12.40	16.50	3.80
	-142	57.91	36.83	32.26	12.45	16.50	3.30

# SIL PAD Configurations

## Metric Measurements

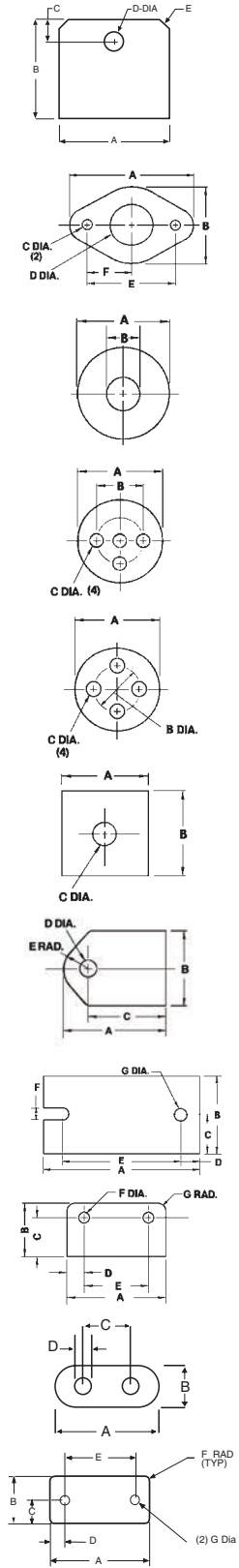

MULTIWATT	PART NUMBER SUFFIX	DIMENSIONS				
		"A"	"B"	"C"	"D"	"E"
	-124	22.15	20.07	4.06	3.76	3.0 x 45°
	-125	22.00	19.99	3.99	3.91	2.0 x 45°

MULTI- LEAD TO-66	PART NUMBER SUFFIX	DIMENSIONS					
		"A"	"B"	"C"	"D"	"E"	"F"
	-93	34.29	20.32	3.56	10.16	24.38	12.19

DIODE WASHER	PART NUMBER SUFFIX	DIMENSIONS		DIODE WASHER	PART NUMBER SUFFIX	DIMENSIONS	
		"A"	"B"			"A"	"B"
Various	-19	12.95	3.56	Various	-75	9.14	6.60
DO-4	-20	12.95	5.08	Various	-76	19.05	3.18
DO-5	-21	20.32	6.60	Various	-77	20.32	4.83
DO-4 (oversized)	-22	15.88	5.08	DO-8	-78	22.23	7.95
DO-5 (oversized)	-25	25.40	6.60	Various	-79	29.97	13.08
Various	-26	20.62	3.68	Various	-80	31.75	9.65
Various	-27	20.62	2.92	Various	-81	38.10	5.08
Various	-28	25.40	3.56	Various	-82	13.00	4.09
Various	-32	38.10	12.70		-111	15.01	5.51

TO-36	PART NUMBER SUFFIX	DIMENSIONS		
		"A"	"B"	"C"
	-08	27.00	17.53	4.83

SMALL POWER DEVICES	PART NUMBER SUFFIX	DIMENSIONS		
		"A"	"B"	"C"
TO-5, 3 Holes	-09	9.14	5.08	1.02
TO-18, 3 Holes	-12	6.35	2.54	0.91
TO-18, 4 Holes	-13	6.35	2.54	0.91
TO-5, 4 Holes	-33	9.14	5.08	1.02
TO-5, 3 Holes	-44	9.91	5.08	1.02
TO-5, 4 Holes	-45	9.91	5.08	1.02

RECTIFIER	PART NUMBER SUFFIX	DIMENSIONS		
		"A"	"B"	"C"
	-46	31.75	31.75	5.08
	-47	28.58	28.58	3.56
	-48	25.40	25.40	4.75

TIP PACKAGES	PART NUMBER SUFFIX	DIMENSIONS				
		"A"	"B"	"C"	"D"	"E"
Clip Mount	-42	24.99	19.99	5.21		
TIP-36 Plastic Tip	-53	21.97	16.51	16.51	3.56	5.21
TO-3P	-65	32.00	19.99	24.99	3.61	5.21
Plastic Clip	-73	24.99	19.99	17.98	3.61	5.21

POWER MODULE	PART NUMBER SUFFIX	DIMENSIONS						
		"A"	"B"	"C"	"D"	"E"	"F"	"G"
	-100	63.75	32.00	16.00	7.75	48.26	5.21	5.21
	-123	41.00	27.99	14.00	3.99	30.99	3.00	3.00

SIP PACKAGE	PART NUMBER SUFFIX	DIMENSIONS						
		"A"	"B"	"C"	"D"	"E"	"F"	"G"
	-105	36.83	21.29	15.54	6.22	24.38	4.32	3.05

POWER MODULE	PART NUMBER SUFFIX	DIMENSIONS			
		"A"	"B"	"C"	"D"
	-115	11.99	5.00	4.90	0.79

POWER MODULE	PART NUMBER SUFFIX	DIMENSIONS						
		"A"	"B"	"C"	"D"	"E"	"F"	"G"
	-109	34.29	16.31	8.15	4.95	24.38	1.52	3.18



# SIL PAD Configurations

## Metric Measurements

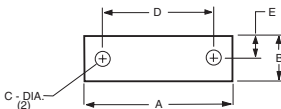
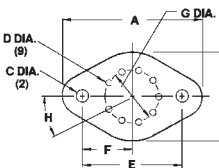
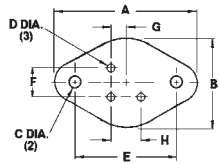
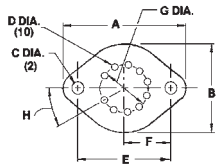
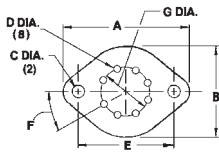
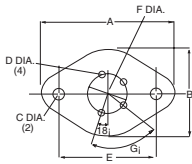
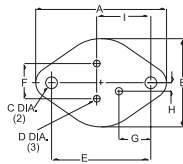
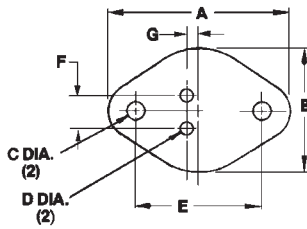

TO-3 STYLE	PART NUMBER SUFFIX	DIMENSIONS						
		"A"	"B"	"C"	"D"	"E"	"F"	"G"
	-02	45.21	31.75	3.56	2.36	30.15	10.92	1.83
	-03	39.70	26.67	3.56	2.03	30.15	10.92	1.83
	-04	41.91	28.96	3.10	1.57	30.15	10.92	1.83
	-05	41.91	28.96	3.56	2.36	30.15	10.92	1.83
	-06	41.91	28.96	4.19	1.57	30.15	10.92	1.83
	-07	45.21	31.75	4.19	2.39	30.15	10.92	1.83
	-10	36.58	25.40	3.56	1.90	24.38	5.08	2.54
	-11	33.32	19.35	3.56	1.57	24.38	5.08	2.54
	-15	45.21	31.75	3.56	1.17	30.15	10.92	1.83
	-16	52.58	39.62	3.10	1.57	30.15	10.92	1.83
	-17	41.91	28.96	3.56	1.17	30.15	10.92	1.83
	-18	39.70	26.67	3.56	3.56	30.15	10.92	1.83
	-23	40.46	27.94	3.96	1.57	30.15	10.92	1.83
	-24	43.18	30.15	3.96	1.57	30.15	10.92	1.83
	-29	41.91	27.05	3.56	1.17	30.15	10.92	1.83
	-30	31.75	17.78	3.56	1.57	24.38	5.08	2.54
	-31	34.92	20.96	3.56	1.57	24.38	5.08	2.54
	-59 Leadless	41.91	28.96	4.19		30.15		
	-112	45.21	31.70	4.19	1.60	30.10	10.90	1.85
	-113	39.70	26.70	4.19	2.01	30.10	10.90	1.85
	-127	33.20	20.80	4.19	1.60	23.09	5.99	1.55
	-129	42.01	27.00	3.51	1.50	30.00	11.00	1.80
	-135	41.91	29.01	4.19	3.61	30.15	10.90	1.83

3 LEAD TO-3	PART NUMBER SUFFIX	DIMENSIONS								
		"A"	"B"	"C"	"D"	"E"	"F"	"G"	"H"	"I"
	-92	41.91	28.96	3.56	2.36	30.15	10.92	10.16	3.94	18.24

4 LEAD TO-3	PART NUMBER SUFFIX	DIMENSIONS							
		"A"	"B"	"C"	"D"	"E"	"F"	"G"	"H"
	-86	39.62	26.67	3.96	2.03	29.72	11.94	72°	
	-87	39.70	26.67	3.96	1.60	30.15	11.94	72°	

8 LEAD TO-3	PART NUMBER SUFFIX	DIMENSIONS						
		"A"	"B"	"C"	"D"	"E"	"F"	"G"
	-88	42.04	30.15	3.96	1.52	30.15	40°	12.70

10 LEAD TO-3	PART NUMBER SUFFIX	DIMENSIONS							
		"A"	"B"	"C"	"D"	"E"	"F"	"G"	"H"
	-91	41.91	28.96	4.19	1.02	30.15	15.06	12.70	32.7°

3 LEAD TO-66	PART NUMBER SUFFIX	DIMENSIONS							
		"A"	"B"	"C"	"D"	"E"	"F"	"G"	"H"
	-85	32.38	19.05	3.96	2.54	24.38	5.08	2.54	5.08

9 LEAD TO-66	PART NUMBER SUFFIX	DIMENSIONS							
		"A"	"B"	"C"	"D"	"E"	"F"	"G"	"H"
	-83	36.58	25.40	3.56	1.40	24.38	12.19	8.26	36°

POWER MODULE	PART NUMBER SUFFIX	DIMENSIONS				
		"A"	"B"	"C"	"D"	"E"
	-130	40.64	12.19	4.19	30.40	6.10

# HI-FLOW 225 Configurations

## Imperial Measurements

### HI-FLOW 225UT/565UT Tab Configurations

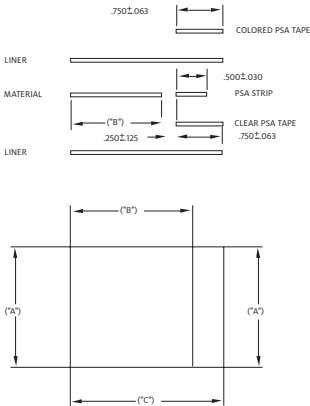

PART NUMBER SUFFIX	DIMENSIONS (± .015)			MIN. PCS./ROLL
	"A"	"B"	"C"	
-150	1.650	1.650	2.650	3,000
-151	1.500	1.500	2.500	5,000
-152	1.375	1.375	2.375	5,000
-153	1.250	1.250	2.250	5,000
-154	1.000	1.000	2.000	7,500
-155	.700	.700	1.700	10,000
-156	.500	.500	1.500	15,000

# HI-FLOW 225 Configurations

## Metric Measurements

### HI-FLOW 225UT/565UT Tab Configurations

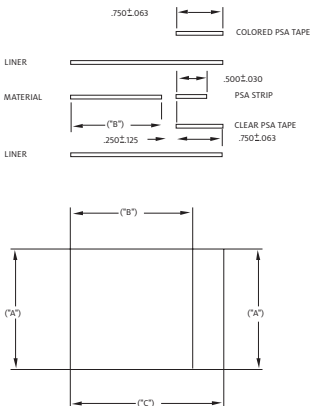

PART NUMBER SUFFIX	DIMENSIONS (± .015)			MIN. PCS./ROLL
	"A"	"B"	"C"	
-150	41.91	41.91	67.31	3,000
-151	38.10	38.10	63.50	5,000
-152	34.93	34.93	60.33	5,000
-153	31.75	31.75	57.15	5,000
-154	25.40	25.40	50.80	7,500
-155	17.78	17.78	43.18	10,000
-156	12.70	12.70	38.10	15,000

# Solutions for Surface Mount Applications

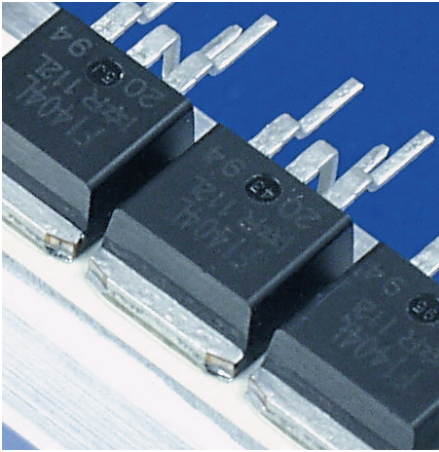

## HI-FLOW

The HI-FLOW family of phase change materials offers an easy-to-apply thermal interface for many surface mount packages. At the phase change temperature, HI-FLOW materials change from a solid and flow with minimal applied pressure. This characteristic optimizes heat transfer by maximizing wet-out of the interface. HI-FLOW is commonly used to replace messy thermal grease.

BERGQUIST phase change materials are specially compounded to prevent pump-out of the interface area, which is often associated with thermal grease. Typical applications for HI-FLOW materials include:

- High performance CPUs and integrated circuits
- DC/DC converters
- Power modules

HI-FLOW materials are manufactured with or without film or foil carriers. Custom shapes and sizes for non-standard applications are also available.

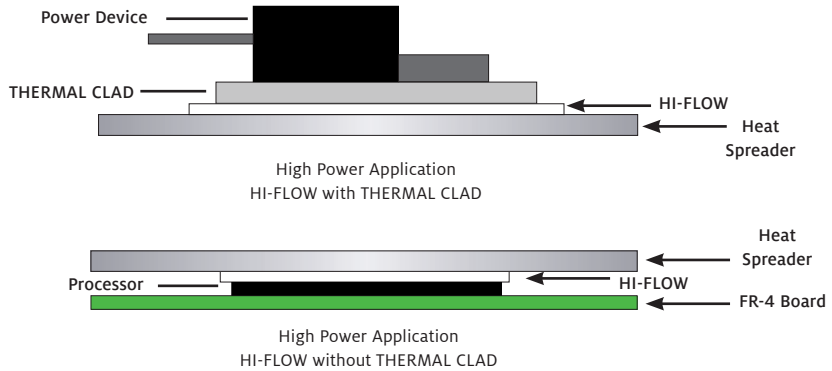
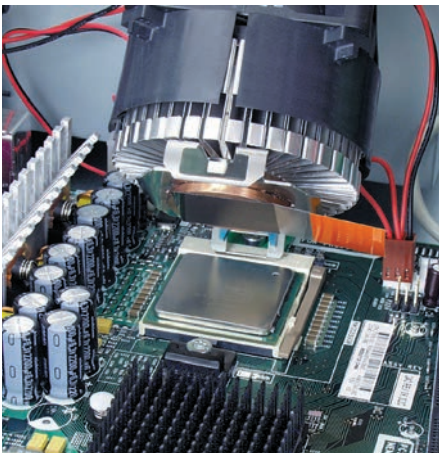

## SIL PAD

SIL PAD sets a benchmark in thermal interface materials. The SIL PAD family of materials is thermally conductive and electrically insulating. Available in custom shapes, sheets, and rolls, SIL PAD materials come in a variety of thicknesses and are frequently used in SMT applications such as:

- Interface between thermal vias in a PCB, and a heat sink or casting
- Heat sink interface to many surface mount packages

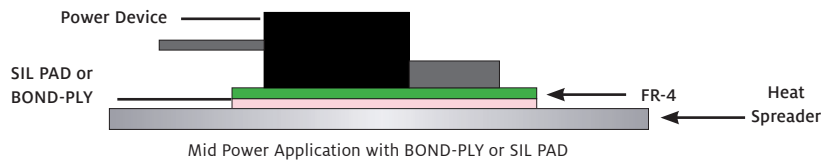
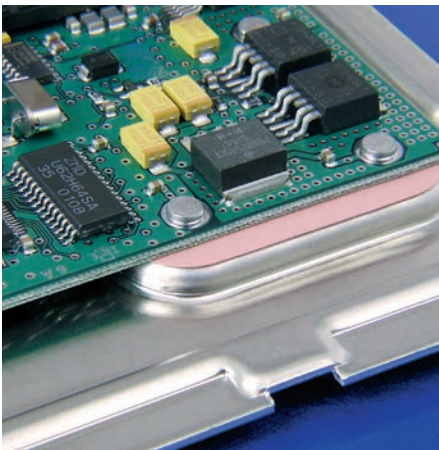

## Where Thermal Solutions Come Together

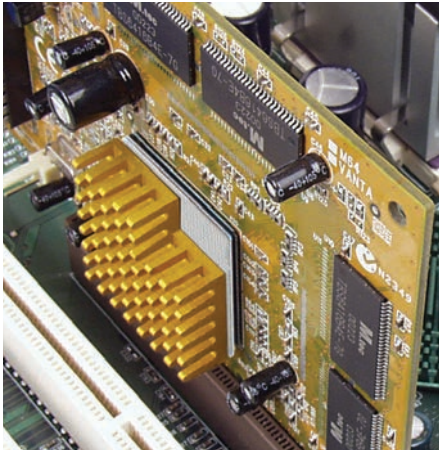

### BOND-PLY and LIQUI-BOND

The BOND-PLY family of materials is thermally conductive and electrically isolating. BOND-PLY is available in a pressure sensitive adhesive or laminating format. BOND-PLY provides for the mechanical decoupling of bonded materials with mismatched thermal coefficients of expansion. LIQUI-BOND is a high thermal performance liquid silicone adhesive that cures to a solid bonding elastomer.

Typical applications include:

- Bonding bus bars in a variety of electronic modules and sub-assemblies
- Attaching a metal-based component to a heat sink
- Bonding a heat sink to a variety of ASIC, graphic chip and CPU packages
- Bonding flexible circuits to a rigid heat spreader or thermal plane
- Assembly tapes for BGA heat spreader
- Attaching PCB assemblies to housings

### GAP PAD and Gap Filler

GAP PAD and Gap Filler product families are highly conformable, thermally conductive materials in pad or liquid dispensable format. Varying degrees of thermal conductivity and compression deflection characteristics are available.

Typical applications include:

- On top of a semiconductor package such as a QFP or BGA. Often times, several packages with varying heights can use a common heat sink when using GAP PAD.
- Between a PCB or substrate and a chassis, frame, or other heat spreader
- Areas where heat needs to be transferred to any type of heat spreader
- For interfacing pressure sensitive devices
- Filling various gaps between heat-generating devices and heat sinks or housings

GAP PADS are available in thickness of 0.010 in. to 0.250 in., and in custom shapes, with or without adhesive. Gap Fillers are available in cartridge or kit form.

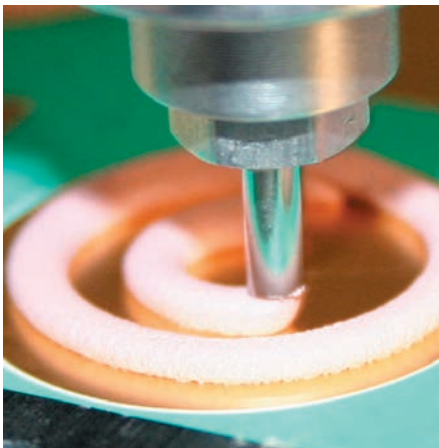
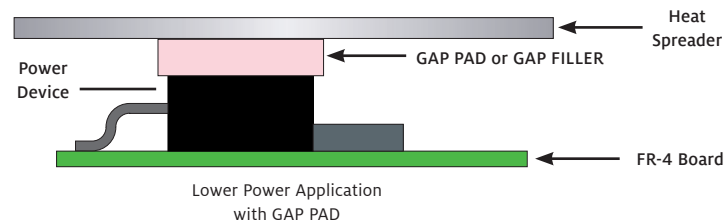
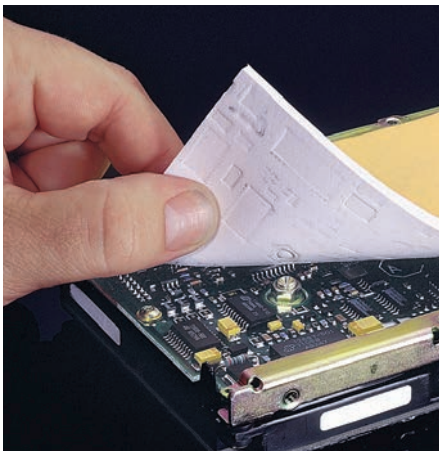

### Top Efficiency In Thermal Materials For Today's Changing Technology.

Contact Henkel for additional information regarding our thermal solutions. We are constantly innovating to offer you the greatest selection of options and flexibility to meet today's changing technology.

## Ordering Information

### Ordering Procedure:

The last 2 or 3 digits define the part number selected. The “footprint” and dimensions are shown on pages 91-97.

### Special Shapes:

For applications requiring non-standard or custom SIL PAD configurations, contact your Henkel Sales Representative. We produce thousands of custom die shapes and designs.

### Tolerances:

Typical converting tolerances are held on length (L), width (W), hole diameter and hole location for most materials as noted below:

TYPICAL SIL PAD / HI-FLOW TOLERANCES			
Part (1) Dimension	Length and Width Tolerance	Rule Defined Features (2)	Hole Location and Diameter
<6 in.	± 0.010 in. (0.25 mm)	± 0.010 in. (0.25 mm)	± 0.005 in. (0.13 mm)
6 in. - 12 in.	± 0.015 in. (0.38 mm)	± 0.015 in. (0.38 mm)	± 0.010 in. (0.25 mm)
>12 in.	± 0.020 in. (0.51 mm)	± 0.020 in. (0.51 mm)	± 0.020 in. (0.51 mm)
TYPICAL GAP PAD TOLERANCES (3)			
Material Thickness	Length and Width Tolerance	Hole Location and Diameter	
10 mil	± 0.015 in. (0.38 mm)	± 0.015 in. (0.38 mm)	
15 mil	± 0.015 in. (0.38 mm)	± 0.015 in. (0.38 mm)	
20 mil	± 0.020 in. (0.51 mm)	± 0.020 in. (0.51 mm)	
30 mil	± 0.030 in. (0.76 mm)	± 0.030 in. (0.76 mm)	
40 mil	± 0.035 in. (0.89 mm)	± 0.035 in. (0.89 mm)	
50 mil	± 0.040 in. (1.02 mm)	± 0.040 in. (1.02 mm)	
60 mil	± 0.050 in. (1.27 mm)	± 0.050 in. (1.27 mm)	
70 mil	± 0.050 in. (1.27 mm)	± 0.050 in. (1.27 mm)	
80 mil	± 0.050 in. (1.27 mm)	± 0.050 in. (1.27 mm)	
100 mil	± 0.060 in. (1.52 mm)	± 0.060 in. (1.52 mm)	
125 mil	± 0.075 in. (1.91 mm)	± 0.075 in. (1.91 mm)	
140 mil	± 0.100 in. (2.54 mm)	± 0.100 in. (2.54 mm)	
160 mil	± 0.100 in. (2.54 mm)	± 0.100 in. (2.54 mm)	
200 mil	± 0.125 in. (3.17 mm)	± 0.125 in. (3.17 mm)	
225 mil	± 0.160 in. (4.06 mm)	± 0.160 in. (4.06 mm)	
250 mil	± 0.160 in. (4.06 mm)	± 0.160 in. (4.06 mm)	

1) Material thicknesses: <6 in. (152.4mm), 6-12 in. (152.4-304.8mm), >12 in. (304.8mm).  
 2) Rule defined by geometry can be notches, internal shapes not created by a punch or cutouts that are created by a rule and not a punch.  
 3) GAP PAD VO materials have a SIL PAD Side / Cutline tolerance of parts on the liner to within ± 0.020 in. (0.51mm) typically, GAP PAD may deform to the standard tolerances when handled or removed from the liner.

Note: Dependent upon material and application requirements, tighter tolerances may be feasible and available. Please contact Henkel Sales for these requests and additional information regarding tolerances.

### Typical Configuration Tolerances:

- Roll width: ±0.06 in. (1.6 mm) for standard widths (2 in., 4 in., 6 in., etc.)
- SIL PAD sheet: -0.06 in. / +0.25 in. (-1.6 mm / +6.4 mm)
- GAP PAD sheet: -0.0 in. / +0.40 in. (-0.0 mm / +10.0 mm)
- Typical SIL PAD roll length: 250-foot to 300-foot
- Typical number of splices per roll: 3
- Typical butt splice: 2-sided colored tape
- Material thickness tolerances: SIL PAD ±0.001 in. (0.0254 mm)  
GAP PAD VO ±5%  
GAP PAD S-Class ±10%

Note: Tighter tolerances are available per factory review.

### Sheets:

Standard sheet size for most materials is 12 in. x 12 in., with or without adhesive as specified on the individual data sheet. When ordering sheets, please specify material type, thickness and include all dimensions. Contact Henkel Sales if other sizes are required.

Note: SIL PAD A2000 maximum sheet size is 10 in. x 12 in. GAP PAD standard sheet size is 8 in. x 16 in.

### Rolls:

SIL PAD materials are available in roll form, with or without adhesive, with the exception of SIL PAD 1750 and SIL PAD 2000. HI-FLOW materials are available in roll form. Certain GAP PAD materials are available in roll form. Please contact Henkel Sales for more information.

### Color Matching:

We identify product color as a reference product characteristic and/or specification for SIL PAD and GAP PAD products. Slight color variation is normal across lot-to-lot splicing due to the different variations in natural colorants used to achieve the desired hue and shade in these products. We continue to monitor and control incoming raw material specifications and production processes to ensure the highest possible consistency of quality and product performance. If you have any questions regarding color matching, please contact Henkel Product Management.



## Ordering Information

### Adhesives:

BERGQUIST adhesives include:

SILICONE: (AC) - Unloaded  
(ACA) - Unloaded, Low Tack  
(TAC) - Loaded (Thermally Enhanced)

ACRYLIC: (AAC) - Unloaded  
(TAAC) - Thermally Loaded  
(EAAC) - Thermally Enhanced

THICKNESS: 0.0005 in. - 0.001 in., (12-25µm)  
(adhesive only)

Note: For non-symmetrical parts, please indicate on print which side the adhesive is on.

### Peel Strength: See data below.

POL = Peel-Off Liner (force per unit width of the liner to the adhesive)

QS = Quick Stick (simulated force per unit width of the adhesive to the heat sink)

g/in. = Grams per inch

TYPICAL ADHESIVE PROPERTIES		
ADHESIVE	POL	QS
Silicone AC	50-150 g/in.	50-150 g/in.
Silicone ACA	5-70 g/in.	5-150 g/in.
Silicone TAC	50-150 g/in.	50-150 g/in.
Acrylic AAC	5-70 g/in.	100-800 g/in.
Acrylic TAAC	5-70 g/in.	100-400 g/in.
Acrylic EAAC	5-60 g/in.	100-200 g/in.

Note: These values are typical after the material has aged for 2-3 weeks and are significantly different immediately after coating. Upon completion of coating, QS is 250-500 g/in. and POL is 3-20 g/in. for all silicone adhesives.

### Shelf Life:

Silicone Adhesives: Six (6) months from date of manufacture when stored in original packaging at 70°F (21°C) and 50% relative humidity.

Acrylic Adhesives: One (1) year from date of manufacture when stored in original packaging at 70°F (21°C) and 50% relative humidity.

Peel adhesion data is available upon request. Please contact Henkel Sales for more information.

### PSA Characteristics:

Standard pressure sensitive adhesive coated on one side of a SIL PAD will increase the thermal resistance (per ASTM D5470) by 0.2°C-in.<sup>2</sup>/W. Standard pressure sensitive adhesive on two sides increases the thermal impedance by 0.4°C-in.<sup>2</sup>/W.

Thermally conductive pressure sensitive adhesive on one side increases the thermal resistance by 0.05°C-in.<sup>2</sup>/W and on two sides by 0.1°C-in.<sup>2</sup>/W.

The effect of an adhesive layer on the thermal impedance in an application will vary. In low-pressure applications, the pressure sensitive adhesive will wet-out the interface easier and eliminate the interfacial thermal resistance.

### UL Recognition:

For information regarding the UL (Underwriters Laboratories, Inc.) recognition status of Henkel (BERGQUIST) SIL PAD, GAP PAD and HI-FLOW materials, the UL web site provides the most current information.

Using the URL: <http://www.ul.com>, select "Online Certification Directory." You may then enter one of the following file numbers for the applicable BERGQUIST file:

QMFZ2.E59150: Plastics – Component. This category includes all SIL PAD, GAP PAD and HI-FLOW materials.

QOQW2.E81718: Polymeric Adhesive Systems, Electrical Equipment – Component. This category includes BOND-PLY adhesive only.

In each group there is a "Guide Information" section which gives a detailed description of the categories listed and all recognized materials will be listed with supporting data.

August 2017

All statements, technical information and recommendations herein are based on tests we believe to be reliable, and THE FOLLOWING IS MADE IN LIEU OF ALL WARRANTIES, EXPRESSED OR IMPLIED, INCLUDING THE IMPLIED WARRANTIES OF MARKETABILITY AND FITNESS FOR PURPOSE. Sellers' and manufacturers' only obligation shall be to replace such quantity of the product proved to be defective. Before using, user shall determine the suitability of the product for its intended use, and the user assumes all risks and liability whatsoever in connection there-with. NEITHER SELLER NOR MANUFACTURER SHALL BE LIABLE EITHER IN TORT OR IN CONTRACT FOR ANY LOSS OR DAMAGE, DIRECT, INCIDENTAL, OR CONSEQUENTIAL, INCLUDING LOSS OF PROFITS OR REVENUE ARISING OUT OF THE USE OR THE INABILITY TO USE A PRODUCT. No statement, purchase order or recommendations by seller or purchaser not contained herein shall have any force or effect unless in an agreement signed by the officers of the seller and manufacturer.

© Copyright 2017, Henkel Corporation. All rights reserved.





**AMERICAS****HEADQUARTERS:****UNITED STATES**

Henkel Electronic Materials, LLC  
14000 Jamboree Road  
Irvine, CA 92606  
USA  
Tel: +1.888.943.6535  
Fax: +1.714.368.2265

Henkel Electronic Materials, LLC  
20021 Susana Road  
Rancho Dominguez, CA 90221  
USA  
Tel: +1.310.764.4600  
Fax: +1.310.605.2274

Henkel Electronic Materials, LLC  
18930 W. 78th Street  
Chanhassen, MN 55317  
USA  
Tel: +1.952.835.2322  
Tel: +1.800.347.4572  
Fax: +1.952.835.0430

**BRAZIL**

Henkel Brazil  
Av. Prof. Vernon Kriebler, 91  
06690-070 Itapevi,  
Sao Paulo, Brazil  
Tel: +55.11.3205.7001  
Fax: +55.11.3205.7100

**ASIA-PACIFIC****CHINA**

No. 332 Meigui South Road  
WaiGaoQiao Free Trade Zone, Pu Dong  
Shanghai 200131, P.R. China  
Tel: +86.21.3898.4800  
Fax: +86.21.5048.4169

**JAPAN**

Henkel Japan Ltd.  
27-7, Shin Isogo-cho  
Isogo-ku Yokohama, 235-0017  
Japan  
Tel: +81.45.286.0161  
Email: jp.ae-csdesk@henkel.com

**KOREA**

Henkel Technologies (Korea) Ltd.  
6th Floor  
Dae Ryung Techno Town II  
33-33 Gasan-dong,  
Geumcheon-gu, Seoul 153-771  
Korea  
Tel: +82.2.6675.8000  
Fax: +82.2.6675.8191

**SINGAPORE**

Henkel Singapore Pte Ltd.  
401, Commonwealth Drive  
#03-01/02 Haw Par Technocentre,  
Singapore 149598  
Tel: +65.6266.0100  
Fax: +65.6472.8738 / +65.6266.1161

**EUROPE****BELGIUM**

Henkel Electronics Materials (Belgium)  
N.V. Nijverheidsstraat 7  
B-2260 Westerlo  
Belgium  
Tel: +32.1457.5611  
Fax: +32.1458.5530

**UNITED KINGDOM**

Henkel Ltd.  
Adhesives Limited Technologies House  
Wood Lane End  
Hemel Hempstead  
Hertfordshire HP2 4RQ  
Tel: +44.1442.278000  
Fax: +44.1442.278071

Across the Board,  Around the Globe.

[henkel-adhesives.com/thermal](http://henkel-adhesives.com/thermal)